

Vcolor 229/249 series

Electronic controllers with 5" or 7" TFT graphic display for cabinets, counters and temperature- and humidity-controlled cold rooms



WARNING
Make sure you read and fully understand the user manual before using this device.
Non-observance of these instructions will result in death or serious injury.



IMPORTANT INFORMATION	6
IMPORTANT SAFETY INFORMATION	7
SAFETY INFORMATION RELATING TO THE PRODUCT	8
1. INTRODUCTION	9
1.1 Description	9
1.2 Available models	9
1.3 Features	9
1.4 Accessories	10
2. TECHNICAL DATA	11
2.1 Technical specifications.....	11
2.1.1 User interface.....	11
2.1.2 Base board	11
2.2 I/O specifications	12
2.2.1 Base board	12
3. MECHANICAL ASSEMBLY	13
3.1 Before you start	13
3.2 Information concerning installation and the surrounding environment	13
3.3 Front-mounting model dimensions	14
3.3.1 Vcolor 229/249 M user interface	14
3.3.2 Vcolor 229/249 L user interface	14
3.4 Panel-back mounting model dimensions.....	15
3.4.1 Vcolor 229/249 M user interface	15
3.4.2 Vcolor 229/249 L user interface	15
3.5 Base board dimensions	16
3.6 Vcolor 229/249 installation.....	17
3.6.1 Wall mounting	17
3.6.2 Panel-back mounting.....	18
3.7 Base power board installation.....	20
3.8 Minimum installation distances.....	20
3.8.1 Vcolor 229/249 M/L user interface	20
3.8.2 Base board	20
4. ELECTRICAL CONNECTIONS	21
4.1 Wiring best practices	21
4.1.1 Wiring guidelines.....	21
4.1.2 Guidelines for screw terminals	22
4.1.3 Permitted cable lengths.....	22
4.2 Wiring diagram	22
4.2.1 Vcolor 229/249 M user interface	22
4.2.2 Vcolor 229/249 L user interface	23



4.2.3 Vcolor 229 M/L base board	24
4.2.4 Vcolor 249 M/L base board	25
5. USER INTERFACE	27
5.1 Interface	27
5.2 Icons.....	27
5.3 Touch keys	28
5.4 Using the controller	28
5.4.1 Controller ON/OFF	28
5.4.2 Screensaver	29
5.4.3 Accessing and using the menu.....	29
5.5 Data Log.....	30
5.6 Door lock/unlock	31
5.7 General settings	32
5.7.1 Change Date and Time	32
5.7.2 Change language	33
5.7.3 Assign a name to the unit.....	33
5.7.4 Delete favourite foods to store.....	34
5.7.5 Welcome page	34
5.8 Change evaporator fan speed	34
5.9 Energy saving / Eco mode	35
5.10 Cold room light	36
5.11 Manual defrost.....	36
5.12 Favourite foods to store (pre-set and favourites)	38
5.12.1 OEM group	38
5.12.2 USER group.....	38
5.13 Alarms	39
5.13.1 Active alarm list.....	40
5.13.2 Delete alarm log	41
5.14 Special cycles.....	41
5.14.1 Cooling.....	42
5.14.2 Continuous cycle.....	43
5.14.3 Sanitising	44
5.14.4 Thawing.....	45
5.15 Temperature chart	46
5.16 Service	47
5.16.1 Login	47
5.16.2 I/O status.....	47
5.16.3 Battery status.....	47
5.17 Parameter management	48



CONTENTS

5.17.1	Parameter settings	48
5.17.2	Restore parameters	48
5.18	Advanced functions	49
5.18.1	Output test	49
5.18.2	Test cycle	49
5.19	Mistral humidifier management.....	51
5.19.1	Operating mode	52
5.19.2	Internal values	52
5.19.3	Counters	52
5.19.4	Information	53
6.	DEFROSTING.....	54
6.1	Introduction	54
6.1.1	Operating conditions.....	54
6.1.2	Dripping interval.....	54
6.2	Standard defrost.....	55
6.2.1	Electric heater defrost	55
6.2.2	Cycle inversion (hot gas) defrost	56
6.2.3	Defrost on compressor stoppage.....	58
7.	REGULATORS	59
7.1	Hot/cold temperature	59
7.1.1	Operation	59
7.2	Hot/Cold temperature with neutral zone	60
7.2.1	Operation	60
7.3	Humidity	60
7.3.1	Operation	61
7.4	Humidity with neutral zone.....	61
7.4.1	Operation	61
7.4.2	Humidification management	61
7.4.3	Dehumidification management.....	62
7.5	Compressor	62
7.5.1	Operating diagrams	63
7.5.2	Variable speed compressor	64
7.6	Evaporator fans.....	64
7.6.1	Regulator operation.....	64
7.6.2	Operating modes	64
7.6.3	Operation during a defrost.....	65
7.6.4	Evaporator fan operation during dripping	65
7.7	Condenser fans	65
7.7.1	Operation	65
7.8	Energy Saving / ECO	66



CONTENTS

7.8.1 Operation	66
7.9 Heaters.....	67
7.10 STEAM GENERATOR OUTPUT.....	67
7.11 HUMIDIFIER OUTPUT	67
7.11.1 Humidifier output management without probe or transducer.....	67
7.11.2 Isothermal humidifier Humidifier output management with probe or transducer.....	67
7.11.3 Adiabatic humidifier Humidifier output management with transducer.....	67
7.12 Alarm output management	67
7.13 Door frame heater management.....	67
7.14 Standby/On output management	67
7.15 Cold room light management.....	67
7.16 Door lock management	67
7.17 Water filling management	68
8. PARAMETERS	69
8.1 Table of configuration parameters	69
9. DIAGNOSTICS	79
9.1 Vcolor 229/249 M/L alarm table	79
9.2 Mistral humidifier alarm table.....	84
9.3 Inverter alarm table	85

IMPORTANT INFORMATION

Liability and residual risks

EVCO assumes no liability for any damage caused by the following (by way of example; this is not an exhaustive list):

- Installation/use for purposes other than those specified and, in particular, not adhering to the safety provisions set out by current regulations in the country in which the product is installed and/or contained in this manual;
- Use in appliances that do not guarantee sufficient protection against electric shocks, water and dust within the installation conditions created;
- Use in appliances that allow access to hazardous parts without the use of a keyed or tooled locking mechanism when accessing the instrument;
- Tampering and/or modifying the product;
- Installation/use in appliances which do not comply with current regulations in the country in which the product is installed.

The customer/manufacturer is responsible for ensuring their machine complies with these regulations.

EVCO's responsibility is limited to the correct and professional use of the product in accordance with regulations and the instructions contained in this manual and other product support documents.

To comply with EMC standards, observe all the electrical connection instructions. As it depends on the wiring configuration as well as the load and the installation type, compliance must be verified for the final machine as specified by the relevant product standard.

Disclaimer

This document is the exclusive property of EVCO. It contains a general description and/or a description of the technical specifications for the services offered by the products listed herein. This document should not be used to determine the suitability or reliability of these products in relation to specific user applications. Each user or integration specialist should conduct their own complete and appropriate risk analysis, in addition to carrying out a product evaluation and test in relation to its specific application or use. Users can send us comments and suggestions on how to improve or correct this publication.

Neither EVCO nor any of its associates or subsidiaries shall be held responsible or liable for improper use of the information contained herein.

EVCO has a policy of continuous development; therefore, EVCO reserves the right to make changes and improvements to any product described in this document without prior notice.

The images in this document and other documentation supplied with the product are provided for illustrative purposes only and may differ from the product itself.

The technical data in this manual is subject to change without prior notice.

Terms and Conditions of use

Permitted use

The device must be installed and used in accordance with the instructions provided and, in particular, hazardous live parts must not be accessible under normal conditions.

The device must be suitably protected from water and dust with regard to its application and must also only be accessible with the aid of a tool (with the exception of the front panel).

Only qualified personnel may install the product or perform technical support procedures on it.

The customer must only use the product as described in the documentation relating to that product.

Prohibited use

Any use other than those described in the "**Permitted use**" section and in the product support documentation is prohibited.

Disposal



The device must be disposed of in accordance with local regulations regarding the collection of electrical and electronic appliances.

Consider the environment



The company works towards protecting the environment, while taking account of customer requirements, technological innovations in materials and the expectations of the community to which we belong. EVCO places great importance on respecting the environment, encouraging all associates to become involved with company values and guaranteeing safe, healthy and functional working conditions and workplaces.

Please consider the environment before printing this document.

IMPORTANT SAFETY INFORMATION

Please read this document carefully before installation; study all the warnings before using the device. Only use the device in accordance with the methods described in this document. The following safety messages may be repeated several times in the document, to provide information regarding potential hazards or to attract attention to information which may be useful in explaining or clarifying a procedure.



This symbol is used to indicate a risk of electric shock.
It is a safety indication and as such, should be observed to avoid potential accidents or fatalities.



This symbol is used to indicate a risk of serious personal injury.
It is a safety indication and as such, should be observed to avoid potential accidents or fatalities.

DANGER

DANGER indicates a situation of imminent danger which, if not avoided, **will lead to death or serious injury**.

WARNING

WARNING indicates a situation of imminent danger which, if not avoided, **may lead to death or serious injury**.

CAUTION

CAUTION indicates a potentially hazardous situation which, if not avoided, **could cause minor or moderate injury**.

NOTICE

NOTICE indicates a situation not related to physical injuries but which, if not avoided, could damage the equipment.

NOTE: The maintenance, repair, installation and use of electrical equipment must only be entrusted to qualified personnel.

QUALIFIED PERSONNEL

Only suitably trained and experienced personnel capable of understanding the content of this manual and all documentation regarding the product are authorised to work on and with this equipment. Furthermore, the personnel must have completed courses in safety and must be able to recognise and prevent the implied dangers. The personnel must have suitable training, knowledge and experience at a technical level, and be capable of anticipating and detecting potential risks caused by using the product, as well as changing the settings and modifying the mechanical, electric and electronic equipment for the entire system in which the product is used. All personnel working on and with the product must be entirely familiar with the relevant standards and directives, as well as safety regulations.

SAFETY INFORMATION RELATING TO THE PRODUCT

Before carrying out any work on the equipment, read these instructions carefully, making sure you understand everything.

DANGER

RISK OF ELECTRIC SHOCK, EXPLOSION OR ELECTRIC ARC

- Only use electrically insulated measuring devices and equipment.
- Do not install the equipment while the power supply is connected.
- Cut off the power supply to all equipment, including any connected devices, before installing/uninstalling the device.
- Always use a properly calibrated Voltmeter to make sure the system is powered off.
- Do not touch the unshielded components or the terminals while they are live.
- Do not open, disassemble, repair or modify the product.
- Do not expose the equipment to liquids or chemicals.
- Before applying voltage to the equipment:
 - Make sure all protective elements, such as covers, hatches and grilles, are fitted and/or closed.
 - Check all wiring connections.

DANGER

RISK OF ELECTRIC SHOCK AND FIRE

- Do not use the device with loads greater than those indicated in the technical data section.
- Do not exceed the temperature and humidity ranges indicated in the technical data section.
- Use the required safety interlocks (fuses and/or magnetothermal switches) of a suitable size.

DANGER

RISK OF ELECTRIC SHOCK OR MALFUNCTIONING OF THE EQUIPMENT

Do not use damaged products or accessories.

WARNING

MALFUNCTIONING OF THE EQUIPMENT

- Perform the wiring carefully, in compliance with electromagnetic compatibility requirements.
- Make sure the wiring is correct for its application.
- Use shielded cables for all I/O signal and communication cables.
- Minimise the length of the connections as much as possible, to avoid winding the cables around electrically connected parts.
- The signal (digital and analogue inputs, communication and corresponding power supplies) and power cables for the device must be routed separately.
- Before applying the power supply, check all the wiring connections.
- Use the necessary safety interlocks wherever the risk of injury to personnel and/or equipment damage exists.
- Install and use this device in a cabinet of a suitable class for the intended environment, protected by a keyed locking mechanism or other suitable instruments.
- In terms of connection and the fuses used in the circuits for the power supply and output lines, observe local and national regulatory requirements relating to the nominal current and voltage for the equipment in use.
- Do not use this equipment for machine functions that are critical to safety.
- Do not disassemble, repair or modify the equipment.
- Do not connect wires to unused terminals and/or terminals marked with the text "No connection" ("N.C").

1. INTRODUCTION

1.1 DESCRIPTION

Vcolor 229/249 M/L controllers are the EVCO solution designed for the full management of LT or NT (Low temperature or Normal temperature) refrigerated cabinets and for temperature-/humidity-controlled cold rooms.

Vcolor 229/249 M/L controllers consist of:

- Base power board;
- User display interface.

The user interface consists of a colour TFT graphic display featuring capacitive touchscreen technology, available in two sizes with horizontal alignment:

- 5" touchscreen TFT display;
- 7" touchscreen TFT display.

Depending on the machine configuration, humidity management can also be integrated using standard transducers at a 4...20 mA current or, alternatively, a dedicated EVCO temperature+humidity probe (see "**1.4 Accessories**" on page 10).

The innovative **Vcolor 229/249 M/L** programmable platform allows the customer fully independent management of the following:

- Controller graphics customisation;
- Food menu management (by adding high-quality photos);
- The addition of other languages other than those made available by EVCO.

1.2 AVAILABLE MODELS

The **Vcolor 229/249 M/L** series includes 4 controllers:

- **Vcolor 229 M** - Controller for refrigerated cabinets with a 5" display and PWM output;
- **Vcolor 229 L** - Controller for refrigerated cabinets with a 7" display and PWM output;
- **Vcolor 249 M** - Controller for refrigerated cabinets with a 5" display and 0...10 V output;
- **Vcolor 249 L** - Controller for refrigerated cabinets with a 7" display and 0...10 V output;

1.3 FEATURES



The main features of the **Vcolor 229/249 M/L** series are:

- 5 analogue inputs, of which:
 - 3 analogue inputs for temperature (PTC/NTC/Pt1000);
 - 1 analogue input for humidity probe **EVHTP520**;
 - 1 analogue input for humidity probe, 4...20 mA;
- 4 volt-free digital inputs;
- 9 sealed relay outputs;
 - Digital output expansion device also available on request, for a further 4 non-sealed relay outputs;
- 1 PWM output (**Vcolor 229 M/L** only);
- 1 analogue output, 0...10 V (**Vcolor 249 M/L** only);
- 1 RS-485 MODBUS RTU serial port;
- 1 USB-A port;
- **EPoCA**-compatible;

NOTE: for further information regarding input and output specifications, please refer to paragraph "**2.1 Technical specifications**" on page 11.

1.4 ACCESSORIES

The Vcolor 229/249 M/L range is supplemented with the following accessories:

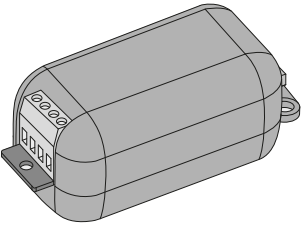
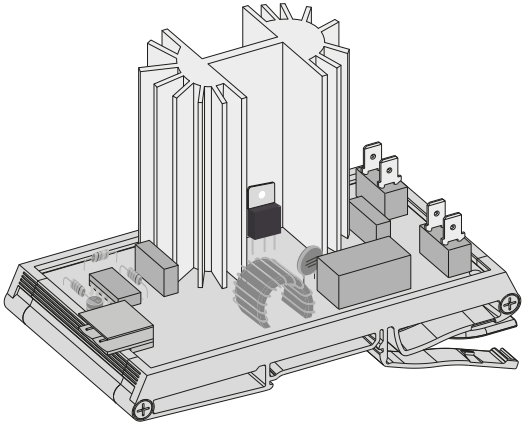
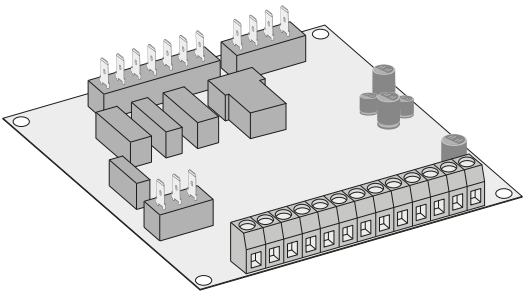
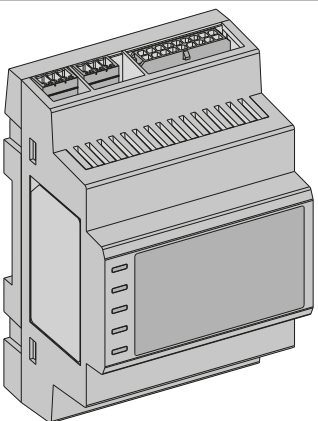
Type	P/n	Description
	---	NTC/PTC/Pt1000 temperature probes
	EVHTP520	NTC temperature/humidity probe
	EVHP523	Humidity probe 4...20 mA
	EVIF25SWX	EVlinking RS-485/Wi-Fi module
	EVDFAN1	Evaporator fan PWM module
---	CJAV55	Kit for removable terminals on the power base
	EVC20P52N9XXX10	Expansion device with 4 unsealed digital outputs
	EVC20P52N9XXX12	Expansion device with 4 sealed digital outputs
	EVPS9B	Backup module

2. TECHNICAL DATA

All the system components of **Vcolor 229/249 M/L** controllers satisfy European Community (EC) requirements for built-in equipment. They must be installed in casing or another location designated on the basis of specific environmental conditions and in order to minimise the risk of involuntary contact with hazardous voltage. Use metal casing to improve immunity to the electromagnetic fields of the **Vcolor 229/249 M/L** system. This equipment satisfies the EC requirements as indicated in the tables below.

WARNING

MALFUNCTIONING OF THE EQUIPMENT

Do not exceed any of the nominal values specified in this section.

2.1 TECHNICAL SPECIFICATIONS

2.1.1 User interface

Type	Description
The product complies with the following harmonised standards:	EN60730-1 and EN60730-2-9
Device construction:	Incorporated electronic device
Device purpose:	Operating control device
Type of action:	1
Pollution category:	2
Overvoltage category:	I
Nominal pulse voltage:	330 V
Power supply:	Vcolor 229/249 M: 12 Vdc from base board Vcolor 229/249 L: 12 Vac/dc $\pm 10\%$, 50/60 Hz (from power supply unit)
Consumption:	10 VA maximum
Ambient operating conditions:	0 ... 55 °C (32 ... 131 °F) 10 ... 90 % RH non-condensing
Transportation and storage conditions:	-25 ... 70 °C (-13 ... 158 °F) 10 ... 90 % RH non-condensing
Software class:	A
Ambient front protection:	IP65
RTC:	Built-in lithium battery
RTC drift:	≤ 60 s/month at 25 °C (77 °F)
Battery life:	> 6 months at 25 °C (77 °F)
Battery charging time:	24 h using instrument power supply

2.1.2 Base board

Type	Description
The product complies with the following harmonised standards:	EN60730-1 and EN60730-2-9
Device construction:	Incorporated electronic device
Device purpose:	Operating control device
Type of action:	1
Pollution category:	2
Overvoltage category:	II
Nominal pulse voltage:	2500 V
Power supply:	115...230 Vac, $\pm 10\%$, 50/60 Hz
Consumption:	10 VA maximum
Ambient operating conditions:	0 ... 55 °C (32 ... 131 °F) 10 ... 90 % RH non-condensing
Transportation and storage conditions:	-25 ... 70 °C (-13 ... 158 °F) 10 ... 90 % RH non-condensing
Software class:	A
Ambient front protection:	IP00

2.2 I/O SPECIFICATIONS

2.2.1 Base board

Type	Description
Digital inputs:	4 voltage-free digital inputs
Analogue inputs for temperature:	3 analogue inputs for NTC, PTC, Pt1000 probes
Analogue inputs for humidity:	2 analogue inputs for humidity probes: 1 input for probe EVHTP520 1 input for probe 4...20 mA
Low voltage (SELV) digital output:	9 low voltage digital outputs
PWM digital output:	1 PWM output (Vcolor 229 M/L only)
Analogue output 0...10 V:	1 analogue output 0... 10 V (Vcolor 249 M/L only)
Serial port:	1 RS-485 RTU SLAVE communication serial port 1 HMI user interface communication serial port

Analogue input specifications

	Default	NTC 10 k Ω at 25 °C BETA 3435	PTC KTY 81-121 990 Ω at 25 °C	Pt1000 Class B	Current 4...20 mA	RH EVHTP520
Pb1	Cold room probe	•	•	•	---	---
Pb2	Evaporator probe	•	•	•	---	---
Pb3	Not configured	•	•	•	---	---
Pb4	Humidity (EVHTP520)	---	---	---	---	•
Pb5	Humidity	---	---	---	•	---
Range	---	-50...120 °C (-58...248 °F)	-50...150 °C (-58...302 °F)	-50...110 °C (-58...230 °F)	5 ...95 % RH	5 ...95 % RH
Solution	---	0.1 °C (1 °F)		0.1 °C (1 °F)	±3 % 5...80 %, ±5 otherwise.	1 %
Input impedance	---	10 k Ω	990 Ω	---	---	---

Digital output specifications

Relay output	Default	Description	Load (at 250 Vac)	Load type
Out1	Compressor 1	SPST	16 A	Resistive
Out2	Light	SPST	8 A	Resistive
Out3	Condenser 1 fans	SPST	8 A	Resistive
Out4	Evaporator fans (maximum speed)	SPST	8 A	Resistive
Out5	Alarm	SPDT	8 A	Resistive
Out6	Defrost	SPST	16 A	Resistive
Out7	Heaters	SPST	16 A	Resistive
Out8	Door heaters	SPST	8 A	Resistive
Out9	Sanitising	SPST	8 A	Resistive

3. MECHANICAL ASSEMBLY

3.1 BEFORE YOU START

Read this manual carefully before installing the system.

In particular, the safety instructions, electrical requirements and current regulations for the machine or the process in which this device is involved must be observed. The use and application of the information contained herein requires experience in the design and programming of automated control systems. Only the user, integrator or manufacturer of the machine can be familiar with all the conditions and factors which arise during installation and configuration, operation and maintenance of the machine or the process, and as such can identify the relevant automation equipment and the corresponding interlocks and safety systems which can be used effectively and appropriately. When selecting automation and control equipment and other connected equipment and software, for a particular application, you must consider all applicable local, regional and national standards and/or regulations.

WARNING

REGULATORY INCOMPATIBILITY

Make sure all the equipment used and the systems conform to all applicable local, regional and national regulations and standards.

3.2 INFORMATION CONCERNING INSTALLATION AND THE SURROUNDING ENVIRONMENT

Before carrying out any work on the equipment, read these instructions carefully, making sure you understand everything.

DANGER

RISK OF ELECTRIC SHOCK, EXPLOSION OR ELECTRIC ARC

- Only use electrically insulated measuring devices and equipment.
- Do not install the equipment while the power supply is connected.
- Cut off the power supply to all equipment, including any connected devices, before installing/uninstalling the device.
- Always use a properly calibrated Voltmeter to make sure the system is powered off.
- Do not touch the unshielded components or the terminals while they are live.
- Do not open, disassemble, repair or modify the product.
- Do not expose the equipment to liquids or chemicals.
- Before applying voltage to the equipment:
 - Make sure all protective elements, such as covers, hatches and grilles, are fitted and/or closed.
 - Check all wiring connections.

WARNING

MALFUNCTIONING OF THE EQUIPMENT

- Perform the wiring carefully, in compliance with electromagnetic compatibility and safety requirements.
- Make sure the wiring is correct for its application.
- Use shielded cables for all I/O signal and communication cables.
- Minimise the length of the connections as much as possible, to avoid winding the cables around electrically connected parts.
- The signal (digital inputs, analogue inputs, communication and corresponding power supplies) and power cables for the device must be routed separately.
- Before applying the power supply, check all the wiring connections.
- Use the necessary safety interlocks wherever the risk of injury to personnel and/or equipment damage exists.
- Install and use this device in a cabinet of a suitable class for the intended environment, protected by a keyed locking mechanism or other suitable instruments.
- In terms of connection and the fuses used in the circuits for the power supply and output lines, observe local and national regulatory requirements relating to the nominal current and voltage for the equipment in use.
- Do not use this equipment for machine functions that are critical to safety.
- Do not disassemble, repair or modify the equipment.
- Do not connect wires to unused terminals and/or terminals marked with the text “No connection” (“N.C.”).

3.3 FRONT-MOUNTING MODEL DIMENSIONS

3.3.1 Vcolor 229/249 M user interface

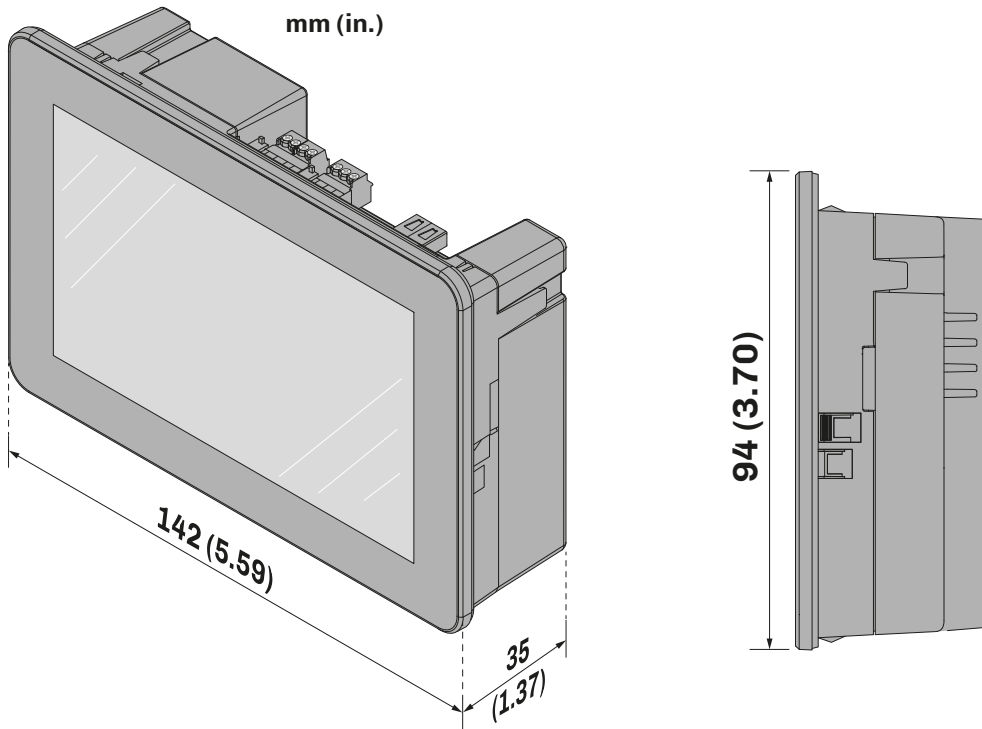

Fig. 1. Front-mounting Vcolor 229-249 M user interface dimensions

3.3.2 Vcolor 229/249 L user interface

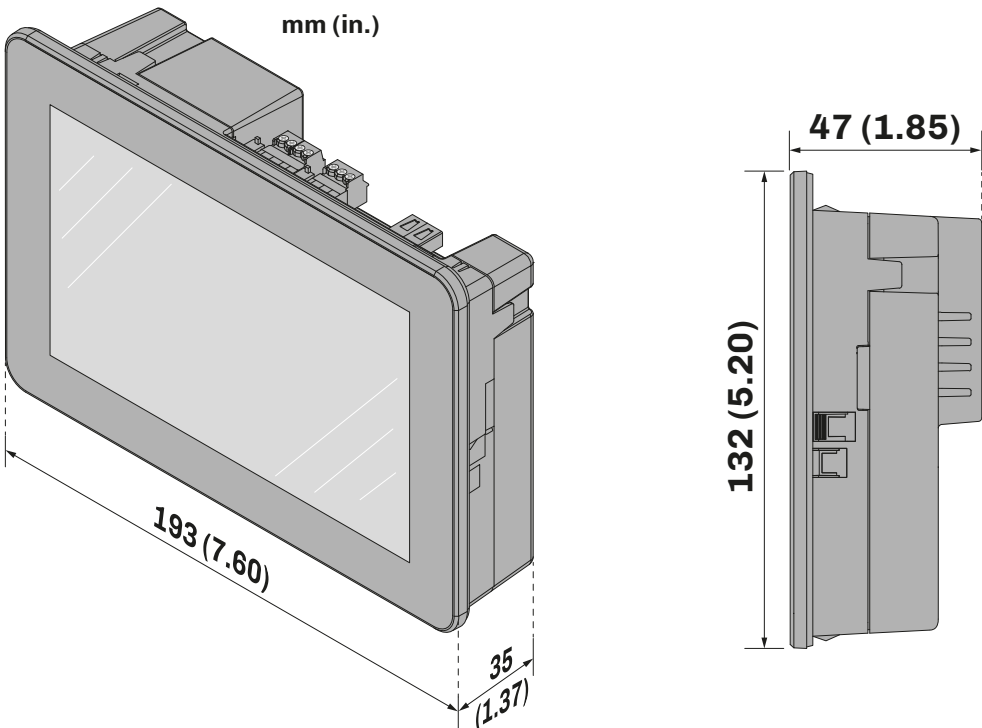

Fig. 2. Front-mounting Vcolor 229-249 L user interface dimensions

3.4 PANEL-BACK MOUNTING MODEL DIMENSIONS

3.4.1 Vcolor 229/249 M user interface

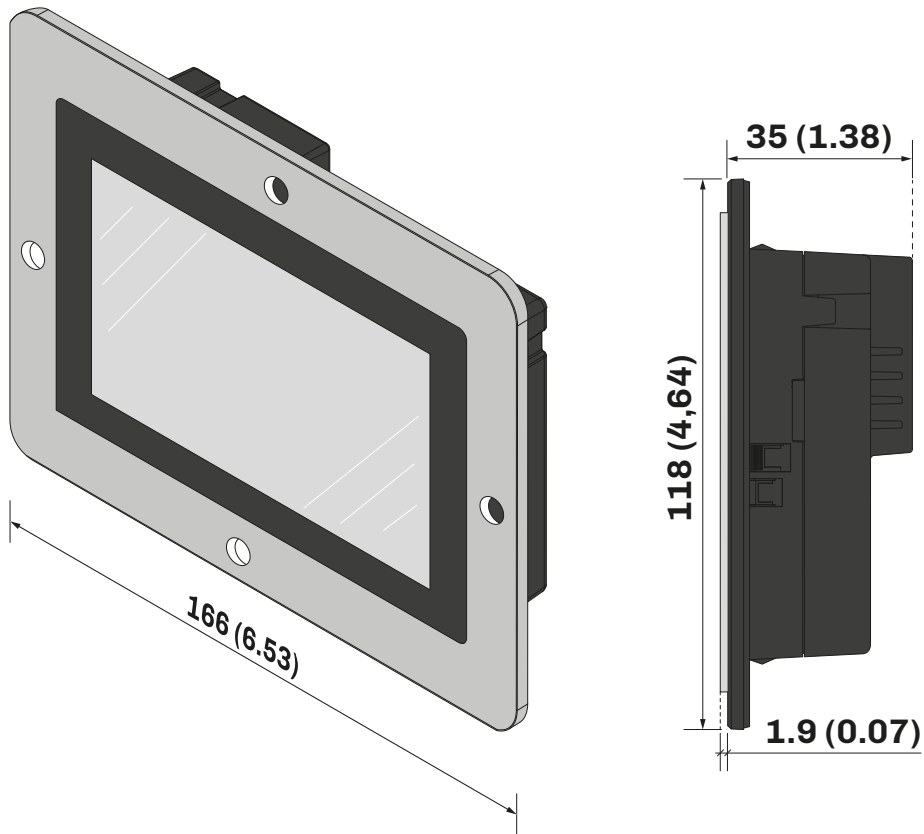

Fig. 3. Panel-back mounting Vcolor 229-249 M user interface dimensions

3.4.2 Vcolor 229/249 L user interface

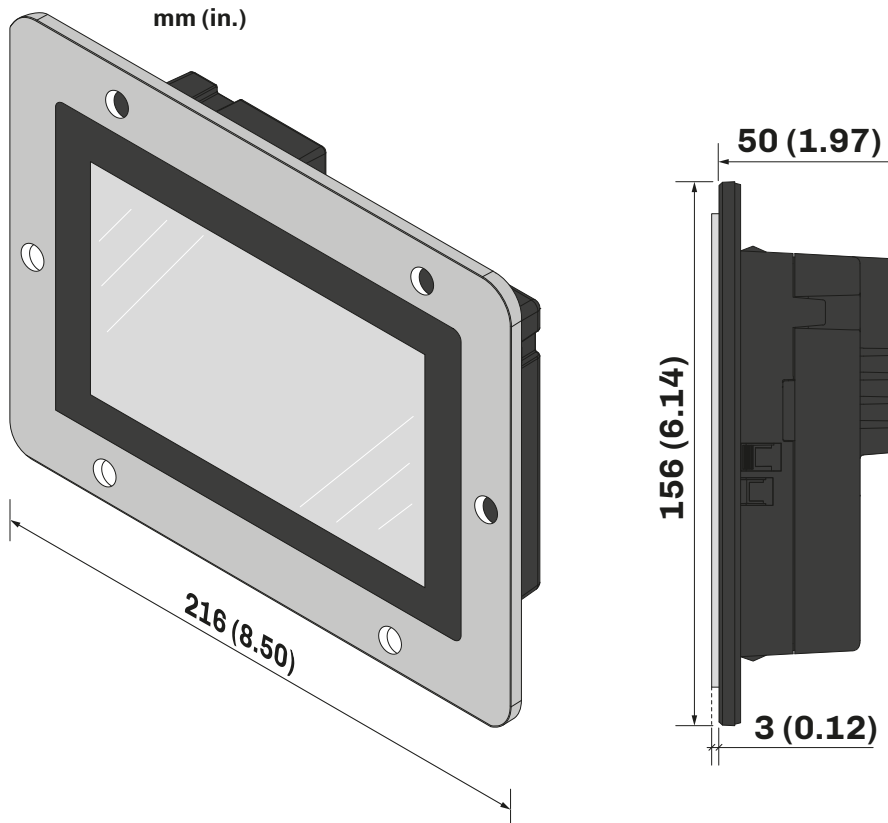

Fig. 4. Panel-back mounting Vcolor 229-249 L user interface dimensions

3.5 BASE BOARD DIMENSIONS

mm (in.)

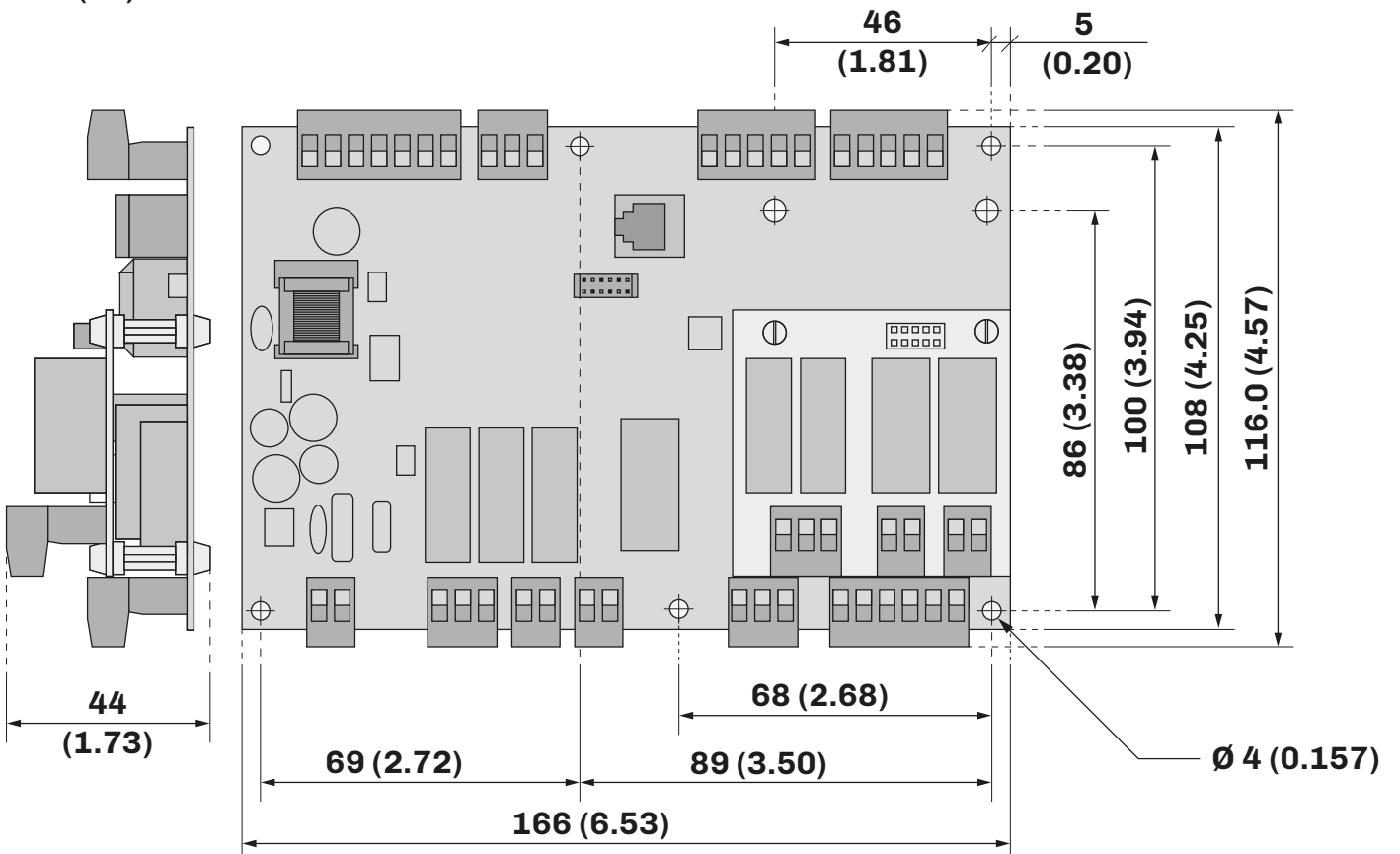

Fig. 5. Vcolor 229/249 M/L base board dimensions

3.6 VCOLOR 229/249 INSTALLATION

3.6.1 Wall mounting

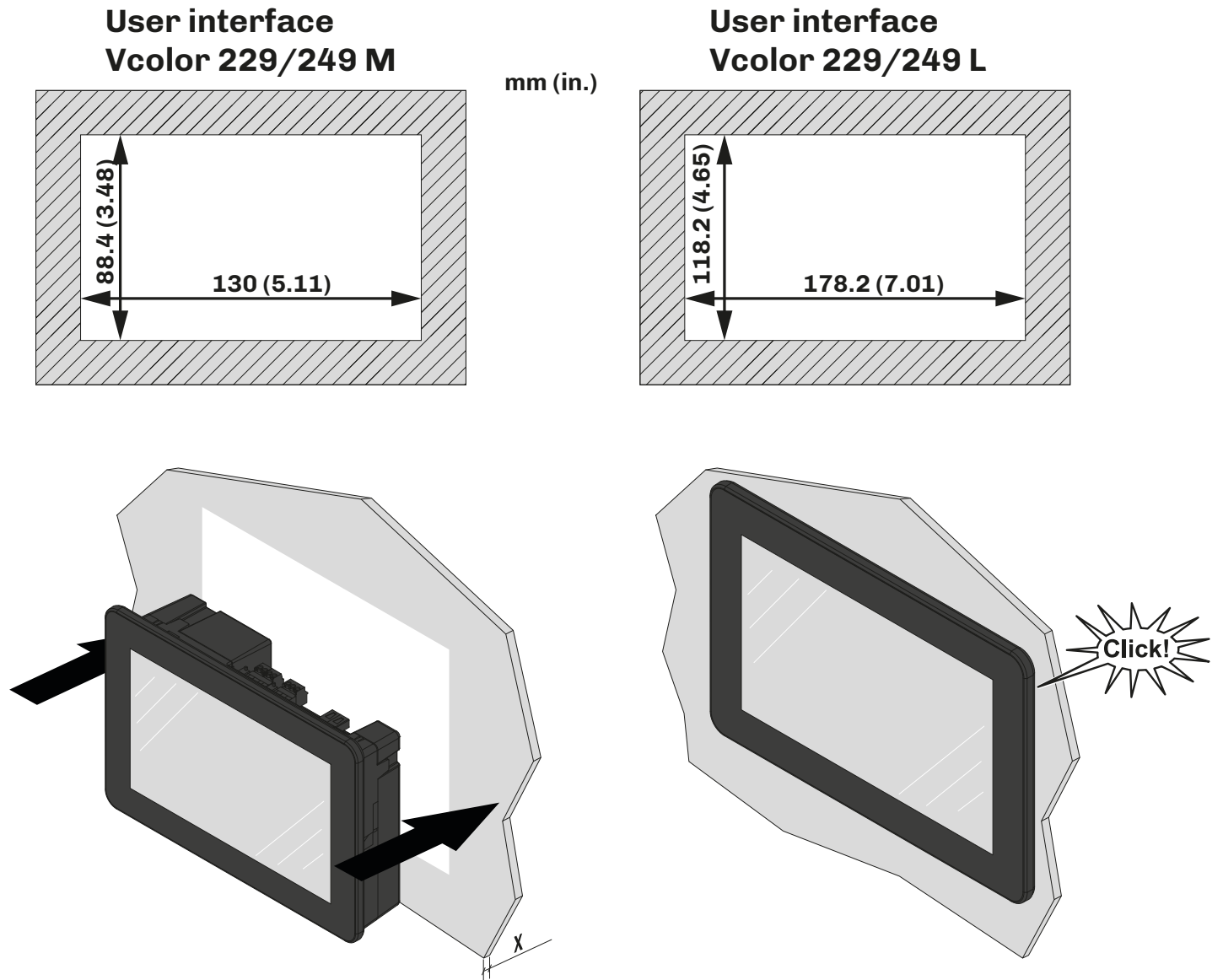

Fig. 6. Wall mounting the **Vcolor 229-249 M / Vcolor 229-249 L** user interface

Panel thickness

This panel thickness varies depending on the material used to make it:

Material	Thickness (X) [mm (in.)]
Metal	0.8...1.5 (0.03...0.06)
Plastic	0.8...3.4 (0.03...0.13)

3.6.2 Panel-back mounting

Vcolor 229/249 M user interface

mm (in.)

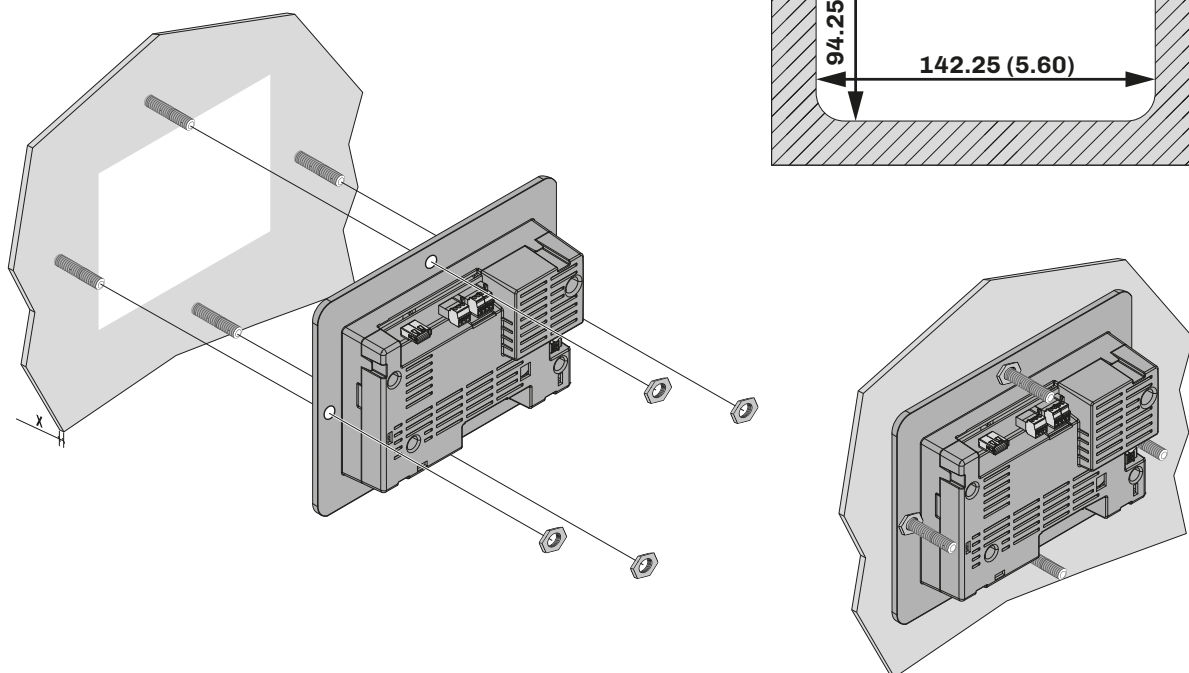

Vcolor 229/249 L user interface

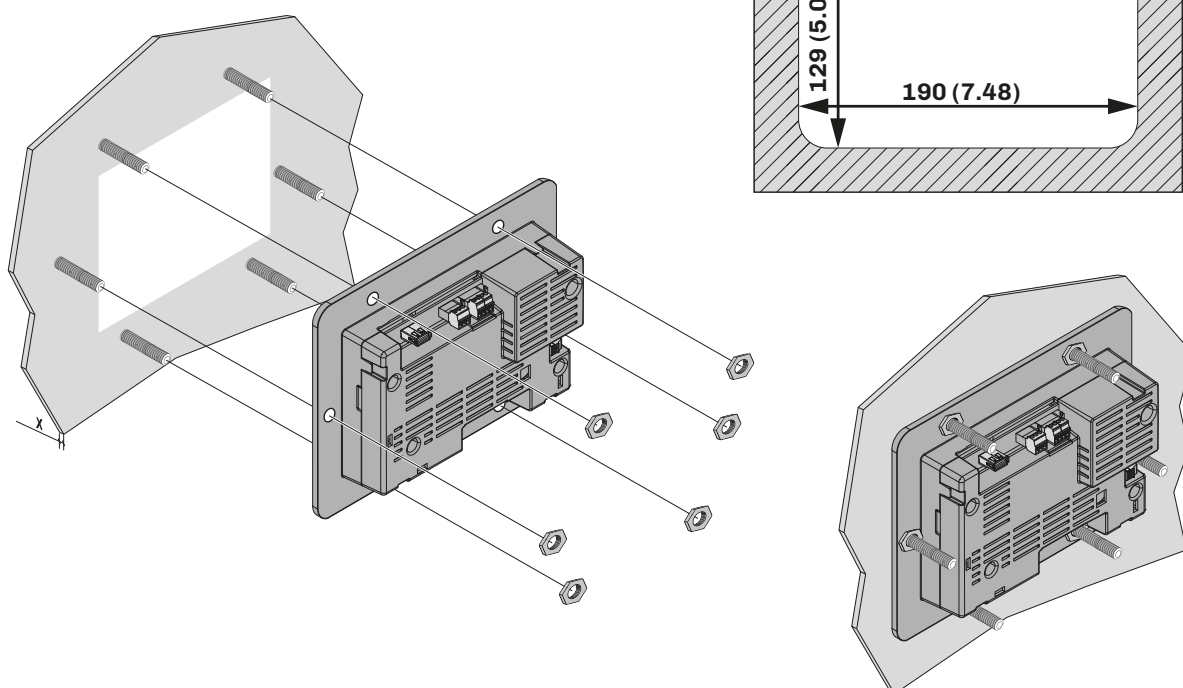

Fig. 7. Mounting the **Vcolor 229-249 M / Vcolor 229-249 L** user interface on the back of a panel

Panel thickness

The thickness of the metal panel used for installation on the back of a panel varies depending on the model:

Model	Thickness (X) [mm (in.)]
Vcolor 229/249 M	1.9 (0.07)
Vcolor 229/249 L	3.0 (0.12)

Captive screw hole spacing for Vcolor 229/249 M user interface

The metal panel used for installation on the back of a panel should take account of the captive screws to be fitted to it, in accordance with the following measurements:

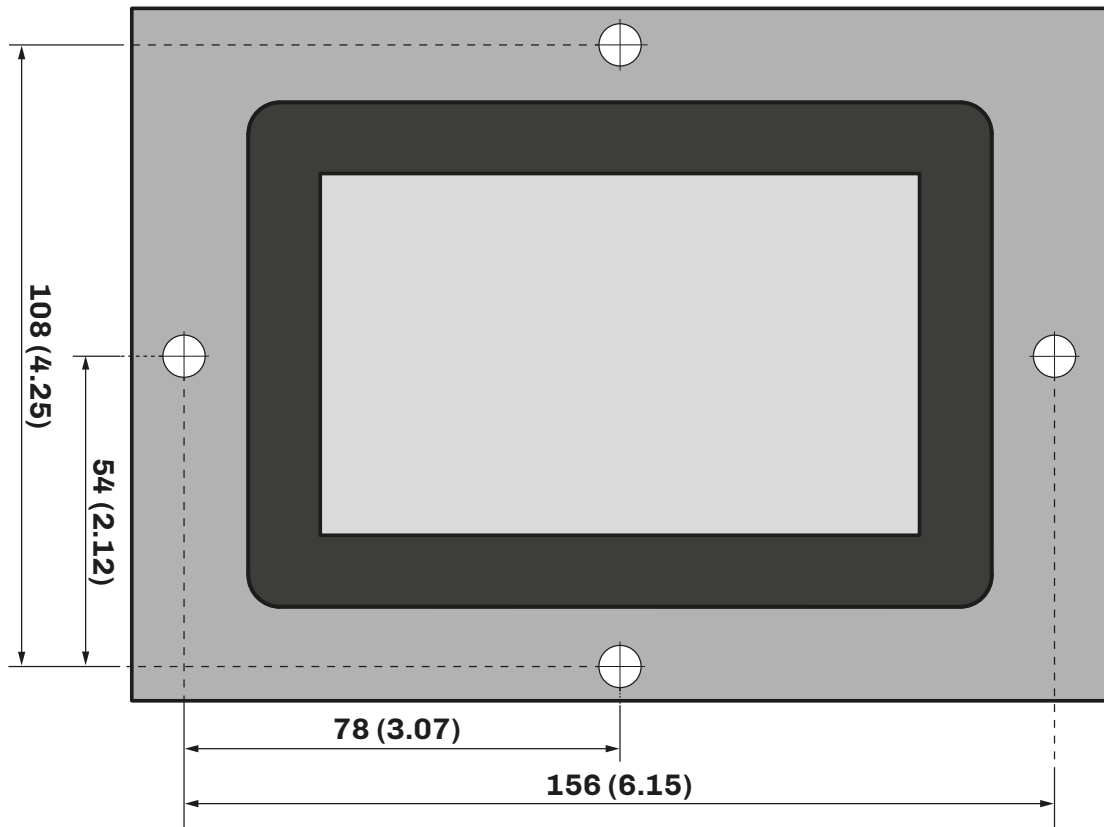

Fig. 8. Captive screw hole spacing measurements for **Vcolor 229/249 M**

Captive screw hole spacing for Vcolor 229/249 L user interface

The metal panel used for installation on the back of a panel should take account of the captive screws to be fitted to it, in accordance with the following measurements:

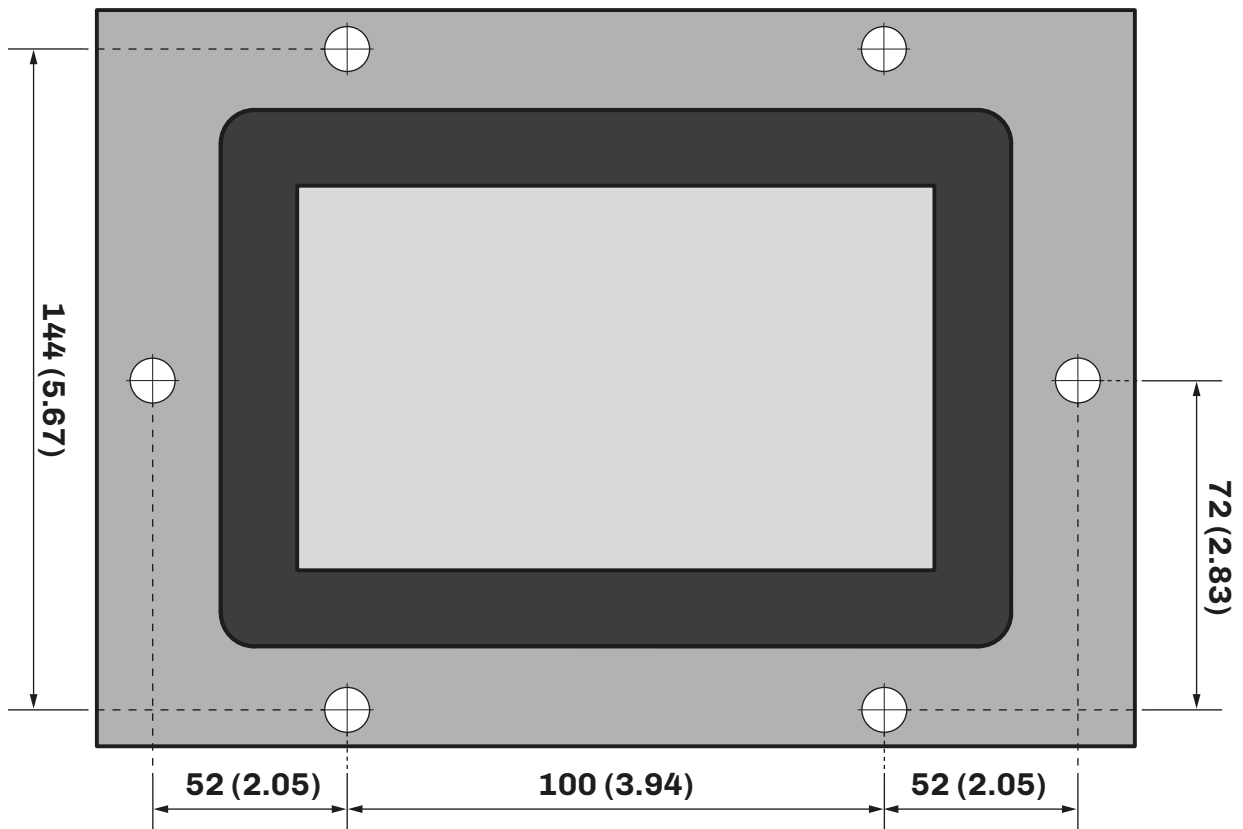

Fig. 9. Captive screw hole spacing measurements for **Vcolor 229/249 L** user interface

3.7 BASE POWER BOARD INSTALLATION

Base power board installation anticipates the use of plastic spacers (not supplied).

3.8 MINIMUM INSTALLATION DISTANCES

3.8.1 Vcolor 229/249 M/L user interface

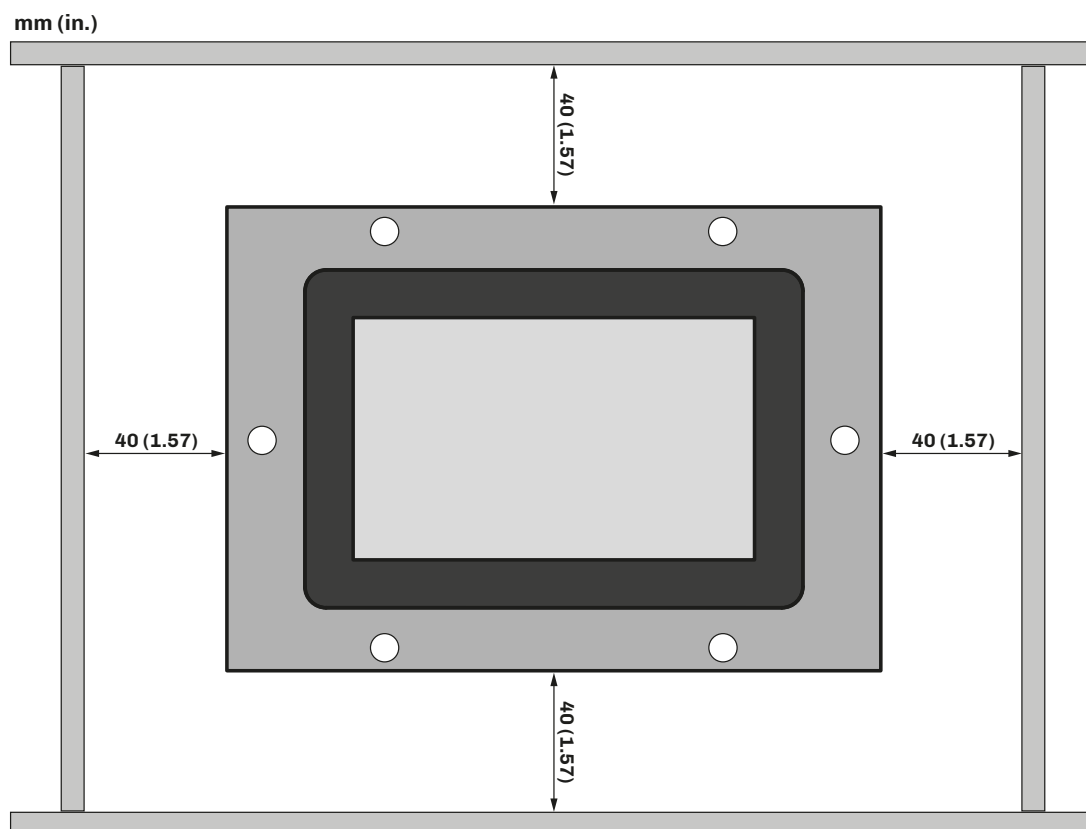

Fig. 10. Vcolor 229/249 M/L user interface minimum installation distances

3.8.2 Base board

Observe the minimum distance of 40 mm (1.57 in.) on each side when installing the base board.

4. ELECTRICAL CONNECTIONS

4.1 WIRING BEST PRACTICES

The following information describes the wiring guidelines and best practices which should be observed when using the equipment described in this user manual.

DANGER

RISK OF ELECTRIC SHOCK, EXPLOSION OR ELECTRIC ARC

- Only use electrically insulated measuring devices and equipment.
- Do not install the equipment while the power supply is connected.
- Cut off the power supply to all equipment, including any connected devices, before installing/uninstalling the device.
- Always use a properly calibrated Voltmeter to make sure the system is powered off.
- Do not touch the unshielded components or the terminals while they are live.
- Do not open, disassemble, repair or modify the product.
- Do not expose the equipment to liquids or chemicals.
- Before applying voltage to the equipment:
 - Make sure all protective elements, such as covers, hatches and grilles, are fitted and/or closed.
 - Check all wiring connections.

4.1.1 Wiring guidelines

When wiring the controllers, observe the following standards:

- The I/O and communication wiring must be kept separate from the power supply wiring. These two types of wiring must be routed in separate ducts.
- Make sure the operating environment and conditions fall within the specified values.
- Use wires with the correct diameter, suited to the voltage and current requirements.
- Use copper conductors (compulsory).
- Use shielded twisted pair cables for analogue/digital I/O connections.

Use correctly earthed shielded cables for all inputs or analogue outputs and for communication connections. If shielded cables are not used for these connections, electromagnetic interference may cause signal degradation. Degraded signals can result in unpredictable operation of the controller or the modules and connected equipment.

WARNING

MALFUNCTIONING OF THE EQUIPMENT

- Perform the wiring carefully, in compliance with electromagnetic compatibility and safety requirements.
- Make sure the wiring is correct for its application.
- Use shielded cables for all I/O signal and communication cables.
- Minimise the length of the connections as much as possible, to avoid winding the cables around electrically connected parts.
- The signal (digital inputs, analogue inputs, communication and corresponding power supplies) and power cables for the device must be routed separately.
- Before applying the power supply, check all the wiring connections.
- Use the necessary safety interlocks wherever the risk of injury to personnel and/or equipment damage exists.
- Install and use this device in a cabinet of a suitable class for the intended environment, protected by a keyed locking mechanism or other suitable instruments.
- In terms of connection and the fuses used in the circuits for the power supply and output lines, observe local and national regulatory requirements relating to the nominal current and voltage for the equipment in use.
- Do not use this equipment for machine functions that are critical to safety.
- Do not disassemble, repair or modify the equipment.
- Do not connect wires to unused terminals and/or terminals marked with the text “No connection” (“N.C.”).

4.1.2 Guidelines for screw terminals

Suitable wiring for power supply and SELV I/O

Step 5.08 mm (0.199 in.)

									Ø 3.5 mm (0.14 in.)	C	N•m 0.5...0.6 lb-in. 4.42...5.31	
	mm ²	0.2...2.5	0.2...2.5	0.25...2.5	0.25...2.5	2 x 0.2...1	2 x 0.2...1.5	2 x 0.25...1				2 x 0.5...1.5
	AWG	24...14	24...14	22...14	22...14	2 x 24...18	2 x 24...16	2 x 22...18				2 x 20...16

Fig. 11. Suitable wiring for the power supply

Suitable wiring for I/O SELV

Step 3.5 mm (0.137 in.)

									Ø 2.5 mm (0.09 in.)	C	N•m 0.22...0.25 lb-in. 1.94...2.21	
	mm ²	0.14...1.5	0.14...1.5	0.25...1.5	0.25...0.5	2 x 0.08...0.5	2 x 0.08...0.5	2 x 0.25...0.34				2 x 0.5...0.5
	AWG	28...16	28...16	22...16	22...20	2 x 28...20	2 x 28...20	2 x 22...21				2 x 20...20

Fig. 12. Suitable wiring for I/O SELV

4.1.3 Permitted cable lengths

NOTICE
INOPERABLE EQUIPMENT
<ul style="list-style-type: none"> • When connecting the probes, the digital inputs and the power supply, use cables that are no longer than 10 m (32.80 ft.). • When connecting the TTL serial port, use cables that are no longer than 1 m (3.28 ft.). • When connecting the controller power supply and the relay outputs, use cables that are no longer than 10 m (32.80 ft.).

4.2 WIRING DIAGRAM

4.2.1 Vcolor 229/249 M user interface

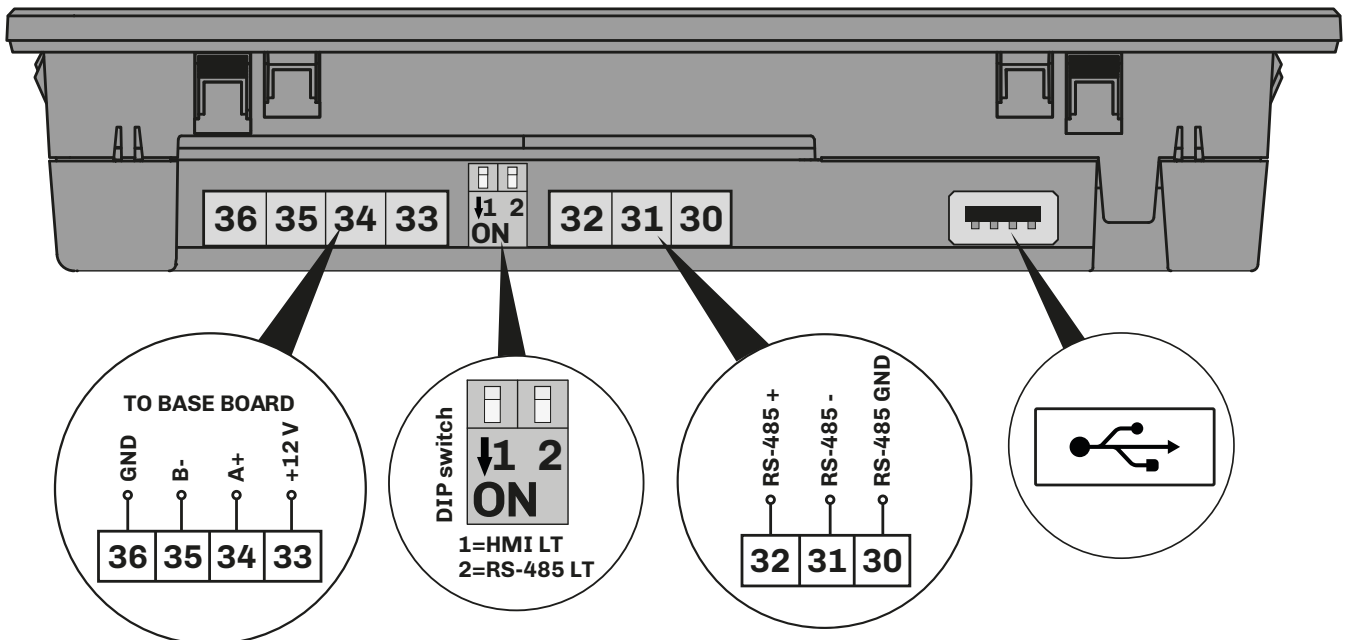

Fig. 13. Vcolor 229/249 M/L user interface wiring diagram

TERMINALS	
30	RS-485 GND serial port connection
31	RS-485 - serial port connection
32	RS-485 + serial port connection
33-36	Power supply input (12 Vdc from base board)
34-35	Connection for communication with the base board
PE	Earth connection
DIP switch	1 = Activation of HMI serial port termination resistor
	2 = Activation of RS-485 serial port termination resistor

4.2.2 Vcolor 229/249 L user interface

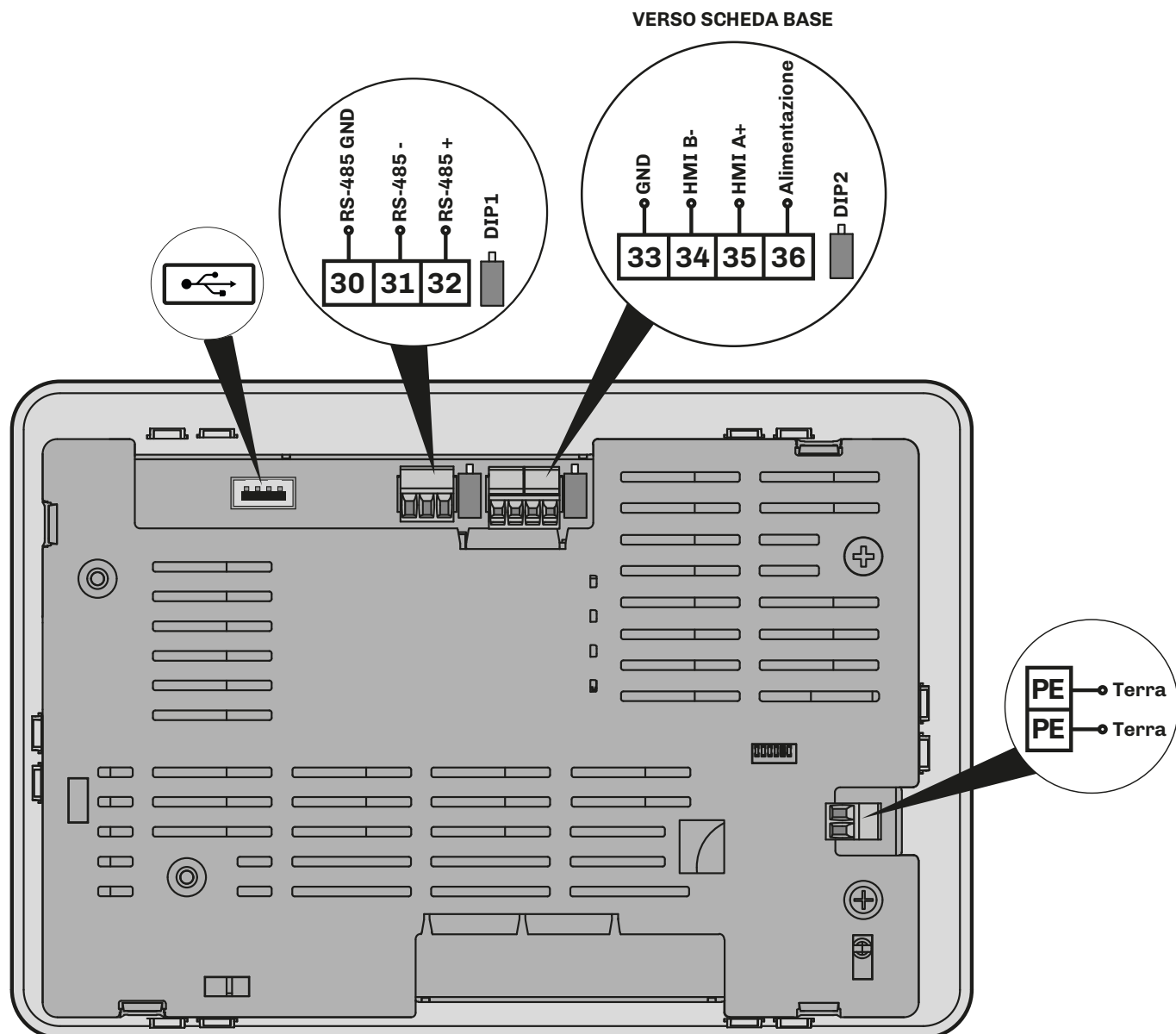

Fig. 14. Vcolor 229/249 L user interface wiring diagram

TERMINALS			
30	RS-485 GND serial port connection	34-35	Connection for communication with the base board
31	RS-485 - serial port connection	PE	Earth connection
32	RS-485 + serial port connection	DP1	Activation of RS-485 serial port termination resistor
33-36	12 Vac/dc power supply input	DP2	Activation of HMI serial port termination resistor

4.2.3 Vcolor 229 M/L base board

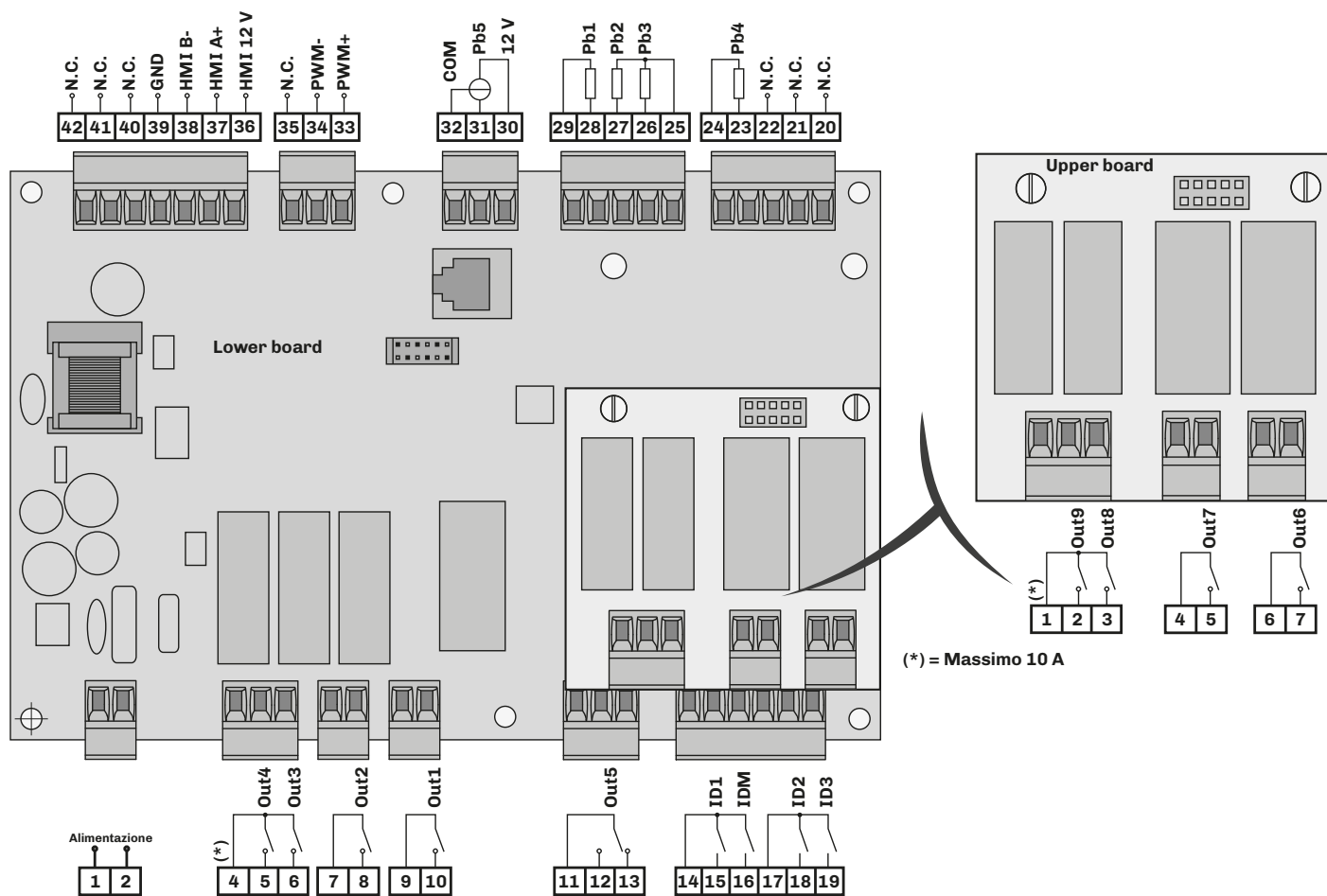

Fig. 15. Vcolor 229 M/L base board wiring diagram

LOWER BOARD TERMINALS			
1-2	Power supply input	23-24	Analogue input Pb4 (humidity probe EVHTP520)
4-5	Digital output Out4 (see u4c)	25-26	Analogue input Pb3 (see Pr3)
4-6	Digital output Out3 (see u3c)	25-27	Analogue input Pb2 (see Pr2)
7-8	Digital output Out2 (see u2c)	28-29	Analogue input Pb1 (see Pr1)
9-10	Digital output Out1 (see u1c)	30...32	Analogue input Pb5 (humidity probe 4...20 mA)
11...13	Digital output Out5 (see u5c)	33	Analogue output PWM- for fan driver
14-15	Digital input ID1 (see i4)	34	Analogue output PWM+ for fan driver
14-16	IDM door switch digital input	35	No connection N.C.
17-18	Digital input ID2 (see i7)	36-39	12 Vdc power supply output for Vcolor 229/249 M user interface
17-19	Digital input ID3 (see i11)	37-38	HMI user interface communication serial port connection
UPPER BOARD TERMINALS			
1-2	Digital output Out9 (see u9c)	4-5	Digital output Out7 (see u7c)
1-3	Digital output Out8 (see u8c)	6-7	Digital output Out6 (see u6c)

4.2.4 Vcolor 249 M/L base board

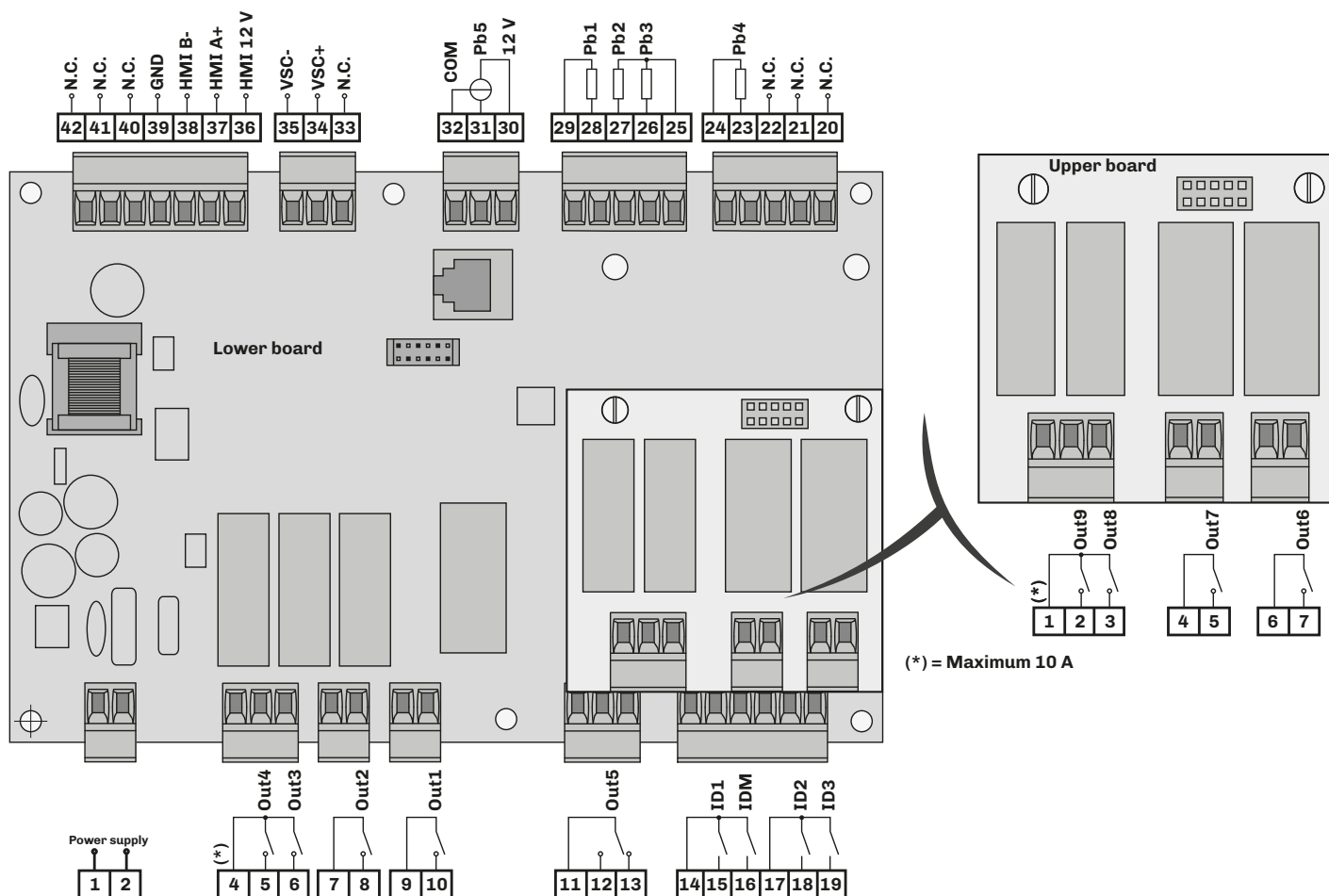
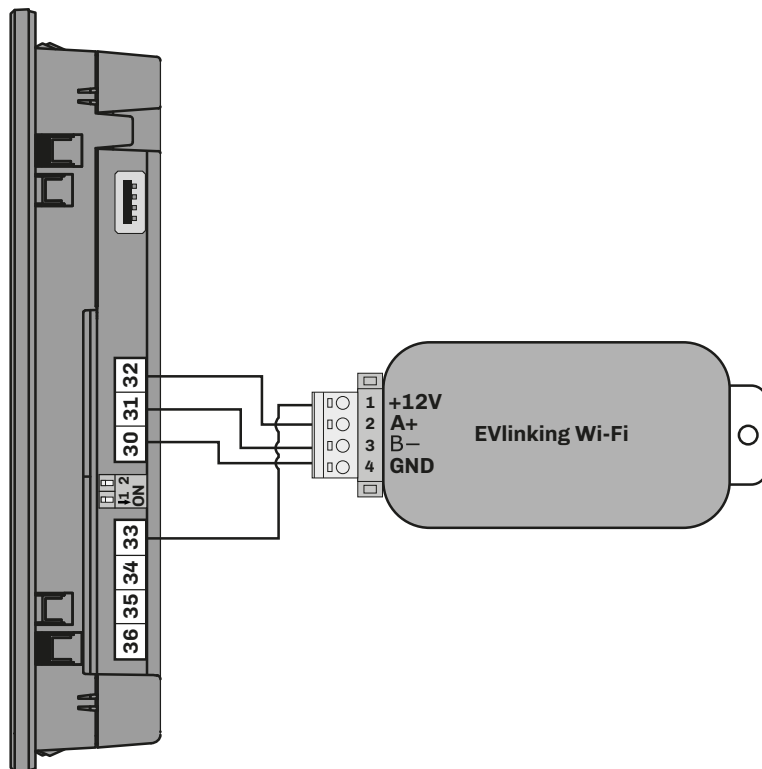

Fig. 16. Vcolor 249 M/L base board wiring diagram

LOWER BOARD TERMINALS			
1-2	Power supply input	23-24	Analogue input Pb4 (humidity probe EVHTP520)
4-5	Digital output Out4 (see u4c)	25-26	Analogue input Pb3 (see Pr3)
4-6	Digital output Out3 (see u3c)	25-27	Analogue input Pb2 (see Pr2)
7-8	Digital output Out2 (see u2c)	28-29	Analogue input Pb1 (see Pr1)
9-10	Digital output Out1 (see u1c)	30...32	Analogue input Pb5 (humidity probe 4...20 mA)
11...13	Digital output Out5 (see u5c)	33	No connection N.C.
14-15	Digital input ID1 (see i4)	34	Analogue output 0...10 V VSC+
14-16	IDM door switch digital input	35	Analogue output 0...10 V VSC-
17-18	Digital input ID2 (see i7)	36-39	12 Vdc power supply output for Vcolor 229/249 M user interface
17-19	Digital input ID3 (see i11)	37-38	HMI user interface communication serial port connection
UPPER BOARD TERMINALS			
1-2	Digital output Out9 (see u9c)	4-5	Digital output Out7 (see u7c)
1-3	Digital output Out8 (see u8c)	6-7	Digital output Out6 (see u6c)

EVlinking Wi-Fi connection

Vcolor 229/249 M user interface



Vcolor 229/249 L user interface

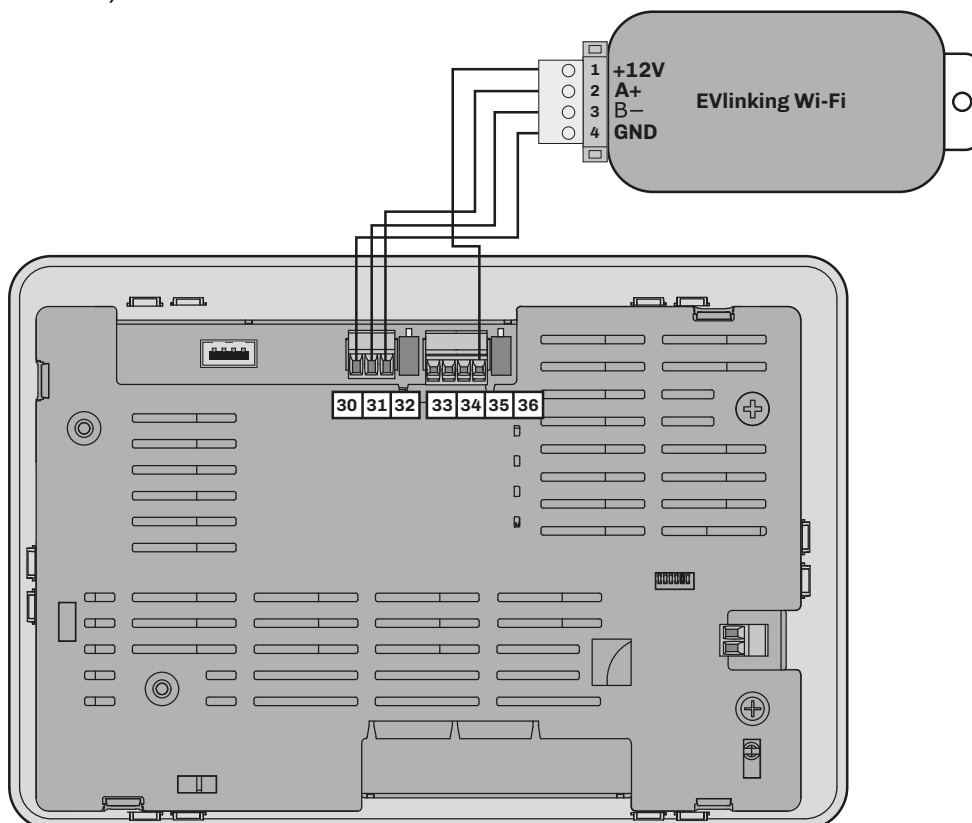

Fig. 17. EVlinking Wi-Fi connection diagram

5. USER INTERFACE

5.1 INTERFACE

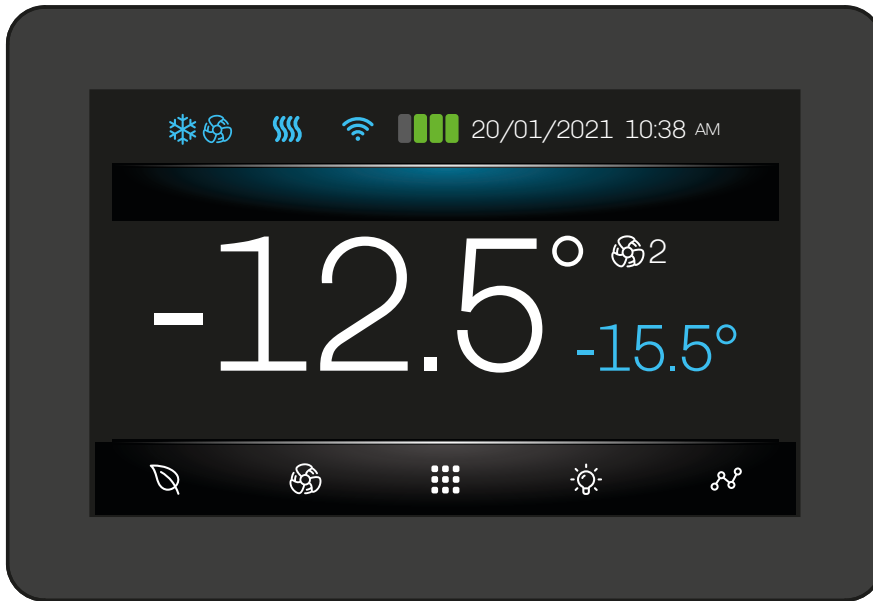







Fig. 18. User interface

5.2 ICONS

Icon	Lit steadily	Flashing	OFF
	Compressor ON	Protection delay ON	Compressor OFF
	Defrosting in progress	Dripping	---
	Evaporator fans ON	---	Evaporator fans OFF
	Humidification in progress	---	---
	Dehumidification in progress	Dehumidification delay with compressor ON	---
	Heating ON	---	Heating OFF
	Device connected to the monitoring system	Attempting to connect to the monitoring system	Device not connected to the monitoring system
	Energy Saving mode ON	---	Energy Saving mode OFF
	Energy Saving mode OFF	---	Energy Saving mode ON
	Selected fan speed 1	---	---
	Selected fan speed 2	---	---
	Selected fan speed 3	---	---
	Selected fan speed 4	---	---
	Selected fan speed 5	---	---
	Access to User level	---	---
	Access to Expert level (if configured)	---	---
	Access to Admin level (if configured)	---	---

5.3 TOUCH KEYS

The touch key functions are described below:

Keys...	Tap and release to...
	Access the temperature data-logger chart
	(If configured) Switch the cold room light on/off
	Access the menu
	(If configured) Select the evaporator fan speed
	Enable/disable energy saving mode

5.4 USING THE CONTROLLER

5.4.1 Controller ON/OFF

To switch the controller on or off, proceed as follows:

Power on



Power off



Fig. 19. Controller ON/OFF

NOTE: By switching on/off we mean switching from STANDBY to ON and vice-versa.

While the controller is in standby, tap ; the light will come on.

5.4.2 Screensaver

After a period of inactivity, which can be set via parameter **E8** ≠0, the controller launches its screensaver function, only showing the values of the connected probes on the display. When **E8** = 0, the screensaver function is disabled.

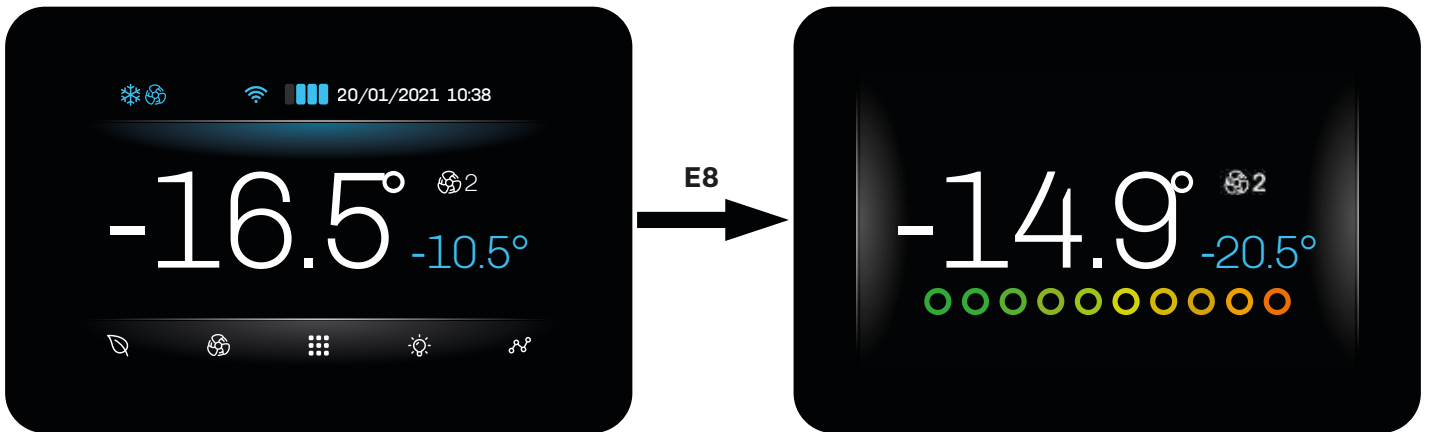

Fig. 20. Display during screensaver mode

5.4.3 Accessing and using the menu



The menu key on the Home screen is used to enter the menu offering access to the main functions used to configure and manage the **Vcolor 229/249**. To move on to the next page, tap  or .



Fig. 21. Menu access

The menu can be used to access the following functions:

- Switch off the device;
- Start manual defrost;
- View active alarms and/or event log;
- Access the lists of food to store (pre-set and favourites);
- Access special cycles;
- Access general settings, advanced functions and parameter management;
- Service menu;
- Lock/unlock the keyboard;
- Manage the connected humidifier.

5.5 DATA LOG

In the **data log** menu, you can view:

- Compressor counter log;
- Defrost log;
- Door open log;
- Setup log;
- Delete data log.



Fig. 22. Data log

Compressor counter log

- Total hours of machine operation;
- Total hours of compressor operation;
- Average compressor ON time;
- Average compressor OFF time;
- Percentage daily on time;
- Percentage compressor on time in the last hour.

Defrost log

- Report of the last 30 defrost cycles:
 - Defrost type;
 - Defrost start date and time;
 - Defrost duration.

Door open log

- Report of the last 30 door open events:
 - Total number of door open events;
 - Number of door open events that triggered a door open alarm;
 - Total door open time.

HACCP.CSV FILE configuration

- Enable/disable data to be stored in the log.

Delete log

- Delete one or more data groups individually or delete all data.

5.6 DOOR LOCK/UNLOCK

The menu can be used to lock/unlock the door as follows:



Fig. 23. Door lock/unlock

5.7 GENERAL SETTINGS

The general settings of the controller can be used to:

- Change the date and time;
- Change the language;
- Assign a name to the unit;
- Add a welcome page;
- Delete the list of favourite food.



Fig. 24. General settings

5.7.1 Change Date and Time



Fig. 25. Change Date and Time

You can choose a format, by tapping :

- Europe (EU);
- United States (USA).

5.7.2 Change language



Fig. 26. Change language

The default languages are:

- English;
- Italiano (Italian);
- Spanish;
- German;
- French;
- Russian;
- Simplified Chinese;
- Traditional Chinese.

5.7.3 Assign a name to the unit

In this section you can assign a name to the unit, or change an existing name. The name and the serial number can be up to 10 characters long.

The name of the unit features in the naming convention of the files that can be downloaded onto the USB stick.



Fig. 27. Assign a name to the unit

5.7.4 Delete favourite foods to store

This function is used to delete all data in the list **Favourite foods to store**. The password is required to confirm the procedure.



Fig. 28. Delete favourite foods to store

5.7.5 Welcome page

When the welcome page is enabled, the next time the controller is switched on it will ask you to perform some settings. The settings requested are:

- Unit name;
- Date and time;
- Device language;
- Temperature unit of measure.



Fig. 29. Welcome page

5.8 CHANGE EVAPORATOR FAN SPEED

Depending on the configuration of parameter **E13**, you can change the speed of the evaporator fans by tapping  (or not). Possible configurations are:

Par.	Description	MU	Range
E13	Evaporator fan configuration. 0 = Fans at speed 1 (with an output u1c...u13c = 3); 1 = Fans at speed 2 (with an output u1c...u13c = 3 and u1c...u13c = 11); 2 = Fans at speed 5 via output 0...10 Vdc; 3 = Fans at speed 5 via PWM output; 4 = Fans at speed 2 with 2 relays (with an output u1c...u13c = 3 and u1c...u13c = 11).	---	0...4

Example of speed change using a key with E13 = 1



Fig. 30. Change evaporator fan speed

5.9 ENERGY SAVING / ECO MODE

Depending on the configuration of parameter **ES0**, you can adjust the Energy Saving/Eco function of the controller by pressing  on the Home screen.

Possible configurations are:

Par.	Description	MU	Range
ES0	Energy saving mode. 0 = 1 level (Disabled/High saving); 1 = 3 levels (Disabled/Low saving/Medium saving/High saving).	num	0/1

ES0 = 0

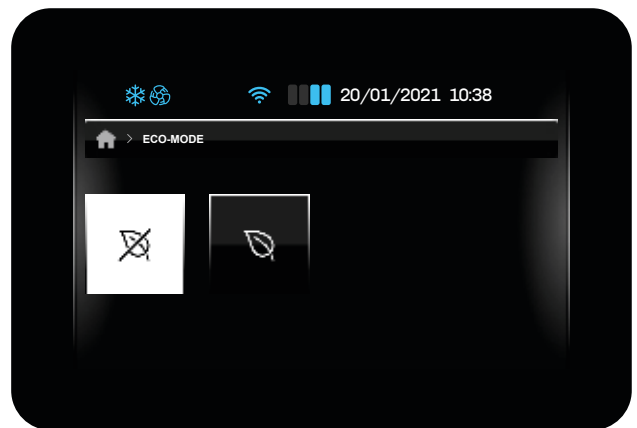

ES0 = 1

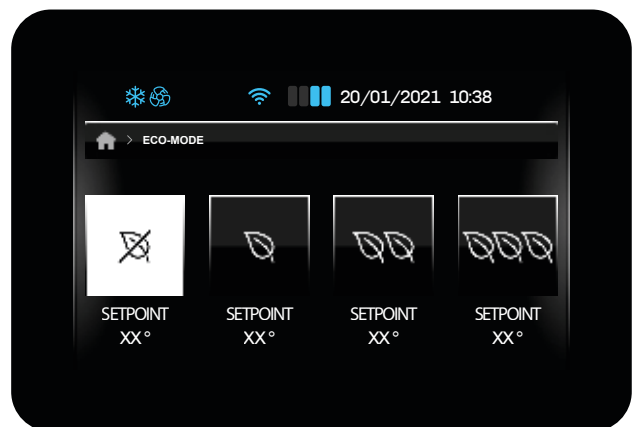
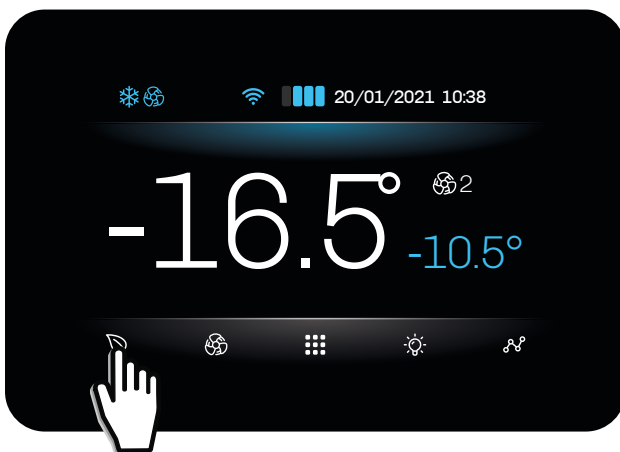

Fig. 31. Energy saving mode activation

5.10 COLD ROOM LIGHT

You can switch the cold room light on or off from the Home screen. Switching on the cold room light takes priority over the door switch: if the light is switched on via key, opening and closing the door will have no effect on the light, which remains on, until it is switched off with the key. The cold room light can also be switched on/off even when the instrument is OFF.



Fig. 32. Switching cold room light on/off

5.11 MANUAL DEFROST

In the required conditions, a manual defrost can be launched from the menu. Proceed as follows:



Fig. 33. Manual defrost

If the conditions are not as required for a manual defrost, the following screen appears on the display:



Fig. 34. Manual defrost not possible

5.12 FAVOURITE FOODS TO STORE (PRE-SET AND FAVOURITES)

Vcolor 229/249 is factory-set with two groups of foods:

- **OEM** group;
- **USER** group.

5.12.1 OEM group

The **OEM** is mainly intended for manufacturers who need full autonomy in customising food storage.

Up to 72 foods grouped into up to 8 categories can be configured in the OEM group. Each category can contain up to 12 foods accompanied by a photo and recipe name (with the corresponding translation in all desired languages).

5.12.2 USER group

The **USER** group is dedicated to end users; up to 48 foods can be saved, starting with a product saved in the OEM group. Categories cannot be created in the **USER** group.

If no products are placed in a category, that category is not shown.



Fig. 35. Favourite foods to store - pre-set and favourites

Action	USER group	OEM group
Import	√	√
Export	√	X
Change	√ ⁽¹⁾	√
Add	√ ⁽¹⁾	√
Delete	√	X
Favourites	√	√
Overwrite	√ ⁽¹⁾	X

⁽¹⁾ Recipes in the USER group can be added, changed or overwritten, beginning with at least one recipe from the OEM group.

5.13 ALARMS

In the event of an alarm indication, the description of the current alarm appears in red on the home screen (as in the example below) and the buzzer sounds (if enabled).

If there are several active alarms, they alternate on the home screen, each appearing for 3 seconds at a time.

Touch the screen next to the alarm indication to silence the buzzer; the controller will automatically switch to showing the list of active alarms.

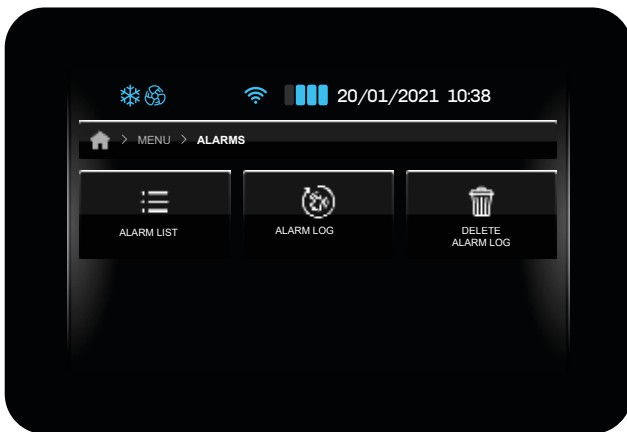
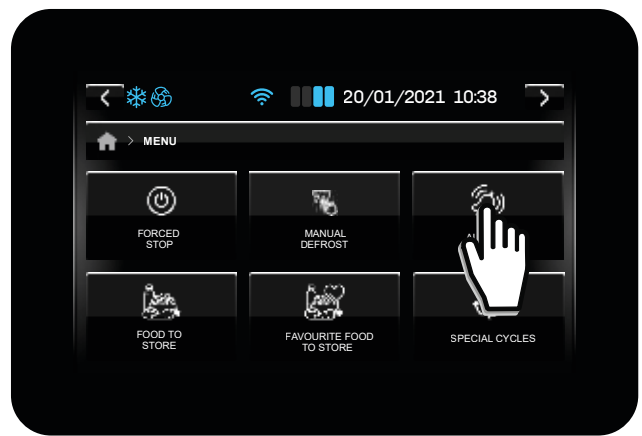
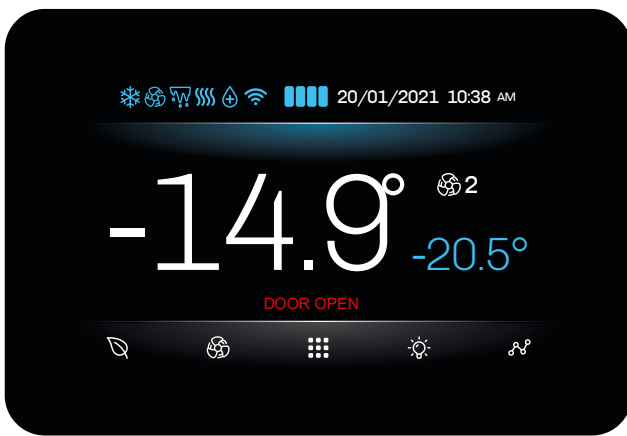

Fig. 36. Alarm indications

5.13.1 Active alarm list

Press Alarm list to access the active alarms screen. This list includes:

- Standard alarms (on resetting they are not saved in the alarm log and are deleted from the list of active alarms);
- HACCP alarms (on resetting they are saved in the alarm log).

The alarms menu is accessed from the general menu, and can be used to:

- View the active alarm list;
- View the alarm log;
- Delete the alarm log.



Fig. 37. Alarm indications

To view the full list of all alarms, please refer to the section **"9. Diagnostics"** on page 79.

5.13.2 Delete alarm log

To delete the alarm log:



Fig. 38. Delete alarm log

5.14 SPECIAL CYCLES

Vcolor 229/249 offers special cycles designed to allow the user full control of refrigerated cabinets or cold rooms.

The special cycles available are:

- Cooling;
- Continuous cycle;
- Sanitising (if SA0 ≠ 0);
- Thawing (if th23 ≠ 0).

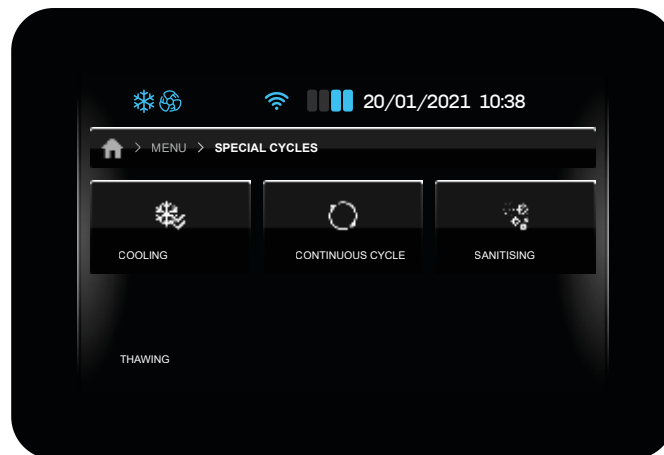

Fig. 39. Available special cycles display

While the **Cooling** and **Continuous cycle** are taking place, the controller automatically shows the HOME screen. The cycle in progress is shown at the top of the display. Touch the screen next to the cycle in progress indication to return to the special cycle screen.

While the **Sanitising** and **Thawing**, cycles are taking place, the controller remains on the screen for that cycle, until it has been completed.

5.14.1 Cooling

The **Cooling** cycle is used when the refrigerated cabinet is loaded for the first time. The controller runs a cabinet cooling cycle at maximum power until the setpoint is reached, or until the maximum time set during the cycle startup phase has elapsed. During the **Cooling** cycle, to view the remaining time, return to the special cycle screen.



Fig. 40. Cooling cycle

5.14.2 Continuous cycle

The **Continuous cycle** special cycle is used to pre-chill the cold room before foods are placed inside. The controller starts a cycle which will only end due to the maximum time period being reached (this value can be set during cycle startup), while the temperature is not checked.

During the **Continuous cycle**, to view the remaining time, return to the special cycle screen.



Fig. 41. Continuous cycle

5.14.3 Sanitising

If **SA0** \neq 0, the **Special cycles** menu will include the **Sanitising** cycle among the options available for selection.

Sanitising can be carried out with:

- A UV lamp, if **SA0** = 1;
- An Ioniser/Ozone generator, if **SA0** = 2.

Both **Sanitising** methods can only be activated when the door is closed.

The conditions required to start the **Sanitising** cycle are:

- Door closed;
- Cold room probe temperature (Pb1) > **SA1**;

The duration of the cycle is determined by **SA2**; if **SA0** = 2, the cycle duration is **SA2+SA3** (in addition to time SA2, a time **SA3** is added).

CAUTION

RISK OF ULTRAVIOLET RADIATION AND POISONING

Do not open the door while sanitising is in progress.

While the cycle is in progress, the fan is ON (when the door is open the fan switches off), while regulation is disabled until the end of the cycle.



Fig. 42. Sanitising cycle

5.14.4 Thawing

If TH23 = 1, the **Special cycles** menu will include the **Thawing** cycle among the options available for selection.

Thawing is managed in accordance with the amount of product which needs to be thawed, in relation to the maximum amount as declared by the manufacturer.

The cycle runs with a neutral zone (hot-cold) during thawing and in cold-only mode during storage.

While **Thawing** is in progress, the controller inhibits normal operation until the user ends the cycle manually.

There are 3 levels of thawing:

- Low;
- Medium;
- High.

Depending on the selected level, suitable parameters must be configured:

Level...	Initial cold room setpoint	End cold room setpoint	Cycle duration
Low	tH01	tH04	tH07
Medium	tH02	tH05	tH08
High	tH03	tH06	tH09

The thawing cycle is divided into 5 phases, distinguished by the abovementioned parameters:

LOW level

Phase...	Working setpoint...
1	Phase 1 = tH01
2	Phase 2 = Phase 1 setpoint - [(tH01-tH04)/4]
3	Phase 3 = Phase 2 setpoint - [(tH01-tH04)/4]
4	Phase 4 = Phase 3 setpoint - [(tH01-tH04)/4]
5	Phase 5 = tH04

MEDIUM level

Phase...	Working setpoint...
1	Phase 1 = tH02
2	Phase 2 = Phase 1 setpoint - [(tH02-tH05)/4]
3	Phase 3 = Phase 2 setpoint - [(tH02-tH05)/4]
4	Phase 4 = Phase 3 setpoint - [(tH02-tH05)/4]
5	Phase 5 = tH05

HIGH level

Phase...	Working setpoint...
1	Phase 1 = tH03
2	Phase 2 = Phase 1 setpoint - [(tH03-tH06)/4]
3	Phase 3 = Phase 2 setpoint - [(tH03-tH06)/4]
4	Phase 4 = Phase 3 setpoint - [(tH03-tH06)/4]
5	Phase 5 = tH06

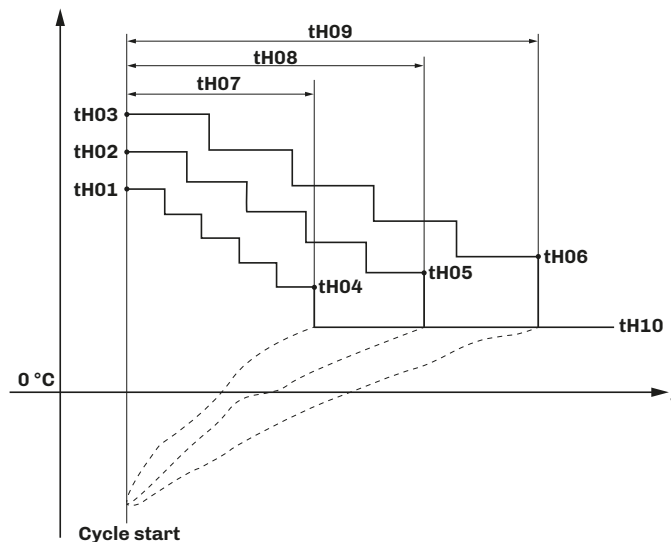

Fig. 43. Thawing cycle operation

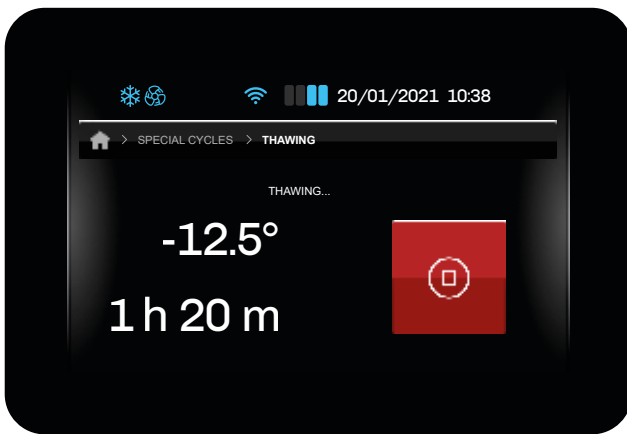
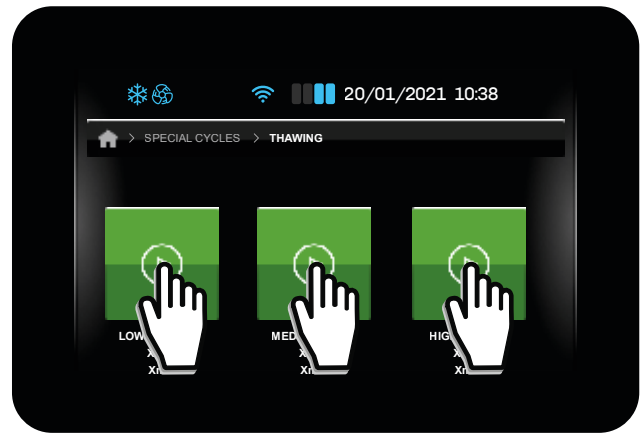
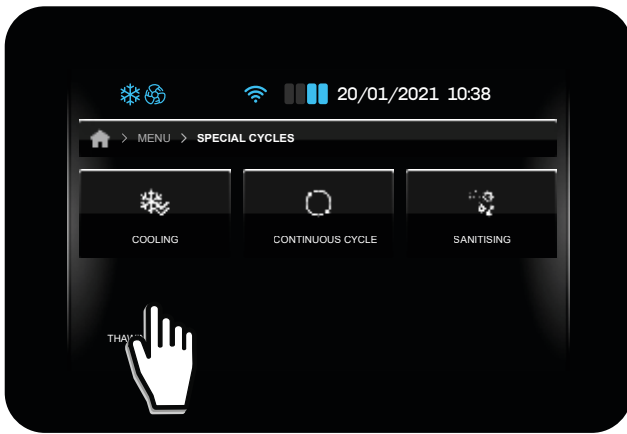

Fig. 44. Thawing cycle

The option of setting the evaporator fan speed is available for each phase of the thawing cycle.

Par.	Description	MU	Range
tH11	Evaporator fan speed during thawing phase 1.	---	1...5
tH12	Evaporator fan speed during thawing phase 2.	---	1...5
tH13	Evaporator fan speed during thawing phase 3.	---	1...5
tH14	Evaporator fan speed during thawing phase 4.	---	1...5
tH15	Evaporator fan speed during thawing phase 5.	---	1...5

Once the thawing cycle has ended, the buzzer sounds and the machine starts its storage phase, with setpoint tH10, for a limitless time. During this phase, the speed of the fans can be set via tH16:

Par.	Description	MU	Range
tH10	Storage phase setpoint.	°C/°F	-50.0...99.9
tH16	Fan speed for thawing storage phase.	---	1...5

During the thawing cycle, defrosting is inhibited, while during the storage cycle, defrosting is only performed at certain time/temperature intervals.

5.15 TEMPERATURE CHART

The **Temperature chart** which can be used to view the temperature data-logger chart can be accessed via the menu.

Parameter L1 can be used to set the timescale of the chart in steps of 5 minutes.

Par.	Description	MU	Range
L1	Data-logger sampling interval.	min	1...60

The sampling logic is as follows:

- L1 = 1, then the controller takes 12 samples at intervals of 1 minute (±12 min);
- L1 = 5, then the controller takes 12 samples at intervals of 5 minutes (±1 h);
- L1 = 10, then the controller takes 12 samples at intervals of 10 minutes (±2 h);
- L1 = 60, then the controller takes 12 samples at intervals of 60 minutes (±12 h);

The chart shows the temperature trends over the last 12 samples.

Key to line colours

- **Green line:** Cold room temperature;
- **Blue line:** Product temperature;
- **Yellow line:** Evaporator temperature;
- **Red line:** Condenser temperature.

The X-axis shows a vertical dotted line indicating sampling.

The Y-axis shows the minimum and maximum values detected, so as to show all the data within the display.

NOTE: After changing **L1**, delete the data log on the machine to cross-reference consistent saved data.

5.16 SERVICE

The **Service** menu can be used to:

- Manage users (only if **E18** = 1);
- View I/O status;
- View the battery status (only if **E19** = 2 or 3);
- Log in (access) (only if **E18** = 1).

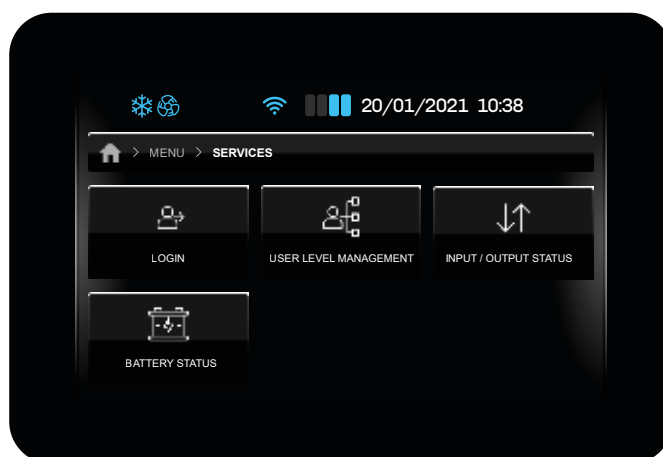

Fig. 45. Service menu

5.16.1 Login

The controller can be managed through 3 user levels:

- User;
- Expert (**PW: 125**);
- Admin (**PW: 250**) (menu access for the **Admin** level cannot be changed and always remain enabled).

Users are disabled by default (**E18** = 0).

Each user, if they have logged in, views all registered users, but editing individual users is only possible for users at a lower level, e.g. ADMIN users can edit all users, while EXPERT users can only edit USER users.

It is possible to set or change the password and enable/disable access to various menus and functions for each user, depending on their access level.

NOTE: once a user has logged out, the controller automatically enters USER level, and the Homepage displays the  icon.

NOTE: ADMIN and EXPERT level passwords can only be changed if you logged in as ADMIN.

5.16.2 I/O status

In the **Input-output status** section, you can consult the status of the inputs (analogue and digital) and outputs (digital and analogue). Only the values for the inputs and outputs configured via parameters are shown; other non-configured inputs and outputs will be followed by “—”.

5.16.3 Battery status

In the **Battery status** section, if the battery module is enables (**E19** = 2 or 3), the following will be displayed:

- The battery status (voltage);
- Whether the battery is charging or in use.

5.17 PARAMETER MANAGEMENT

The **Parameter management** menu can be used to edit parameters, or to restore all parameters to their factory values.



Fig. 46. Parameter management menu

5.17.1 Parameter settings

To access the **Parameter settings** section, you must enter the access password (-19). Once you have entered the password, you can access the **Parameter groups** screen, where you can select the group of parameters you wish to edit.



Fig. 47. Parameter settings

5.17.2 Restore parameters

To restore the parameters to their factory values, select the corresponding entry in the menu and enter the password 149.

5.18 ADVANCED FUNCTIONS

The **Advanced Functions** menu can be used to:

- Test the outputs;
- Run a test cycle.

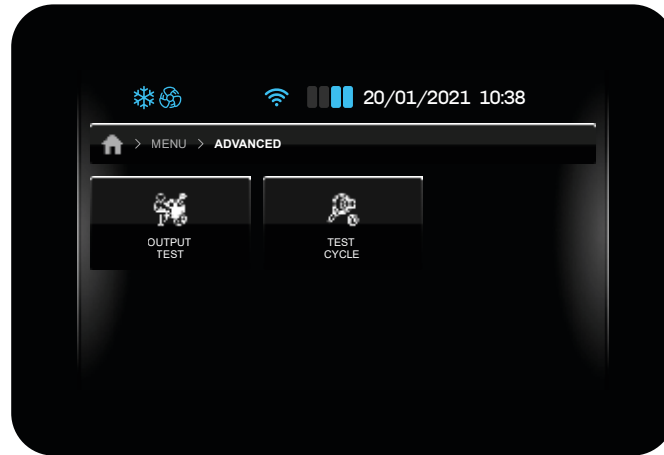

Fig. 48. Advanced functions menu

5.18.1 Output test

In the **Output test** section, you can activate/deactivate all outputs (digital/analogue) configured on the controller, regardless of the regulation currently taking place.

In this section, you can manually pause the regulation currently taking place; on exiting the menu, regulation resumes the paused task automatically.

Each output can be activated/deactivated individually.

5.18.2 Test cycle

All loads are switched off in the **Test cycle**.

The test cycle function automatically performs a test cycle consisting of 7 phases:

1. **Start test cycle:** Tap START;



Fig. 49. Start test cycle

2. **Cold room temperature for cycle start**

The cycle starts automatically as soon as Pb1 (cold room temperature) > T1;

3. **Pulldown phase**

The controller runs in cold mode until setpoint T2 is reached.

Correct probe connection is checked. §

The temperature of the evaporator probe should be lower than the temperature of the cold room, while the temperature of the condenser should be higher than that of the cold room. If it is not exceeded, the test ends.

The maximum Test duration is determined by T7; if the Test exceeds the time period T7, the text **MAX TIME** appears and the test ends.

4. Thermostat control phase

This phase runs with a Setpoint (T3) and Hysteresis (T4).

During this phase, the compressor performs a number of cycles T5 before moving on to the Defrost phase.

NOTE: by cycles we mean the compressor ON phase and OFF phase time.

5. Defrost phase

Once the Thermostat control phase has ended, the controller runs a forced defrost (determined by the defrost parameters).

If the defrost cycle ends due to Time, the text **DEFR. TIME** appears and the test ends.

6. Recovery phase

Once defrosting has ended, the controller waits for the temperature of the cold room to reach the setpoint T6.

7. Test complete

The controller switches off all loads and remains on the test screen, showing the results.



Fig. 50. Test cycle phases

5.19 MISTRAL HUMIDIFIER MANAGEMENT

Vcolor 229/249 M/L can manage the **Mistral** humidifier directly.
To enable management of the Mistral humidifier, set **E10** = 2.
The configuration parameters for the **Mistral** humidifier are:

Par.	Description	MU	Range
HS1	Minimum humidity setpoint value. With CFG = 2, 3, 4, 7, 8, 9.	%	0...100
HS2	Maximum humidity setpoint value. With CFG = 2, 3, 4, 7, 8, 9.	%	0...100
HS3	Minimum delay time between two consecutive humidity production activations. With CFG ≠ 10.	s	1...240
HS4	Fan speed. 0 = Fan off; 1 = Speed F1 ; 2 = Speed F2 ; 3 = Speed F3 .	---	0...3
HS5	Water conductivity.	μS*cm	70...1250
HS6	Number of continuous idle hours causing the water reservoir to empty. 0 = Function disabled.	h	0...250
HS7	Number of operating hours causing the water reservoir to empty. 0 = Function disabled.	h	0...250



Fig. 51. Humidifier management

5.19.1 Operating mode

Displays the humidifier operating values.

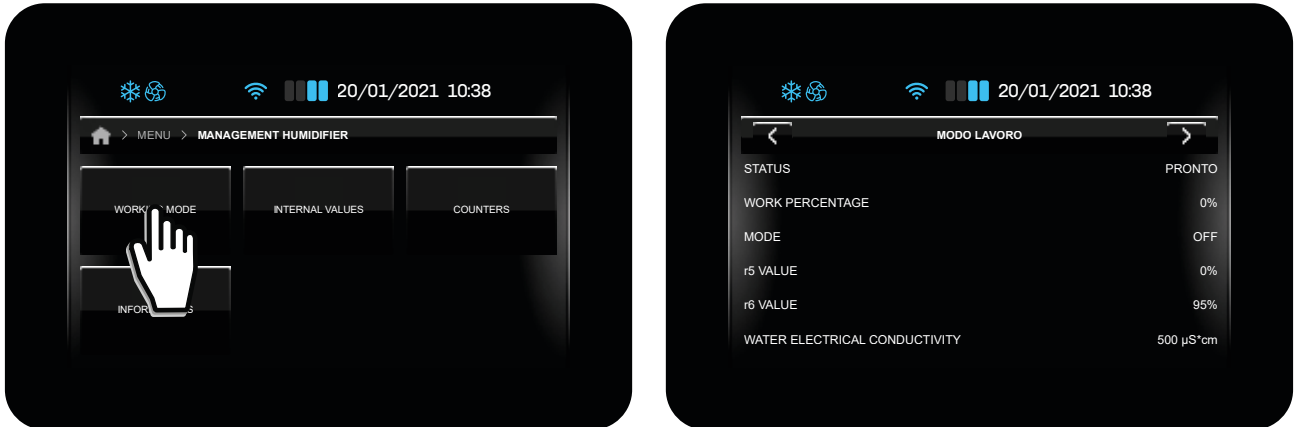

Fig. 52. Operating mode

5.19.2 Internal values

Displays the values of the humidifier operating variables.



Fig. 53. Internal values

5.19.3 Counters

Displays the mist-maker and fan operating hours.



Fig. 54. Counters

5.19.4 Information



Fig. 55. Information

6. DEFROSTING

6.1 INTRODUCTION

Defrosting is used to remove ice from the surface of the evaporator.

By default defrost is set to manual operation **d0** = 0. For automatic operation, set **d0** > 0.

The defrost configuration parameters are:

Par.	Description	MU	Range
d0	Automatic defrost interval.	h	0...99
d1	Defrost type. 0 = Electric heaters; 1 = Cycle inversion (hot gas); 2 = On compressor stoppage.	---	0...3
d2	Evaporator temperature over which defrost ends with evaporator probe (Pr1...Pr3 = 1).	°C/°F	-99.0...99.0
d3	Defrost duration.	min	0...99
d4	Enable defrost after power failure. 0 = No; 1 = Yes.	---	0/1
d5	Defrost delay after power failure (if d4 = 1).	min	0...99
d6	Display during defrost. 0 = Regulation temperature; 1 = Display locked; 2 = Defrosting in progress text.	---	0...2
d7	Evaporator drip time after a defrost.	min	0...15
d11	Enable alert for defrost end due to maximum duration. 0 = No; 1 = Yes.	---	0/1
d15	Consecutive compressor ON time before hot gas defrost.	min	0...99

Defrost starts once the time set in **d0** has elapsed, with the method set by **d1**.

The defrost duration is determined by **d3**, while the temperature threshold for the end of defrosting is determined by **d2**, if at least one analogue input **Pr1...Pr3** = 1 (evaporator probe active).

With **d11** = 1, an alert appears on the display (**dFd**), if the defrost has a duration greater than **d3** (only if **Pr1...Pr3** = 1).

When **d15** = 0, the function is disabled. If **d15** > 0, the compressor is forced to ON for the set time.

6.1.1 Operating conditions

Defrosting starts automatically, if the following conditions are met:

- Pb2 temperature below **d2**;
- Interval **d0** elapsed and Pb3 temperature under **d2**.

If a manual defrost is active or one of these two conditions is not satisfied, defrosting **does not** start automatically.

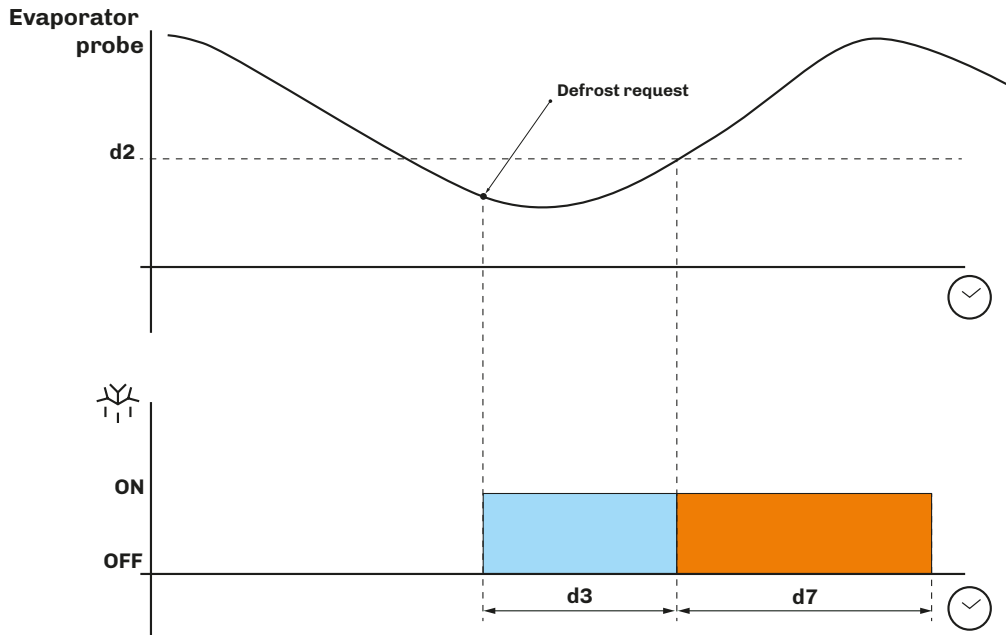

Fig. 56. Defrost with **Pr1...Pr3** = 1

6.1.2 Dripping interval

A dripping interval can be set following a defrost, by setting **d7** > 0, to prevent water from accumulating inside the evaporator and then freezing.

6.2 STANDARD DEFROST

To use this mode, set parameter **d1**.

Defrosting takes place by means of evaporator heating using one of the following methods:

Par.	Description	MU	Range
d1	Defrost type. 0 = Electric heaters; 1 = Cycle inversion (hot gas); 2 = On compressor stoppage.	---	0...3

6.2.1 Electric heater defrost

Electric heater defrost is achieved by setting **d1** = 0.

Defrost activation

When defrosting is activated:

- The compressor stops;
- The relay output to which the electric heaters are connected (configured as a defrost output) is activated.

Defrost end conditions

The defrost end conditions are:

- The defrost duration **d3** is reached;
- The defrost end temperature **d2** is reached.

The electric heater defrost configuration parameters are:

Par.	Description	MU	Range
C0	Compressor ON delay from power-on.	min	0...240
C2	Minimum compressor OFF time.	min	0...240
d0	Automatic defrost interval.	h	0...99
d1	Defrost type. 0 = Electric heaters; 1 = Cycle inversion (hot gas); 2 = On compressor stoppage.	---	0...3
d2	Evaporator temperature over which defrost ends with evaporator probe (Pr1...Pr3 = 1).	°C/°F	-99.0...99.0
d3	Defrost duration.	min	0...99
d7	Evaporator drip time after a defrost.	min	0...15

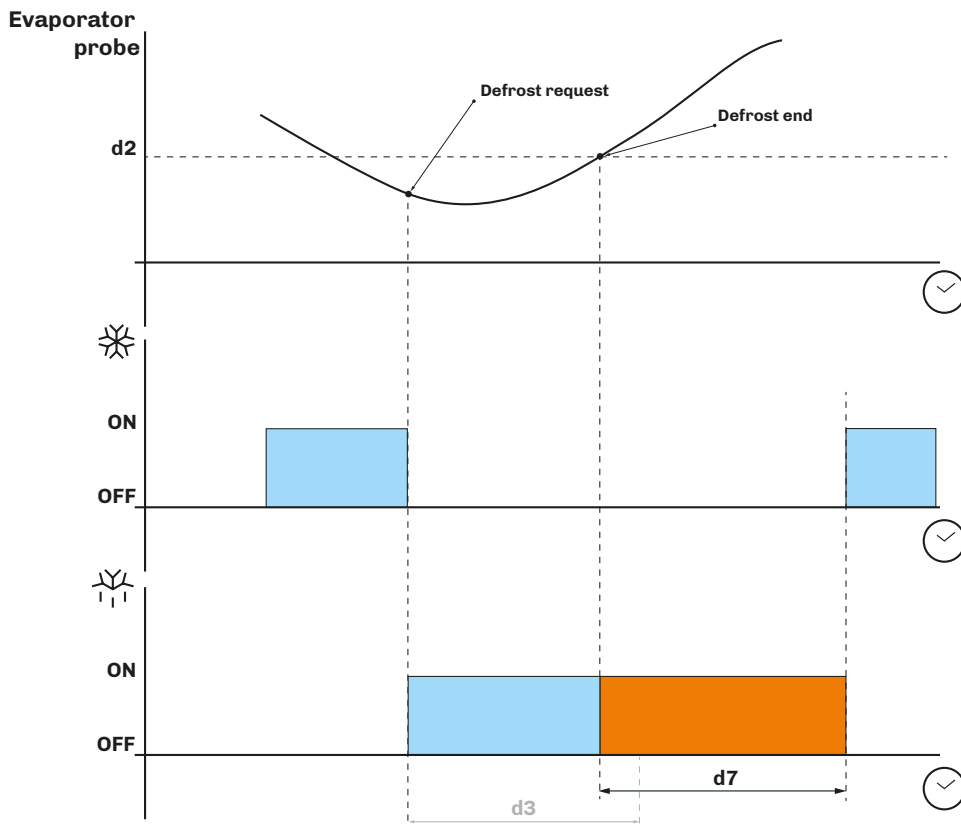

Fig. 57. Electric heater defrost - Defrost end due to temperature

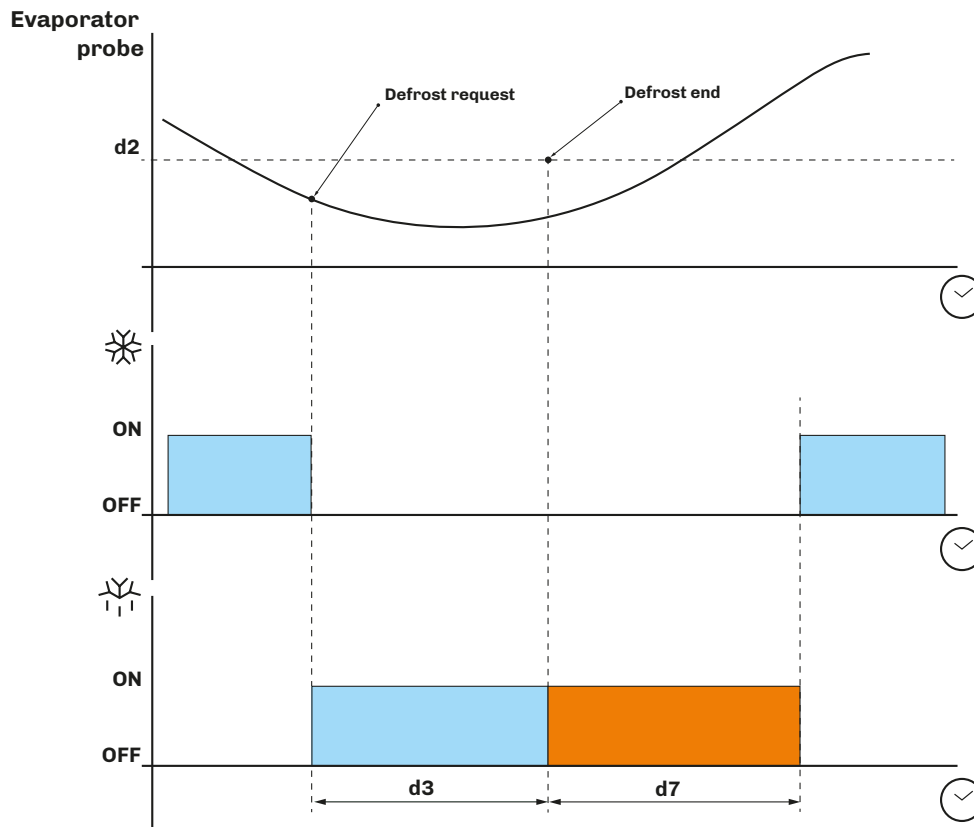

Fig. 58. Electric heater defrost - Defrost end due to maximum time

6.2.2 Cycle inversion (hot gas) defrost

Cycle inversion defrost is achieved by setting **d1** = 1.

Defrost activation

When defrosting is activated:

- The compressor is activated (or it has already been active for a time period **d15**) and remains so for the duration of the defrost;
- The relay output to which the valve is connected (solenoid if the system operates with a thermostatic valve) is activated.

Defrost end conditions

The defrost end conditions are:

- The maximum defrost duration, set via parameter **d3**, is reached.
- The defrost end temperature, set via parameter **d2**, is reached.

The cycle inversion defrost configuration parameters are:

Par.	Description	MU	Range
C0	Compressor ON delay from power-on.	min	0...240
C2	Minimum compressor OFF time.	min	0...240
d0	Defrost interval.	h	0...99
d1	Defrost type. 0 = Electric heaters; 1 = Cycle inversion (hot gas); 2 = On compressor stoppage.	---	0...3
d2	Evaporator temperature over which defrost ends with evaporator probe (Pr1...Pr3 = 1).	°C/°F	-99.0...99.0
d3	Defrost duration.	min	0...99
d7	Evaporator drip time after a defrost.	min	0...15
d15	Consecutive compressor ON time before hot gas defrost.	min	0...99

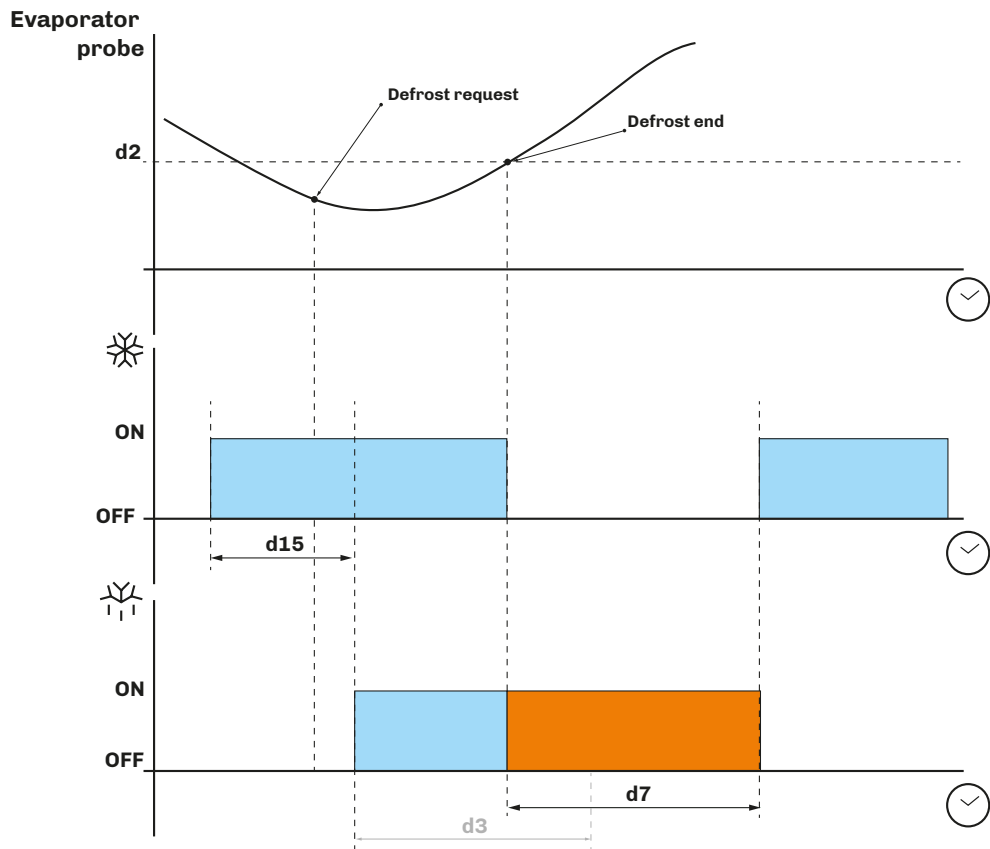

Fig. 59. Cycle inversion defrost - Defrost end due to temperature

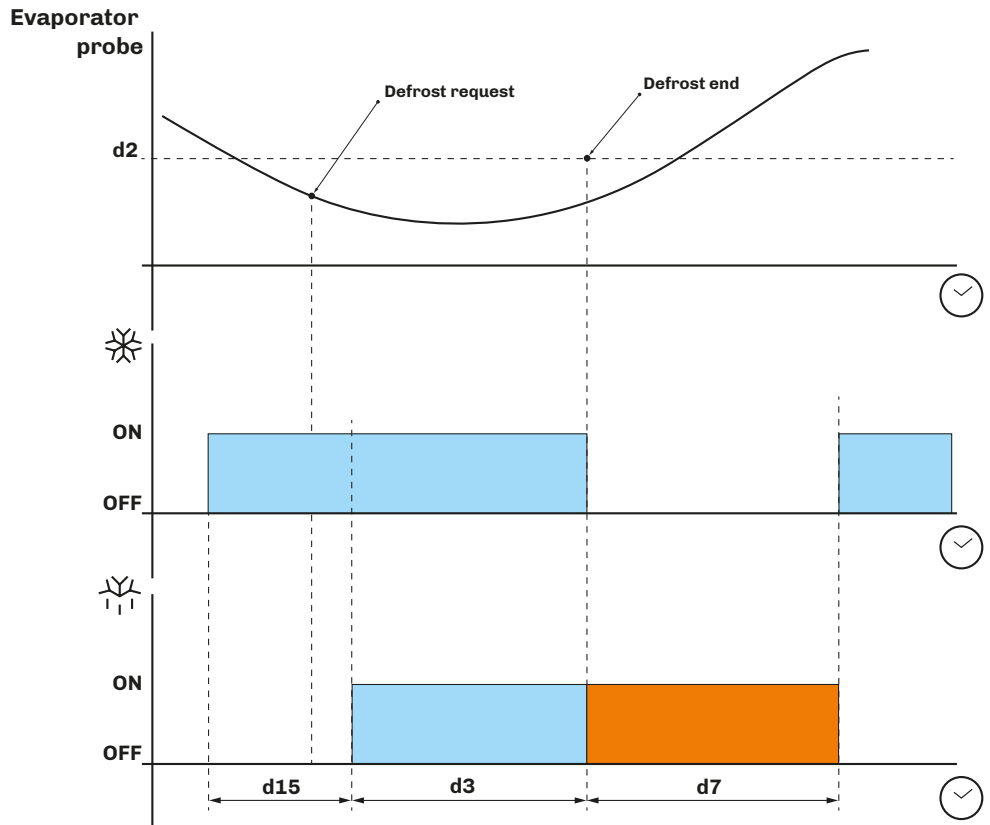

Fig. 60. Cycle inversion defrost - Defrost end due to maximum time

6.2.3 Defrost on compressor stoppage

Compressor stoppage defrost is achieved by setting **d1** = 2.

The compressor stoppage defrost configuration parameters are:

Par.	Description	MU	Range
d0	Defrost interval.	h	0...99
d1	Defrost type. 0 = Electric heaters; 1 = Cycle inversion (hot gas); 2 = On compressor stoppage.	---	0...3
d3	Defrost duration.	min	0...99
d7	Evaporator drip time after a defrost.	min	0...15

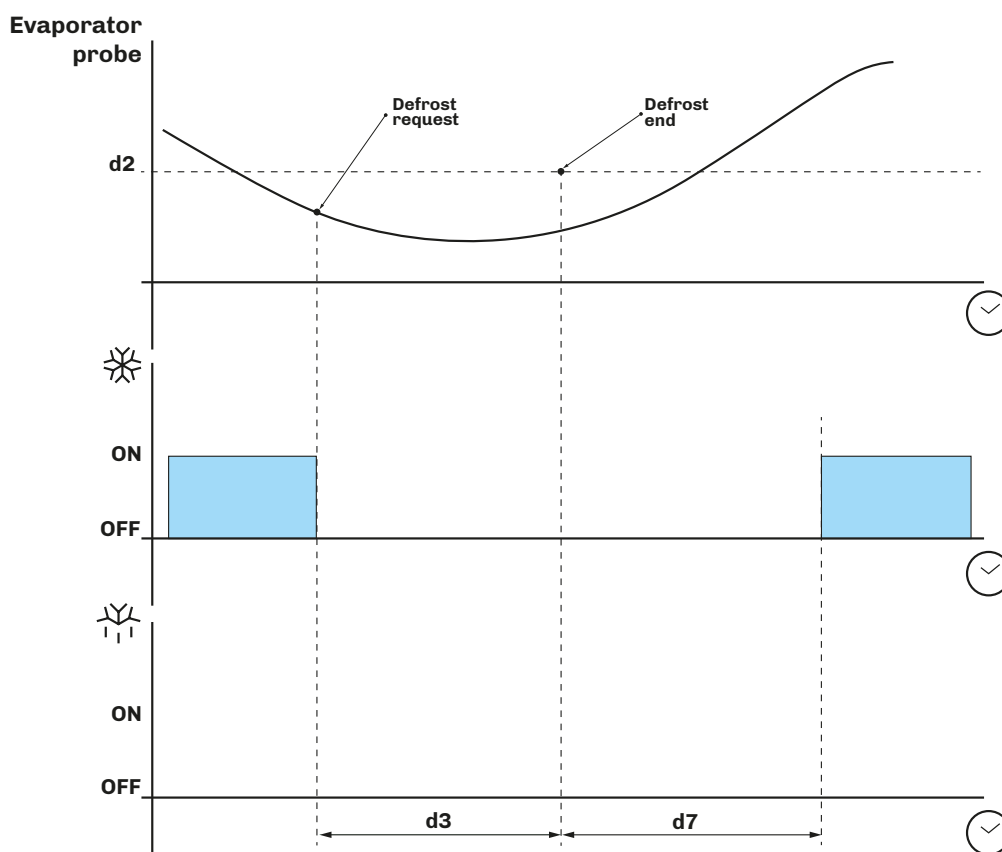

Fig. 61. Defrost on compressor stoppage

7. REGULATORS

7.1 HOT/COLD TEMPERATURE

The temperature regulation configuration parameters are:

Par.	Description	MU	Range
P15	Regulation type. 0 = Cold 1 = Hot; 2 = Hot/Cold with neutral zone.	---	0...2
rC0	Cold temperature regulation differential, to be added to setpoint 1 (setpoint 1 + rC0)	°C/°F	0.1...15.0
rC1	Minimum value that can be assigned to setpoint 1.	°C/°F	-99.9... rC2
rC2	Maximum value that can be assigned to setpoint 1.	°C/°F	rC1 = 99.0
rH0	Hot temperature regulation differential, to be added to setpoint 1 (setpoint 1 + rH0).	°C/°F	0.1...15.0

7.1.1 Operation

The controller manages the temperature on the basis of the type of request (Hot/Cold).

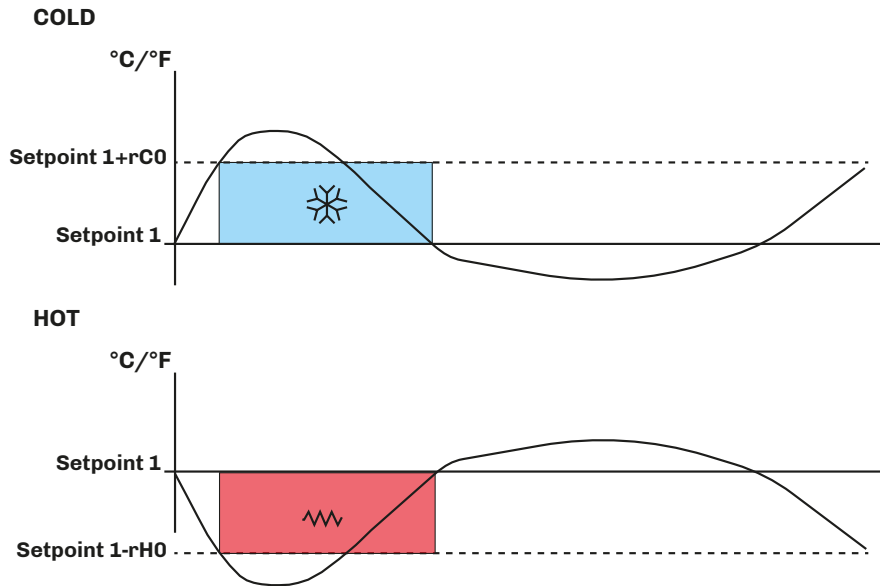

Fig. 62. Temperature regulator operation

Cold

If the controller receives a cold request:

- Cold output (compressor) between **Setpoint 1** and **Setpoint 1 + rC0**.

When the temperature read by Pb1 reaches the value of **Setpoint 1 + rC0**, the controller activates the compressor output to produce a cold effect until the temperature falls below the threshold set by **Setpoint 1**.

Hot

If the controller receives a hot request:

- Hot output (heaters) between **Setpoint 1** and **Setpoint 1 - rH0**.

When the temperature read by Pb1 reaches the value of **Setpoint 1 - rH0**, the controller activates the heater output to produce a hot effect until the temperature rises above the threshold set by **Setpoint 1**.

7.2 HOT/COLD TEMPERATURE WITH NEUTRAL ZONE

The temperature regulation configuration parameters for the neutral zone are:

Par.	Description	MU	Range
P15	Regulation type. 0 = Cold 1 = Hot; 2 = Hot/Cold/humidity with neutral zone.	---	0...2
rC0	Cold temperature regulation differential, to be added to the setpoint (setpoint 1 + rC0).	°C/°F	0.1...15.0
rC1	Minimum value that can be assigned to Setpoint 1.	°C/°F	-99.9...rC2
rC2	Maximum value that can be assigned to Setpoint 1.	°C/°F	rC1 = 99.0
rC3	Cold management neutral zone value to be added to the differential.	°C/°F	0.0...10.0
rH0	Hot temperature regulation differential, to be added to setpoint 1 (setpoint 1 + rH0).	°C/°F	0.1...15.0
rH3	Hot management neutral zone value to be added to the differential.	°C/°F	0.0...10.0

7.2.1 Operation

Regulation in the neutral zone occurs if:

- **P15** = 2;
- **rC3** > 0, for cold management;
- **rH3** > 0, for hot management;

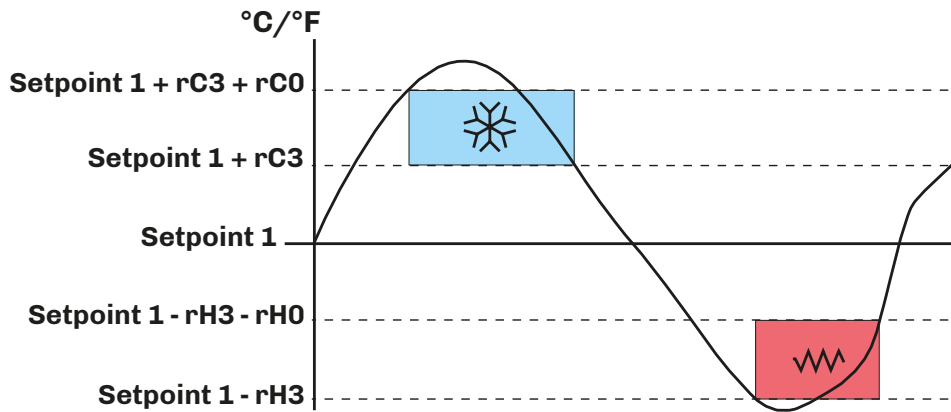

Fig. 63. Temperature regulator operation in the neutral zone

Cold

If the controller has received a cold request:

- Cold output (compressor) between **Setpoint 1 + rC3 + rC0** and **Setpoint 1 + rC3**.

When the temperature read by Pb1 reaches the value of **Setpoint 1 + rC3 + rC0**, the controller activates the compressor output until the temperature falls below the threshold set by **Setpoint 1 + rC3**.

Hot

If the controller has received a hot request:

- Hot output (heaters) between **Setpoint 1 - rH3 - rH0** and **Setpoint 1 - rH3**.

When the temperature read by Pb1 reaches the value of **Setpoint 1 - rH3 - rH0**, the controller activates the heater output to produce a hot effect until the temperature rises above the threshold set by **Setpoint 1 - rH3**.

7.3 HUMIDITY

The humidity regulation configuration parameters are:

Par.	Description	MU	Range
rU5	Dehumidification regulation differential, to be added to setpoint 2 (setpoint 2 + rU5).	% R.H.	1...100
rU8	Humidification regulation differential, to be added to setpoint 2 (setpoint 2 + rU8).	% R.H.	1...100

Humidity regulation can be managed by means of the evaporator fan or, if there is a humidity sensor, regulation can take place with a neutral zone.

7.3.1 Operation

The controller manages humidification and dehumidification requests by setting parameters **rU5** and **rU8**.

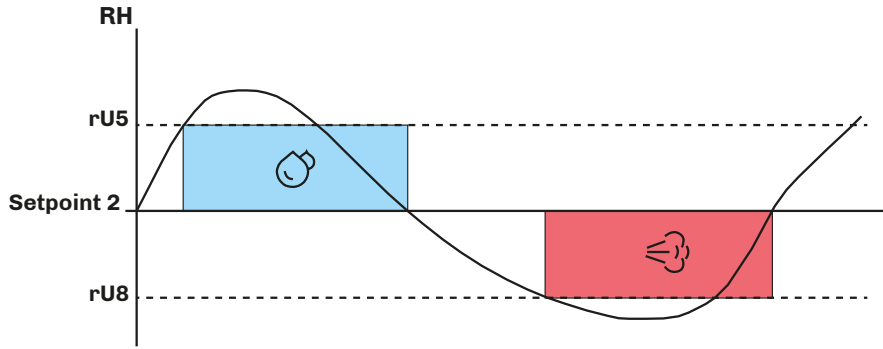

Fig. 64. Humidity regulator operation

7.4 HUMIDITY WITH NEUTRAL ZONE

The humidity regulation configuration parameters with a neutral zone are:

Par.	Description	MU	Range
rU5	Dehumidification regulation differential, to be added to setpoint 2 (setpoint 2 + rU5).	% R.H.	1...100
rU6	Dehumidification neutral zone value to be added to the differential.	% R.H.	0...100
rU8	Humidification regulation differential, to be added to setpoint 2 (setpoint 2 + rU8).	% R.H.	1...100
rU9	Humidification neutral zone value to be added to the differential.	% R.H.	0...100
rU13	Maximum value that can be assigned to Setpoint 2.	% R.H.	0...100

7.4.1 Operation

Regulation in the neutral zone occurs if:

- **P15** = 2;
- For humidification, if **rU9** ≠ 0;
- For dehumidification, if **rU6** ≠ 0;

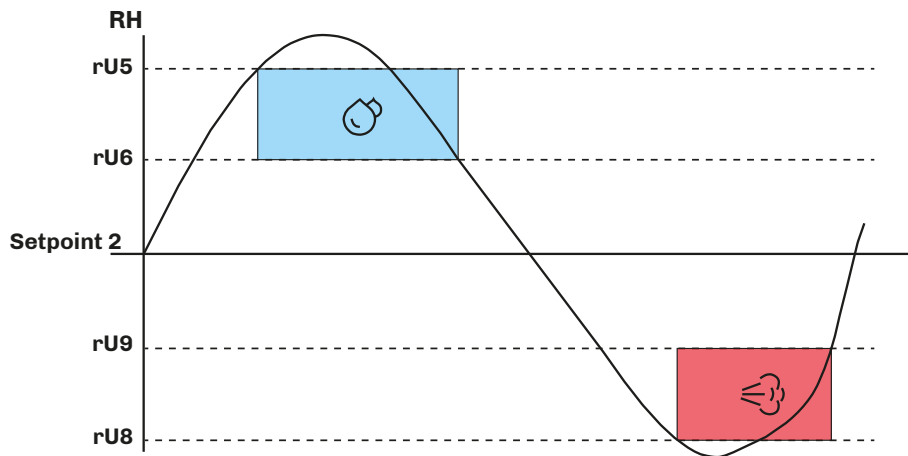

Fig. 65. Humidity regulator operation in the neutral zone

In operation with a neutral zone, values above and below the humidity setpoint (setpoint 2) are set, thereby defining the zone within which the humidification or dehumidification outputs will not be activated.

When:

- Humidity > **Setpoint 2** + **rU6** + **rU5**, then the controller activates the dehumidification output;
- Humidity < **Setpoint 2** - **rU9** - **rU8**, then the controller activates the humidification output.

7.4.2 Humidification management

Humidity management is assigned to two different outputs based on the configuration of parameter **E10**:

- Humidity generator output;
- Humidifier output.

Par.	Description	MU	Range
E10	Humidifier type. 0 = Isothermal humidifier (steam generators); 1 = Adiabatic humidifier with direct generation.	---	0/1

Isothermal humidifier

If **E10** = 0, the steam generator output remains active for the entire time period for which humidification management is set. The direct generation humidifier output is activated proportionally when the humidity value < **Setpoint 2 - rU9 - rU8**. The humidifier output activation time percentage is proportional to the humidity value in relation to the proportional band value defined by parameter **rU10**.

The humidifier output activation/deactivation time can be set via parameter **rU11**, while the activation duration is defined by parameter **rU12**.

Direct generation humidifier

If **E10** = 1, the steam generator output is only activated when:

- Humidity < **Setpoint 2 - rU9 - rU8**

Meanwhile, the humidifier output is activated in ON/OFF cycles when requested, always beginning with the OFF time so as to allow the generator to be ready to generate steam.

Par.	Description	MU	Range
SP2	Humidity Setpoint 2.	% R.H.	0... rU13
rU8	Humidification regulation differential, to be added to setpoint 2 (setpoint 2 + rU8).	% R.H.	1...100
rU9	Humidification neutral zone value to be added to the differential.	% R.H.	0...100
rU10	Humidification proportional band value.	% R.H.	0...100
rU11	Cycle time for humidification proportional regulation.	s	0...255
rU12	Time base for humidification proportional regulation cycle time. 0 = Seconds; 1 = Minutes.	---	0/1
rU13	Maximum value that can be assigned to Setpoint 2.	% R.H.	0...100

7.4.3 Dehumidification management

Dehumidification can be managed in two ways:

- If **u3** = 0, by means of an extractor fan/external dehumidifier;
- If **u3** = 1, through activation of the refrigeration system.

Dehumidification via external fan

If **u3** = 0, the output will be activated when:

- Humidity < **Setpoint 2 + rU6 + rU5**

While it is deactivated when the humidity falls within the dehumidification neutral zone values.

Dehumidification via refrigeration system

If **u3** = 1, no digital output should be configured as dehumidification.

7.5 COMPRESSOR

The compressor regulator is running when at least one relay output is configured as compressor **u1c...u9c** = 4.

Compressor switch-on/off is regulated by:

- Temperature read by the regulation probe;
- Temperature adjustment configuration;
- Defrosting and dripping.

Activation conditions

The compressor is activated automatically, if the following conditions are met:

- The controller is on (regulation is inhibited while the controller is in standby);
- Regulation probe working;
- Compressor activation delay time from switch-on **C0** elapsed;
- Compressor switch-on delay time **C2** between 2 consecutive activations;
- If **d1** = 0, 2, defrosting and dripping must be completed.

If a delay time **C0** or **C2** is set and there is a compressor activation request, the controller waits for the delay time to elapse before activating the compressor. During this wait period, the ✖ icon flashes until the compressor is activated, after which it remains lit steadily.

The compressor regulation configuration parameters are:

Par.	Description	MU	Range
C0	Compressor ON delay from power-on.	min	0...240
C1	Delay between two consecutive compressor switch-ons.	min	0...240
C2	Minimum compressor OFF time.	min	0...240
C3	Minimum compressor ON time.	s	0...240
C4	Compressor ON time in dehumidification.	min	0...240

Par.	Description	MU	Range
C6	Condensation temperature over which the condenser overheat alert is triggered.	°C/°F	0.0...164.0
C7	Condenser temperature over which the compressor lock alarm is triggered, once time period C8 has elapsed.	°C/°F	0.0...164.0
C8	Compressor lock alarm activation delay from when threshold C7 was exceeded.	min	0...15
C9	Consecutive cold room temperature time in proportional band for compressor at maximum capacity.	h	0...99
C10	Total compressor operation time for maintenance alert.	days	0...999
C11	Compressor 2 switch-on delay from compressor 1 switch-on.	s	0...999
C12	Compressor OFF time in cold room probe alarm mode.	min	0...240
C13	Compressor ON time in cold room probe alarm mode.	min	0...240

7.5.1 Operating diagrams

Normal compressor operation

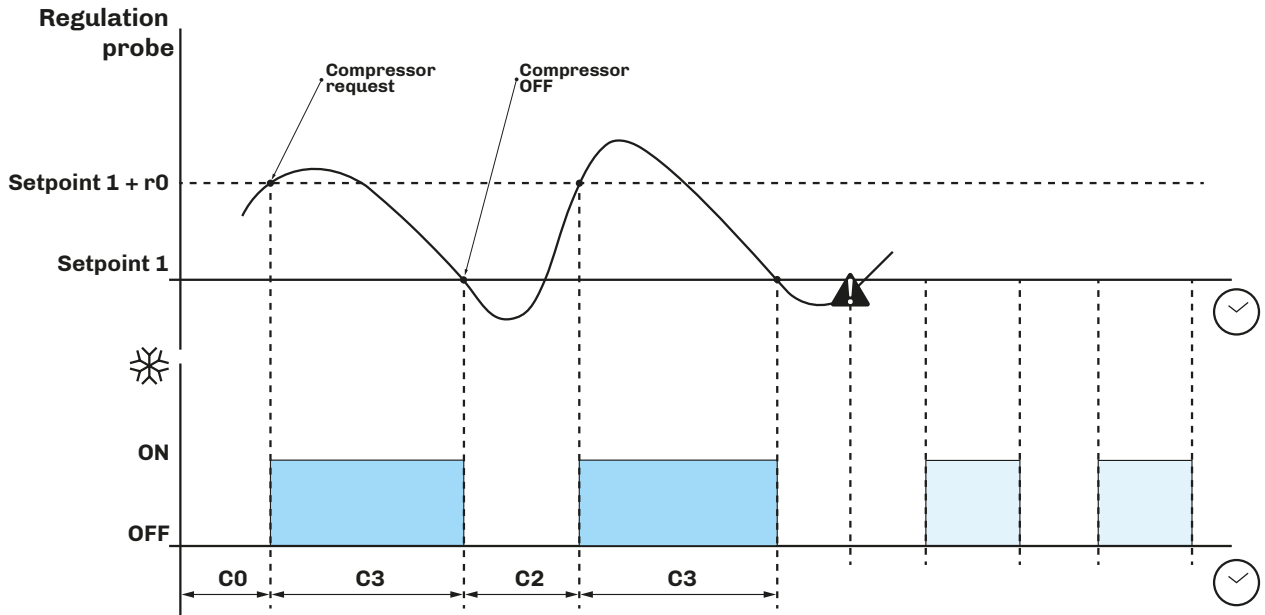

Fig. 66. Normal compressor operation

Compressor operation with probe alarm

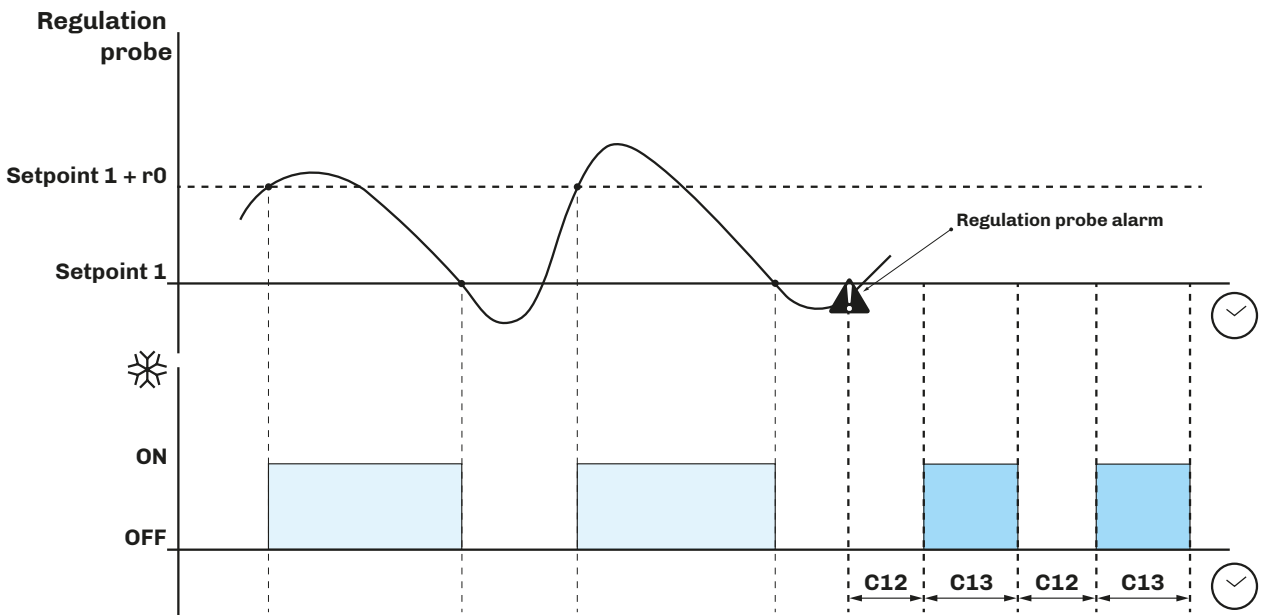

Fig. 67. Compressor operation with probe alarm

7.5.2 Variable speed compressor

A variable speed compressor provides an alternative to compressor ON/OFF operation. Models that can be used are identified by parameter **VC3**.

Regulation for this compressor is the PI type defined by parameters **VC1** and **VC2**; parameter **VC4** can be used to set for how long, at the first power-on, the compressor runs at a speed of 85 Hz, before PI regulation is taken into account.

The compressor speed can be forced to maximum if, after a time period set in parameter **C9**, the compressor is still within the proportional band.

If the cold room temperature is under **SP1 - rH0**, the compressor is switched off immediately, even if the entire time has not yet elapsed.

Par.	Description	MU	Range
VC1	Proportional band.	°C/°F	0.0...99.0
VC2	Full time action.	min	0...99
VC3	Compressor type. 1 = Embraco VEM – VES; 2 = Embraco VEG – VES; 3 = Embraco VNEK – VNEU – FMFT; 4 = Secop VNL 50...150 Hz (40 Hz in OFF); 5 = Secop 33...133 Hz; 6 = Tecumseh 85...150 Hz; 7 = Tecumseh 68...150 Hz;	---	1...7
VC4	Compressor time at 85 Hz from power-on.	s*10	0...100
VC5	Percentage for increasing the minimum compressor frequency. If VC5=0 the minimum operating frequency is the value identified by the compressor manufacturer.	%	0...100
VC6	Percentage for decreasing the compressor frequency. If VC6=100 the maximum operating frequency is the value identified by the compressor manufacturer.	%	0...100
C9	Consecutive cold room temperature time in proportional band for compressor at maximum capacity.	h	0...99

7.6 EVAPORATOR FANS

The evaporator fan regulator is activated on the basis of the following conditions:

- Delay **F3** has elapsed in the event of dripping end;
- The temperature of evaporator probe Pb2 exceeds the threshold **F1** (if **F0** = 3, 4);
- The fans are not deactivated during defrost **F2** = 0;
- Dripping **d7** is not active.

7.6.1 Regulator operation

Evaporator fan regulator activation can take place according to requests made by other regulators in the following ways:

- On the compressor's request, to encourage the production and distribution of cold temperatures (temperature control function);
- To regulate/limit hot air distribution during a defrost request;
- On the humidifying/dehumidifying regulator's request, to propagate or limit the distribution of humidity.

7.6.2 Operating modes

The evaporator fans run in accordance with parameters **F0** and **E13**:

Par.	Description	MU	Range
F0	Evaporator fans in normal operating mode. 0 = Always OFF; 1 = Always ON; 2 = Active depending on loads; 3 = Temperature-controlled (F1 relating to temperature regulation); 4 = Active depending on loads and temperature-controlled (F1 relating to temperature regulation); 5 = With ON/OFF cycles, while the compressor is off, on the basis of parameters F14 and F15 ; 6 = Thermostat-controlled based on F1 (as an absolute value); 7 = Thermostat-controlled based on F1 with the compressor on (as an absolute value); 8 = With ON/OFF cycles; in this case the humidity probe performs a read-only function and does not take part in regulation.	---	0...8
E13	Evaporator fan configuration. 0 = Fans at speed 1 (with an output u1c...u13c = 3); 1 = Fans at speed 2 (with an output u1c...u13c = 3 and u1c...u13c = 11); 2 = Fans at speed 5 via output 0...10 Vdc; 3 = Fans at speed 5 via PWM output; 4 = Fans at speed 2 with 2 relays (with an output u1c...u13c = 3 and u1c...u13c = 11).	---	0...4

Cyclical evaporator fans with F11 > 0

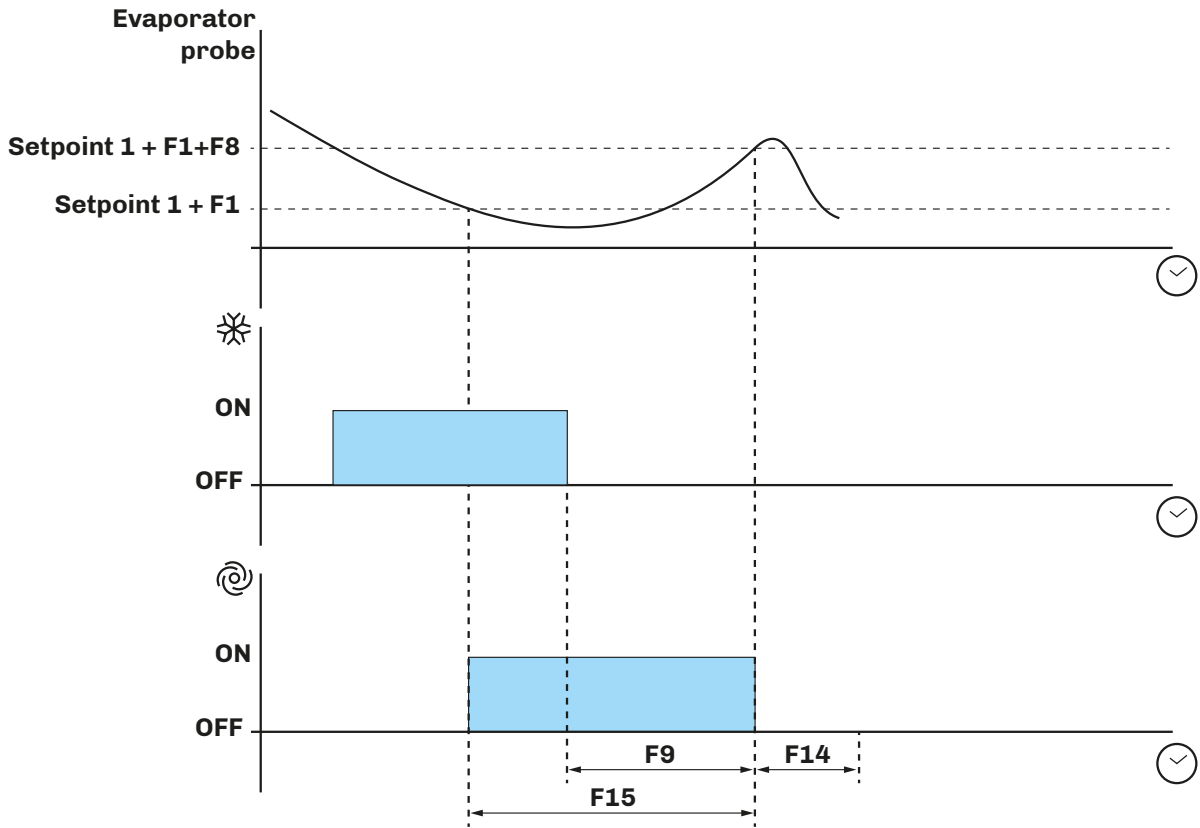

Fig. 68. Evaporator fan operation with F15 > 0

7.6.3 Operation during a defrost

Evaporator fan operation during a defrost depends on F2.

Par.	Description	MU	Range
F2	Evaporator fan mode during defrosting. 0 = OFF; 1 = ON.	---	0/1

7.6.4 Evaporator fan operation during dripping

During a dripping phase, the evaporator fans remain off for the time set in d7, plus a further delay F3 can be set for the activation of evaporator fans after dripping. In this case the fans will be activated once F3 has elapsed.

7.7 CONDENSER FANS

Fan operating mode is determined by parameter F11:

Par.	Description	MU	Range
F11	Condenser fan mode. 0 = Temperature-controlled; 1 = Temperature-controlled if compressor OFF; 2 = Temperature-controlled if compressor ON; 3 = Temperature-controlled if compressor and defrost OFF.	---	0...3

7.7.1 Operation

The condenser fans are activated on the basis of the following conditions:

- A digital output u1c...u9c = 4 or 12 (configured as condenser fans);
- If no analogue input is configured as condenser probe, the condenser fans are activated in parallel with the compressor;
- If Pr1...Pr3 = 2, and depending on F11, the condenser fans are activated when the temperature of the condenser exceeds F12 + 2 °C, while it switches off when the temperature < F12.
- During hot gas defrosting, they are activated when the condenser temperature exceeds alarm threshold C6;
- During defrosting the condenser fans switch off.

7.8 ENERGY SAVING / ECO

The energy saving function, depending on the machine configuration, offers 1 to 3 saving levels.

7.8.1 Operation

Energy saving can be activated via:

- Digital input, if **i4**, **i7**, **i10** = 8;
- Key (see "**5.9 Energy saving / Eco mode**" on page 35");
- RTC, by enabling energy saving every day, at the time **ES3** for a time period +.

Activation conditions

The conditions activating energy saving are:

- **ES4** = 0
 - Setpoint reached and door closed for at least **ES2** minutes.
 - Closure of the digital input configured as energy saving.
- **ES4** > 0
 - Energy saving mode activation scheduled time reached (**ES3**).

The conditions which disable energy saving are:

- **ES4** = 0
 - Door opening;
 - Machine power-off;
 - Disabling energy saving via the keypad;
 - Presence of a cold room high temperature alarm or a high temperature alarm.
 - If energy saving had been enabled via digital input, in addition to the conditions in the point above, it will also be disabled by the opening of the digital input or due to the time set in parameter **ES1** elapsing (if parameter **ES1**=0 only the opening of the digital input will be taken into account).
- **ES4** > 0
 - Door opening, machine switch-off, energy disabling via keypad, presence of a cold room high temperature alarm or a product high temperature alarm.
 - In addition to the aforementioned conditions, it is deactivated when the time period in **ES4** has elapsed.

NOTE: If a defrost starts during energy saving mode, the defrost has no effect on the energy saving status.

The energy saving configuration parameters are:

Par.	Description	MU	Range
ES0	Energy saving mode. 0 = 1 level (Disabled/High saving); 1 = 3 levels (Disabled/Low saving/Medium saving/High saving).	num	0/1
ES1	Maximum energy saving duration.	min	0...999
ES2	Consecutive time door closed for energy saving mode activation.	min	0...999
ES3	Energy saving mode activation scheduled time.	h	0...24
ES4	Energy saving duration.	h	0...24

The parameters for **Low saving** selection are:

Par.	Description	MU	Range
ES5	Setpoint delta corresponding to Low saving .	°C/°F	0.0...10.0
ES8	Low saving differential	°C/°F	0.0...10.0
ES11	Low saving door heater ON time.	min	0...100

The parameters for **Medium saving** selection are:

Par.	Description	MU	Range
ES6	Setpoint delta corresponding to Medium saving .	°C/°F	0.0...10.0
ES9	Medium saving differential.	°C/°F	0.0...10.0
ES12	Medium saving door heater ON time.	min	0...100

The parameters for **High saving** selection are:

Par.	Description	MU	Range
ES7	Setpoint delta corresponding to High saving .	°C/°F	0.0...10.0
ES10	High saving differential.	°C/°F	0.0...10.0
ES13	High saving door heater ON time.	min	0...100

7.9 HEATERS

During a heat request, the controller activates the output set as heaters **uc1...uc13c** = 7, in order to manage an on-off duty cycle defined by parameters **rH6** and **rH7**.

7.10 STEAM GENERATOR OUTPUT

Management of the steam generator user depends on parameter **E10**:

- If **E10=0**: the steam generator is always active when regulation requires humidification;
- If **E10=1**: the steam generator output is only active when regulation requires humidification.

7.11 HUMIDIFIER OUTPUT

Humidifier output management

The humidifier user (if enabled) can be managed with or without the use of the humidity transducer (**rU0**) and varies on the basis of the type of humidifier selected (**E10**).

7.11.1 Humidifier output management without probe or transducer

Set:

- **rU0** = 2;
- **E10** = 0 or 1.

The humidifier output remains active for a duty-cycle which varies according to the humidity setpoint selected for the phase in progress.

On/OFF duration is determined by parameters **rU2** and **rU3**.

The humidification on/off times are re-proportioned based on the percentage set for the humidity setpoint on the basis of parameter **rU3**, and will repeat every time the cycle set with **rU2** is performed.

7.11.2 Isothermal humidifier | Humidifier output management with probe or transducer

Set:

- **rU0** = 3;
- **E10** = 0.

The humidifier output is activated when the humidity value inside the cold room falls below the value of the neutral zone (**rU9**) as well as the threshold defined by the humidification differential (**rU8**).

The humidifier output activation duration is proportional to the humidity value in relation to the humidification proportional band value (**rU10**).

Parameter **rU11** defines the cycle time, while parameter **rU12** represents the time base on which the output activation duration is calculated.

7.11.3 Adiabatic humidifier | Humidifier output management with transducer

Set:

- **rU0** = 3;
- **E10** = 1.

The humidifier output is activated when the humidity value inside the cold room falls below the value of the neutral zone (**rU9**) as well as the threshold defined by the humidification differential (**rU8**), carrying out ON/OFF cycles with a duration as established by parameters **rU15** and **rU16**. The counter always begins with **OFF** time.

7.12 ALARM OUTPUT MANAGEMENT

The alarm output is activated in accordance with the value of parameter **A17** when an alarm condition is present, while it is deactivated once the alarm condition has disappeared. It is also deactivated on the basis of the configuration of parameter **u4**.

7.13 DOOR FRAME HEATER MANAGEMENT

The door frame heater, if configured, is activated when the cold room temperature falls below parameter **u5**; it is deactivated when the cold room temperature is higher than **u5+rC0**.

7.14 STANDBY/ON OUTPUT MANAGEMENT

This output is independent of any regulation; it is activated when the controller is ON and is deactivated when the controller is in STANDBY.

7.15 COLD ROOM LIGHT MANAGEMENT

This output is activated/deactivated on the basis of the door switch status and/or selection of the light key.

If the light is off, opening and closing the door will activate/deactivate the relevant output.

If the light has been switched on using a key, opening/closing the door will have no effect on the light (the light remains on until it is switched off using the key).

7.16 DOOR LOCK MANAGEMENT

This output, if configured, manages the activation and deactivation of the door lock.

7.17 WATER FILLING MANAGEMENT

Set the following to configure and enable the water filling output:

- One digital output **u1c...u13c** = 19;
- One digital input **i4, i7, i10** = 5.

The output remains active until the input is deactivated or the timeout **u12** elapses. In this case, the water filling alarm indication is given (see "**9.1 Vcolor 229/249 M/L alarm table**" on page 79).

8. PARAMETERS

Description of columns in the Table of Parameters

- **Par.:** List of configurable device parameters;
- **Description:** Indicates parameter operation and any possible selections;
- **MU:** Measurement unit relating to the parameter;
- **Range:** Describes the interval of values that the parameter can assume. This can be correlated with other instrument parameters (indicated with the parameter code).
NOTE: if the actual value is outside the permitted limits for that parameter (for example, because other parameters defining the aforementioned limits have been altered), the value of the violated limit is displayed instead of the actual value;
- **Default:** Indicates the pre-set factory configuration;

8.1 TABLE OF CONFIGURATION PARAMETERS

Par.	Description	MU	Range	Default
ANALOGUE INPUT group				
SP1	Temperature Setpoint 1.	°C/°F	-99.9... 99.9	2.0
SP2	Humidity Setpoint 2. (* with manual recipe: 0...ru13 with pre-set recipe: data limits for individual recipes with F0 = 8: 40...90	% R.H.	Variable(*)	50
CA1	Probe Pb1 offset.	°C/°F	-25.0...25.0	0.0
CA2	Probe Pb2 offset.	°C/°F	-25.0...25.0	0.0
CA3	Probe Pb3 offset.	°C/°F	-25.0...25.0	0.0
CA4	Backup module probe offset.	°C/°F	-25.0...25.0	0.0
CA5	Probe Pb5 (humidity) offset.	% R.H.	-20...20	0.0
P0	Probe type. 0 = PTC; 1 = NTC; 2 = Pt1000.	---	0...2	1
P1	Enable decimal point in °C. 0 = No; 1 = Yes.	---	0/1	1
P2	Temperature unit of measure (changing value means that the temperature parameter limits will need to be reset manually). 0 = °C; 1 = °F.	---	0/1	0
P3	Power failure duration for PF (power failure) alarm logging. -1 = Alarm disabled.	min	-1...240	15
P6	Regulation probe selection. 0 = Cold room probe; 1 = Product probe.	---	0/1	0
P7	Humidity lower limit.	% R.H.	0...100	0
P8	Humidity upper limit.	% R.H.	0...100	100
P12	Humidity probe type. 0 = Disabled; 1 = Probe 4...20 mA; 2 = EVHTP500; 3 = EVHTP520.	---	0...3	0
P13	Temperature-humidity setpoint lock. 0 = No; 1 = Yes.	---	0/1	0
P14	Differential position. 0 = Asymmetrical; 1 = Symmetrical.	---	0/1	0
P15	Regulation type. 0 = Cold 1 = Hot; 2 = Hot/Cold with neutral zone.	---	0...2	0
Pr1	Probe Pb1 configuration. 0 = Cold room; 1 = Evaporator; 2 = Condenser; 3 = Product probe; 4 = Disabled.	---	0...4	0
Pr2	Probe Pb2 configuration. Same as Pr1.	---	0...4	1
Pr3	Probe Pb3 configuration. Same as Pr1.	---	0...4	4
Pr4	Backup module probe configuration. Same as Pr1.	---	0...4	4
COLD MANAGEMENT group				
rC0	Cold temperature regulation differential, to be added to setpoint 1 (setpoint 1 + r0).	°C/°F	0.1...15.0	2.0

Par.	Description	MU	Range	Default
rC1	Minimum value that can be assigned to setpoint 1.	°C/°F	-99.9...rC2	-2.0
rC2	Maximum value that can be assigned to setpoint 1.	°C/°F	rC1 = 99.0	8.0
rC3	Neutral zone for cold management.	°C/°F	0.0...10.0	0.0
rC4	Continuous timed cycle duration.	min	0...720	30
rC5	Cooling setpoint offset.	°C/°F	rC1 = 99.0	0.0
rC6	Proportional band.	min	0...240	60
HOT MANAGEMENT group				
rH0	Hot temperature regulation differential, to be added to setpoint 1 (setpoint 1 + rH0).	°C/°F	0.1...15.0	2.0
rH3	Hot management neutral zone value to be added to the differential.	°C/°F	0.0...10.0	0.0
rH6	Cycle time for heater switch-on in the event of a hot request.	s	1...600	60
rH7	Heaters ON time during cycle rH6.	s	1...600	30
HUMIDITY group				
rU0	Humidity management mode. 0 = No regulation (probe value is shown only if P12≠0). 1 = Regulation with evaporator fan (on the basis of parameter configuration F0=5 or F0=8). If F0=5 the display will show the value read by the humidity probe only if P12≠0, while if P12=0 nothing will be displayed. If F0=8 the display will show both the value read by the humidity probe only if P12≠0, and the humidity setpoint. If P12=0 the probe value will be the same value set in the setpoint. 2 = Regulation (with setpoint) with timed cyclical humidification (rU2, rU3) on the basis of the set percentage; in this case the humidity value and the setpoint coincide (in practice the humidity value corresponds to the setpoint). If P12≠0 the probe is not displayed in any case. 3 = Regulation (with setpoint) with humidification, dehumidification and heating; in this case there must be a humidity probe, and the probe value and setpoint are shown on the display.	---	0...3	0
rU1	Minimum temperature in the cold room for inhibiting humidification control.	°C/°F	-99.0...99.0	0.0
rU2	Cycle time for switching on the humidifier (rU0 = 2 only).	s	1...600	60
rU3	Humidifier on time within the cycle time rU2 to generate 100% humidity in the cold room (rU0 = 2 only)	s	1...600	30
rU5	Dehumidification regulation differential, to be added to setpoint 2 (setpoint 2 + rU5).	% R.H.	1...100	5
rU6	Neutral zone for dehumidification regulation.	% R.H.	1...100	2
rU8	Humidification regulation differential, to be added to setpoint 2 (setpoint 2 + rU8).	% R.H.	1...100	5
rU9	Neutral zone for humidification regulation.	% R.H.	1...100	2
rU10	Humidification proportional band value.	% R.H.	0...100	10
rU11	Cycle time for humidification proportional regulation.	s	0...255	30
rU12	Time base for humidification proportional regulation cycle time. 0 = Seconds; 1 = Minutes.	---	0/1	0
rU13	Maximum value that can be assigned to Setpoint 2.	% R.H.	0...100	80
rU14	Minimum temperature in the cold room for inhibiting dehumidification.	°C/°F	-99.0...99.0	0
rU15	Humidifier pause time.	s	0...300	60
rU16	Humidifier activation time.	s	0...60	3
rU17	Heater activation if running dehumidification with compressor. 0 = Deactivated; 1 = Activated.	---	0/1	1
COMPRESSOR group				
C0	Compressor ON delay from power-on.	min	0...240	0
C1	Delay between two consecutive compressor switch-ons.	min	0...240	3
C2	Minimum compressor OFF time.	min	0...240	3
C3	Minimum compressor ON time.	s	0...240	0
C4	Compressor ON time in dehumidification.	min	0...240	0
C6	Condensation temperature over which the condenser overheat alert is triggered.	°C/°F	0.0...164.0	70.0
C7	Condenser temperature over which the compressor lock alarm is triggered, once time period C8 has elapsed.	°C/°F	0.0...164.0	80.0

Par.	Description	MU	Range	Default
C8	Compressor lock alarm activation delay from when threshold C7 was exceeded.	min	0...15	1
C9	Consecutive cold room temperature time in proportional band for compressor at maximum capacity.	h	0...99	5
C10	Total compressor operation time for maintenance alert.	days	0...999	0
C11	Compressor 2 switch-on delay from compressor 1 switch-on.	s	0...999	3
C12	Compressor OFF time in cold room probe alarm mode.	min	0...240	10
C13	Compressor ON time in cold room probe alarm mode.	min	0...240	10
VARIABLE SPEED COMPRESSOR group				
VC1	Proportional band.	°C/°F	0.0...99.0	10.0
VC2	Full time action.	min	0...99	10
VC3	Compressor type. 1 = Embraco VEM – VES; 2 = Embraco VEG – VES; 3 = Embraco VNEK – VNEU – FMFT; 4 = Secop VNL 50...150 Hz (40 Hz in OFF); 5 = Secop 33...133 Hz; 6 = Tecumseh 85...150 Hz; 7 = Tecumseh 68...150 Hz.	---	0...7	3
VC4	Compressor time at 85 Hz from power-on.	s x 10	0...100	0
VC5	Percentage for increasing the minimum compressor frequency. If VC5 =0 the minimum operating frequency is the value identified by the compressor manufacturer.	%	0...100	0
VC6	Percentage for decreasing the compressor frequency. If VC6 =100 the maximum operating frequency is the value identified by the compressor manufacturer.	%	0...100	100
DEFROST group				
d0	Automatic defrost interval.	h	0...99	8
d1	Defrost type. 0 = Electric heaters; 1 = Cycle inversion (hot gas); 2 = On compressor stoppage.	---	0...2	0
d2	Evaporator temperature over which defrost ends with evaporator probe (Pr1...Pr3 = 1).	°C/°F	-99.0...99.0	8.0
d3	Defrost duration.	min	0...99	30
d4	Enable defrost at device switch-on. 0 = No; 1 = Yes, activate defrost at switch-on.	---	0/1	0
d5	Defrost delay after power failure (if d4 = 1).	min	0...99	0
d6	Value shown on the display during a defrost. 0 = Regulation; 1 = Display locked; 2 = Defrosting in progress text.	---	0...2	2
d7	Evaporator drip time after a defrost.	min	0...15	2
d8	Automatic defrost interval count mode. 0 = Device ON hours; 1 = Compressor ON hours; 2 = Evaporator temperature < d9 ; 3 = Adaptive; 4 = Manual defrost.	---	0...4	0
d9	Evaporator threshold for counting the automatic defrost interval d8 = 2.	°C/°F	-99.0...99.0	0.0
d11	Enable alert for defrost end due to maximum duration (code dFd). 0 = No; 1 = Yes.	---	0/1	0
d15	Compressor ON time before hot gas defrost.	min	0...99	0
d16	Pre-dripping time.	min	0...99	0
d18	Adaptive defrost interval.	min	0...999	40
d19	Temperature for starting adaptive defrost.	°C/°F	0.0...40.0	3.0
d20	Consecutive compressor ON time for defrost. 0 = Disabled.	min	0...999	0
d21	Consecutive compressor ON time for defrost from power-on and from cooling.	min	0...500	0

Par.	Description	MU	Range	Default
d22	Adaptive defrost interval count suspension temperature.	°C/°F	-10.0...10.0	-2.0
d23	Number of door openings for defrost.	num	0...240	0
d24	Consecutive time door open for defrost.	min	0...240	0
d00	Enable mode B defrost parameters on setpoint threshold. 0 = No; 1 = Yes.	---	0/1	0
d01	Setpoint threshold for mode B parameter activation.	°C/°F	-99.0...99.0	1.0
d0b	Mode B automatic defrost interval.	min	0...240	6
d1b	Mode B defrost type. 0 = Electric heaters; 1 = Cycle inversion (hot gas); 2 = On compressor stoppage.	---	0...2	2
d2b	Mode B defrost end threshold.	°C/°F	-99.0...99.0	4.0
d3b	Mode B defrost duration.	min	0...99	20
d7b	Mode B dripping time.	min	0...15	0
ALARMS group				
A1	High/low power-on temperature alarm delay.	min	0...240	120
A2	High/low defrost temperature alarm delay.	min	0...240	15
A3	High/low temperature alarm delay from door closure.	min	0...240	15
A5	Cold room alarm type. 0 = Corresponding SET; 1 = Absolute.	---	0/1	1
A6	Cold room alarm delay.	s	0...900	60
A7	Cold room alarm hysteresis.	°C/°F	0.0...20.0	2.0
A8	LOW cold room temperature alarm threshold.	°C/°F	-99.0...99.0	-50.0
A9	HIGH cold room temperature alarm threshold.	°C/°F	-99.0...99.0	50.0
A10	Alarm delta for LOW cold room temperature in relation to the setpoint.	°C/°F	-50.0...0.0	-3.0
A11	Alarm delta for HIGH cold room temperature in relation to the setpoint.	°C/°F	0.0...50.0	4.0
A12	LOW cold room temperature PRE-alarm threshold.	°C/°F	-99.0...99.0	-50.0
A13	HIGH cold room temperature PRE-alarm threshold.	°C/°F	-99.0...99.0	50.0
A14	PRE-alarm delta for LOW cold room temperature in relation to the setpoint.	°C/°F	-50.0...0.0	-3.0
A15	PRE-alarm delta for HIGH cabinet temperature in relation to the setpoint.	°C/°F	0.0...50.0	4.0
A5b	Product alarm type. 0 = Corresponding SET; 1 = Absolute.	---	0/1	1
A6b	Product alarm delay.	s	0...900	60
A7b	Product alarm hysteresis.	°C/°F	0.0...20.0	2.0
A8b	LOW product temperature alarm threshold.	°C/°F	-99.0...99.0	-50.0
A9b	HIGH product temperature alarm threshold.	°C/°F	-99.0...99.0	50.0
A10b	Alarm delta for LOW product temperature in relation to the setpoint.	°C/°F	-50.0...0.0	-3.0
A11b	Alarm delta for HIGH product temperature in relation to the setpoint.	°C/°F	0.0...50.0	4.0
A12b	LOW product temperature PRE-alarm threshold.	°C/°F	-99.0...99.0	-50.0
A13b	HIGH product temperature PRE-alarm threshold.	°C/°F	-99.0...99.0	50.0
A14b	PRE-alarm delta for LOW product temperature in relation to the setpoint.	°C/°F	-50.0...0.0	-3.0
A15b	PRE-alarm delta for HIGH product temperature in relation to the setpoint.	°C/°F	0.0...50.0	4.0
A16	Buzzer reactivation time in alarm.	s	0...900	300
A17	Alarm output activation 0 = with alarm active; 1 = with alarm inactive.	---	0/1	0

Par.	Description	MU	Range	Default
A18	Evaporator temperature threshold for high temperature alarm.	°C/°F	0.0...99.0	70.0
A19	Evaporator high temperature alarm delay. -1 = Disabled.	min	-1...240	-1
EVAPORATOR/CONDENSER FAN group				
F0	Evaporator fans in normal operating mode. 0 = Always OFF; 1 = Always ON; 2 = Active depending on loads; 3 = Temperature-controlled (F1 relating to temperature regulation); 4 = Active depending on loads and temperature-controlled (F1 relating to temperature regulation); 5 = With ON/OFF cycles, while the compressor is off, on the basis of parameters F14 and F15 ; 6 = Thermostat-controlled based on F1 (as an absolute value); 7 = Thermostat-controlled based on F1 with the compressor on (as an absolute value); 8 = With ON/OFF cycles; in this case the humidity probe performs a read-only function and does not take part in regulation.	---	0...8	1
F1	Evaporator fan regulation threshold with F0 = 3, 4 (relative to the setpoint).	°C/°F	-99.0...99.0	-4.0
F2	Evaporator fan mode during defrosting. 0 = OFF; 1 = ON.	---	0/1	0
F3	Maximum evaporator fan post-dripping stoppage time.	min	0...15	2
F4	Fan OFF time in energy saving mode.	S x 10	0...240	30
F5	Fan ON time in energy saving mode.	S x 10	0...240	30
F6	Fan speed forcing during energy saving mode.	%	0...100	0
F7	Threshold relative to the setpoint for fan restart after a defrost.	°C/°F	-99.0...99.0	5.0
F8	Evaporator setpoint differential.	°C/°F	1.0...15.0	2.0
F9	Evaporator fan switch-off delay from compressor switch-off.	s	0...240	0
F10	Fan speed forcing during dehumidification.	%	0...100	0
F11	Condenser fan mode. 0 = Temperature-controlled; 1 = Temperature-controlled if compressor OFF; 2 = Temperature-controlled if compressor ON; 3 = Temperature-controlled if compressor and defrost OFF.	---	0...3	2
F12	Condenser fan setpoint.	°C/°F	-0.0...99.0	15.0
F13	Condenser fan switch-off delay from compressor switch-off.	s	0...240	0
F14	Fan OFF time in the absence of regulation with F0 = 5. F14 = 0 and F15 > 0 fans are always on.	s x 10	0...240	60
F15	Fan ON time in the absence of regulation with F0 = 5. F15 = 0 fans remain stopped.	s x 10	0...240	10
F16	Evaporator fan switch-on delay from door closure.	s	0...240	0
F19	Evaporator minimum speed.	%	0...100	20
F20	Evaporator maximum speed.	%	0...100	100
F21	Evaporator fan boost speed.	%	0...100	75
F22	Boost time at evaporator fan switch-on.	s	0...240	5
F23	Evaporator fan minimum calibration speed value.	%	0...100	35
F24	Evaporator fan maximum calibration speed value.	%	0...100	65
F25	Speed value 1.	%	0...100	20
F26	Speed value 2.	%	0...100	40
F27	Speed value 3.	%	0...100	60
F28	Speed value 4.	%	0...100	80
F29	Speed value 5.	%	0...100	100
F30	Differential for activation of the second condenser fan.	°C/°F	-0.0...99.0	0.0
F0b	Evaporator fan mode in mode B normal operation. Same as F0 .	---	0...8	1
F2b	Evaporator fan mode in mode B defrost. Same as F2 .	---	0/1	0
F3b	Maximum evaporator fan post-dripping stoppage time, mode B.	min	0...15	2

Par.	Description	MU	Range	Default
ENERGY SAVING group				
ES0	Energy saving mode. 0 = 1 level (Disabled/High saving); 1 = 3 levels (Disabled/Low saving/Medium saving/High saving).	num	0/1	0
ES1	Maximum energy saving duration.	min	0...999	0
ES2	Consecutive time door closed for energy saving mode activation.	min	0...999	10
ES3	Energy saving mode activation scheduled time.	h	0...24	24
ES4	Energy saving duration.	h	0...24	0
ES5	Setpoint delta corresponding to Low saving .	°C/°F	0.0...10.0	0.5
ES6	Setpoint delta corresponding to Medium saving .	°C/°F	0.0...10.0	1.0
ES7	Setpoint delta corresponding to High saving .	°C/°F	0.0...10.0	1.5
ES8	Low saving differential.	°C/°F	0.0...10.0	0.4
ES9	Medium saving differential.	°C/°F	0.0...10.0	0.8
ES10	High saving differential.	°C/°F	0.0...10.0	1.2
ES11	Low saving door heater ON time.	min	0...100	8
ES12	Medium saving door heater ON time.	min	0...100	6
ES13	High saving door heater ON time.	min	0...100	4
ES14	OFF time after ES11, ES12, ES13 .	min	0...60	2
ES15	Period of time for calculating/updating compressor work percentage.	min	0...240	0
ES16	Reserved.	---	---	0
ES17	Light status during Energy saving. 0 = The light remains in its current status; 1 = If lit, the light is switched off (in any case the light can always be switched on/off using the key).	---	0/1	0
SANITISING group				
SA0	Sanitising type. 0 = Disabled. 1 = UV lamp; 2 = Ozone generator.	---	0...2	0
SA1	Cold room temperature below which the sanitising cycle, if started, is paused.	°C/°F	99.0...99.0	0.0
SA2	Sanitising cycle duration.	min	0...240	10
SA3	Delay after Sanitising.	min	0...240	5
THAWING group				
th01	Initial cold room temperature setpoint for low-load thawing.	°C/°F	-50.0...99.0	25.0
th02	Initial cold room temperature setpoint for medium-load thawing.	°C/°F	-50.0...99.0	30.0
th03	Initial cold room temperature setpoint for high-load thawing.	°C/°F	-50.0...99.0	35.0
th04	Final cold room temperature setpoint for low-load thawing.	°C/°F	-50.0...99.0	10.0
th05	Final cold room temperature setpoint for medium-load thawing.	°C/°F	-50.0...99.0	12.0
th06	Final cold room temperature setpoint for high-load thawing.	°C/°F	-50.0...99.0	15.0
th07	Low-load thawing duration.	min	1...999	240
th08	Medium-load thawing duration.	min	1...999	480
th09	High-load thawing duration.	min	1...999	720
th10	Post-thawing cold room storage temperature setpoint (cold only).	°C/°F	-50.0...99.0	3.0
th11	Fan speed during first thawing phase.	---	1...5	1
th12	Fan speed during second thawing phase.	---	1...5	1
th13	Fan speed during third thawing phase.	---	1...5	1
th14	Fan speed during fourth thawing phase.	---	1...5	1
th15	Fan speed during fifth thawing phase.	---	1...5	1
th16	Fan speed for thawing storage.	---	1...5	1
th17	Thawing neutral zone corresponding threshold.	°C/°F	0.0...10.0	1.0
th18	Cold room setpoint differential during thawing, heater activation.	°C/°F	1.0...15.0	2.0
th19	Cold room setpoint differential in thawing, compressor activation.	°C/°F	1.0...15.0	2.0
th20	Thawing heater cycle time.	s	1...600	60

Par.	Description	MU	Range	Default
tH21	Heater ON time in thawing.	s	1...600	30
tH22	Neutral zone threshold in storage phase.	°C/°F	0.0...10.0	1.0
tH23	Enable thawing cycle. 0 = Disabled; 1 = Enabled. (If TH23=0, the key is not shown on the display).	---	0/1	0
DIGITAL INPUT PROPERTIES group				
i0	Door open effect. 0 = No effect; 1 = Compressor, evaporator fan OFF (no effect on the light); 2 = Evaporator fan OFF (no effect on the compressor or light); 3 = Light only ON; 4 = Compressor, evaporator fan OFF, cold room light ON; 5 = Evaporator fan OFF, cold room light ON; 6 = Evaporator fan OFF, cold room light OFF;	---	0...6	5
i1	Door input polarity. 0 = Closed contact (NC); 1 = Open contact (NO).	---	0/1	0
i2	Door alarm delay. -1 = The alarm is not indicated.	min	-1...120	5
i3	Inhibit compressor regulation and door opening fans. -1 = Disabled.	min	-1...120	15
i4	Digital input 1 effect. 0 = Disabled; 1 = Compressor 1 high pressure alarm; 2 = Compressor 2 high pressure alarm; 3 = Compressor 1 low pressure alarm; 4 = Compressor 2 low pressure alarm; 5 = Compressor 1 thermal switch alarm; 6 = Compressor 2 thermal switch alarm; 7 = System protection alarm (all loads are switched off); 8 = ECO/Energy saving activation (High saving); 9 = "iA" generic alarm (display only); 10 = Device switch-on/off; 11 = Fan thermal switch alarm.	---	0...11	0
i5	Digital input 1 polarity. 0 = Closed contact (NC); 1 = Open contact (NO).	---	0/1	0
i6	Digital input 1 alarm indication delay. -1 = The alarm is not indicated.	s	-1...120	5
i7	Digital input 2 effect. Same as i4.	---	0...11	0
i8	Digital input 2 polarity. 0 = Closed contact (NC); 1 = Open contact (NO).	---	0/1	0
i9	Digital input 2 alarm indication delay. -1 = The alarm is not indicated.	s	-1...120	5
i10	Digital input 3 effect. Same as i4.	---	0...11	0
i11	Digital input 3 polarity. 0 = Closed contact (NC); 1 = Open contact (NO).	---	0/1	0
i12	Digital input 3 alarm indication delay. -1 = The alarm is not indicated.	s	-1...120	5
i13	RESERVED.	---	---	---
i14	Light off timeout from door switch.	S x 10	0...240	30
DIGITAL OUTPUT CONFIGURATION group				
u0	Door lock present. 0 = No; 1 = Yes.	---	0/1	0
u1	RESERVED.	---	---	0

Par.	Description	MU	Range	Default
u2	Enable light key. 0 = Disabled; 1 = Enabled. NOTE: if u2=0 and the light relay is configured, this is managed by the door switch.	---	0/1	1
u3	Dehumidification management. 0 = By means of external dehumidifier/extractor fan (in this case parameters rU5 and rU6 will become meaningful); 1 = Through activation of the refrigeration system.	---	0/1	1
u4	Alarm output deactivation on buzzer silencing. 0 = Disabled; 1 = Enabled.	---	0/1	1
u5	Door heater activation temperature.	°C/°F	-99.0...99.0	-5.0
u6	Door lock polarity. 0 = Closed contact (NC); 1 = Open contact (NO).	---	0/1	0
u7	Enable alarm buzzer. 0 = Disabled; 1 = Enabled.	---	0/1	1
u8	CO2 backup alarm delay.	min	0...1440	300
u9	CO2 backup activation threshold.	°C/°F	-99.0...99.0	10.0
u10	CO2 backup differential.	°C/°F	1.0...15.0	2.0
u11	Dripping heater.	min	0...240	0
u12	Water fill timeout.	sec	0...999	60
u1c	Configure out1 relay output. 0 = Disabled; 1 = Compressor 1; 2 = Compressor 2; 3 = Evaporator fans (maximum speed); 4 = Condenser 1 fan; 5 = Defrost; 6 = Light; 7 = Door heater; 8 = Alarm; 9 = Door closure; 10 = ON/OFF; 11 = Evaporator fans (minimum speed); 12 = Condenser 2 fan; 13 = Sanitising; 14 = Heaters; 15 = Steam generator (boiler); 16 = Steam injection; 17 = Dehumidifier; 18 = Dripping heater; 19 = Water filling.	---	0...19	1
u2c	Configure out2 relay output. Same as uc1 .	---	0...18	6
u3c	Configure out3 relay output. Same as uc1 .	---	0...18	4
u4c	Configure out4 relay output. Same as uc1 .	---	0...18	3
u5c	Configure out5 relay output. Same as uc1 .	---	0...18	8
u6c	Configure out6 relay output. Same as uc1 .	---	0...18	5
u7c	Configure out7 relay output. Same as uc1 .	---	0...18	14
u8c	Configure out8 relay output. Same as uc1 .	---	0...18	7
u9c	Configure out9 relay output. Same as uc1 .	---	0...18	13
u10c	Configure out10 relay output. Same as uc1 . (Only with expansion device).	---	0...18	15
u11c	Configure out11 relay output. Same as uc1 . (Only with expansion device).	---	0...18	16
u12c	Configure out12 relay output. Same as uc1 . (Only with expansion device).	---	0...18	0
u13c	Configure out13 relay output. Same as uc1 . (Only with expansion device).	---	0...18	17

Par.	Description	MU	Range	Default
u14c	Configure out14 relay output. Same as uc1 . (Backup module). 0 = Disabled; 1 = Power failure alarm; 2 = CO2 backup alarm; 3 = Safety thermostat alarm; 4 = Frost protection alarm.	---	0...4	0
AUTOMATIC TEST group				
T1	Cold room temperature threshold for Test Cycle - Cooling Phase.	°C/°F	-99.0...99.0	20.0
T2	Cooling phase end setpoint.	°C/°F	-99.0...99.0	2.0
T3	Thermostat control phase setpoint.	°C/°F	-99.0...99.0	3.0
T4	Thermostat control phase differential.	°C/°F	1.0...15.0	3.0
T5	Number of compressor cycles, Thermostat control phase - Recovery phase.	num	1...20	2
T6	Recovery phase setpoint - Cycle Stop.	°C/°F	-99.0...99.0	2.0
T7	Maximum time for Cooling phase execution.	min	1...240	15
SERIAL COMMUNICATION group				
L1	Internal data sampling time.	min	1...60	15
LA	Modbus protocol controller address.	---	0...247	247
Lb	Modbus transmission speed (baud rate). 0 = 2400; 1 = 4800; 2 = 9600; 3 = 19200.	baud	0...3	3
LP	Modbus parity bit. 0 = None; 1 = Odd; 2 = Even.	---	0...2	2
PA1	EVlink/EVconnect user password (not via instrument).	---	-99... 999	426
PA2	EVlink/EVconnect password service.	---	-99... 999	824
BLE	Communication type. 0 = Free; 1 = Forced for EPOCA (do not change parameters LA , Lb and LP); 2...99 = Address for EPOCA local network.	---	0...99	0
GENERAL CONFIGURATION group				
E8	Inactivity time for screensaver.	min	0...240	0
E10	Humidifier type. 0 = Isothermal humidifier (steam generators); 1 = Direct generation adiabatic humidifier.	---	0/1	0
E13	Evaporator fan configuration. 0 = Fans at speed 1 (with an output u1c...u13c = 3); 1 = Fans at speed 2 (with an output u1c...u13c = 3 and u1c...u13c = 11); 2 = Fans at speed 5 via output 0...10 Vdc; 3 = Fans at speed 5 via PWM output; 4 = Fans at speed 2 with 2 relays (with an output u1c...u13c = 3 and u1c...u13c = 11).	---	0...4	0
E14	Configuration of output 0...10 V. 0 = Disabled; 1 = Evaporator fan (E13 =2); 2 = Variable speed compressor (parameter VC3).	---	0...2	0
E18	Enable users. 0 = Disabled; 1 = Enabled.	---	0/1	0
E19	Enable additional modules. 0 = None; 1 = Expansion module only; 2 = Backup module only; 3 = Expansion + backup module.	---	0...3	0
E20	Minimum battery voltage.	V	8.0...12.0	9.5
E21	Display brightness percentage.	%	10...100	60
E22	Display brightness timeout.	sec	1...300	60
E23	Inverter enable. 0 = Disabled; 1 = Enabled	---	0/1	0

Par.	Description	MU	Range	Default
HUMIDIFIER group				
HS1	Minimum humidity setpoint value. With CFG = 2, 3, 4, 7, 8, 9.	%	0...100	0
HS2	Maximum humidity setpoint value. With CFG = 2, 3, 4, 7, 8, 9.	%	0...100	95
HS3	Minimum delay time between two consecutive humidity production activations. With CFG ≠ 10.	s	1...240	20
HS4	Fan speed. 0 = Fan off; 1 = 30%; 2 = 60%; 3 = 80%.	---	0...3	2
HS5	Water conductivity.	μS*cm	70...1250	500
HS6	Number of continuous idle hours causing the water reservoir to empty. 0 = Function disabled.	h	0...250	12
HS7	Number of operating hours causing the water reservoir to empty. 0 = Function disabled.	h	0...250	24
INVERTER Group				
S202	Acceleration ramp. Time required to reach the nominal speed from 0 rpm/s.	rmp/s	1 ... 1000	30
S203	Deceleration ramp. Time required to reach 0 rpm/s from the nominal speed.	rmp/s	1 ... 1000	50
S204	Maximum motor speed ⁽¹⁾ .	rpm	S205 ... 8000	1500
S205	Minimum motor speed ⁽¹⁾ .	rpm	150 ... S204	300
S206	Select the motor rotation direction ⁽²⁾ . 0 = Clockwise; 1 = Anticlockwise.	-	0 / 1	0
S403	Time limit beyond which, if communication is not working, the device enters timeout alarm mode. 0 = Disabled.	s	0.0 ... 60.0	50.0
S501	Nominal motor current.	A	0.1 ... S601	29.0
S502	Nominal motor voltage.	V	50 ... 400	230
S503	Nominal motor frequency.	Hz	10 ... 400	50
S504	Number of motor pole pairs.	-	1 ... 8	2
S506	Nominal motor revolutions ⁽³⁾ .	rpm	1 ... 8000	1690
S508	Cos(phi). Nominal motor power factor ⁽³⁾ .	-	0.01 ... 1.00	1.00
S509	Motor boost. Overvoltage percentage applied at motor start-up.	%	0 ... 25	5
S511	Motor overload. Motor overload percentage permitted by the inverter for a time set using parameter S512 .	%	0 ... 50	50
S512	Maximum motor overload time.	s	0 ... 60	30
S529	Selection of PWM carrier frequency.	kHz	4 ... 8	5

NOTE: Changing the parameters causes the controller to restart.

9. DIAGNOSTICS

The table below lists alarms with corresponding solutions. Indication occurs through the buzzer sounding and the alarm appearing on the display. Each alarm is recorded in the Alarms menu.

9.1 VCOLOR 229/249 M/L ALARM TABLE

Description	Cause	Effects	Solution
Cold room probe alarm	<ul style="list-style-type: none"> Probe not working Probe not connected properly Incorrect probe type 	<ul style="list-style-type: none"> Alarm shown on display If regulation is set to cold room probe, regulation switches to product probe, if configured and they affect the regulators; otherwise: <ul style="list-style-type: none"> The compressor performs ON/OFF cycles Door heater OFF Heaters OFF Thawing OFF 	<ul style="list-style-type: none"> Check the probe type (P0) Check the probe wiring Change the probe type
Evaporator probe alarm		<ul style="list-style-type: none"> Alarm shown on display Checks on evaporator fan activation are not taken into account Defrost cycle on a time-only basis 	
Condenser probe alarm		<ul style="list-style-type: none"> Alarm shown on display The condenser fan runs in parallel with the compressor Condenser alarm always OFF 	
Product probe alarm		<ul style="list-style-type: none"> If regulation is set to product probe, regulation switches to cold room probe, if configured and they affect the regulators; otherwise: <ul style="list-style-type: none"> The compressor performs ON/OFF cycles Door heater OFF Heaters OFF Thawing OFF 	
Humidity probe alarm		<ul style="list-style-type: none"> Alarm shown on display Dehumidification/humidification OFF 	
High cold room temperature indication	<p>If A5 = 0:</p> <ul style="list-style-type: none"> Temperature Pb1 > A15 for time period = A1 from power-on Temperature Pb1 > A15 for time period = A2 from defrost end Temperature Pb1 > A15 for time period = A3 from door closure Temperature Pb1 > A15 for time period = A6 <p>If A5 = 1:</p> <ul style="list-style-type: none"> Temperature Pb1 > A13 for time period = A1 from power-on Temperature Pb1 > A13 for time period = A2 from defrost end Temperature Pb1 > A13 for time period = A3 from door closure Temperature Pb1 > A13 for time period = A6 	<ul style="list-style-type: none"> Indication shown on display Heaters, humidification and dehumidification OFF 	<ul style="list-style-type: none"> If A5=0, wait for the temperature read by Pb1 < A15 If A5=1, wait for the temperature read by Pb1 < A13

Description	Cause	Effects	Solution
High cold room temperature alarm	<p>If A5 = 0:</p> <ul style="list-style-type: none"> • Temperature Pb1 > A11 for time period = A1 from power-on • Temperature Pb1 > A11 for time period = A2 from defrost end • Temperature Pb1 > A11 for time period = A3 from door closure • Temperature Pb1 > A11 for time period = A6 <p>If A5 = 1:</p> <ul style="list-style-type: none"> • Temperature Pb1 > A9 for time period = A1 from power-on • Temperature Pb1 > A9 for time period = A2 from defrost end • Temperature Pb1 > A9 for time period = A3 from door closure • Temperature Pb1 > A9 for time period = A6 	<ul style="list-style-type: none"> • Alarm shown on display • Heaters, humidification and dehumidification OFF 	<ul style="list-style-type: none"> • If A5=0, wait for the temperature read by Pb1 < A11 • If A5=1, wait for the temperature read by Pb1 < A9
Low cold room temperature indication	<p>If A5 = 0:</p> <ul style="list-style-type: none"> • Temperature Pb1 > A14 for time period = A1 from power-on • Temperature Pb1 > A14 for time period = A2 from defrost end • Temperature Pb1 > A14 for time period = A3 from door closure • Temperature Pb1 > A14 for time period = A6 <p>If A5 = 1:</p> <ul style="list-style-type: none"> • Temperature Pb1 > A12 for time period = A1 from power-on • Temperature Pb1 > A12 for time period = A2 from defrost end • Temperature Pb1 > A12 for time period = A3 from door closure • Temperature Pb1 > A12 for time period = A6 	<ul style="list-style-type: none"> • Indication shown on display • No effect on regulation 	<ul style="list-style-type: none"> • If A5=0, wait for the temperature read by Pb1 < A14 • If A5=1, wait for the temperature read by Pb1 < A12
Low cold room temperature alarm	<p>If A5 = 0:</p> <ul style="list-style-type: none"> • Temperature Pb1 > A10 for time period = A1 from power-on • Temperature Pb1 > A10 for time period = A2 from defrost end • Temperature Pb1 > A10 for time period = A3 from door closure • Temperature Pb1 > A10 for time period = A6 <p>If A5 = 1:</p> <ul style="list-style-type: none"> • Temperature Pb1 > A8 for time period = A1 from power-on • Temperature Pb1 > A8 for time period = A2 from defrost end • Temperature Pb1 > A8 for time period = A3 from door closure • Temperature Pb1 > A8 for time period = A6 	<ul style="list-style-type: none"> • Indication shown on display • Compressor OFF 	<ul style="list-style-type: none"> • If A5=0, wait for the temperature read by Pb1 < A10 • If A5=1, wait for the temperature read by Pb1 < A8

Description	Cause	Effects	Solution
High product temperature indication	<p>If A5b = 0:</p> <ul style="list-style-type: none"> Product temperature > A15b for time period = A1 from power-on Product temperature > A15b for time period = A2 from defrost end Product temperature > A15b for time period = A3 from door closure Product temperature > A15b for time period = A6b <p>If A5b = 1:</p> <ul style="list-style-type: none"> Product temperature > A13b for time period = A1 from power-on Product temperature > A13b for time period = A2 from defrost end Product temperature > A13b for time period = A3 from door closure Product temperature > A13b for time period = A6b 	<ul style="list-style-type: none"> Indication shown on display Heaters, humidification and dehumidification OFF 	<ul style="list-style-type: none"> If A5b=0, wait for the temperature read by the product probe < A15b If A5b=1, wait for the temperature read by the product probe < A13b
High product temperature alarm	<p>If A5b = 0:</p> <ul style="list-style-type: none"> Product temperature > A11b for time period = A1 from power-on Product temperature > A11b for time period = A2 from defrost end Product temperature > A11b for time period = A3 from door closure Product temperature > A11b for time period = A6b <p>If A5b = 1:</p> <ul style="list-style-type: none"> Product temperature > A9b for time period = A1 from power-on Product temperature > A9b for time period = A2 from defrost end Product temperature > A9b for time period = A3 from door closure Product temperature > A9b for time period = A6b 	<ul style="list-style-type: none"> Alarm shown on display Heaters, humidification and dehumidification OFF 	<ul style="list-style-type: none"> If A5b=0, wait for the temperature read by the product probe < A11b If A5b=1, wait for the temperature read by the product probe < A9b
Low product temperature indication	<p>If A5b = 0:</p> <ul style="list-style-type: none"> Product temperature > A14b for time period = A1 from power-on Product temperature > A14b for time period = A2 from defrost end Product temperature > A14b for time period = A3 from door closure Product temperature > A14b for time period = A6b <p>If A5b = 1:</p> <ul style="list-style-type: none"> Product temperature > A12b for time period = A1 from power-on Product temperature > A12b for time period = A2 from defrost end Product temperature > A12b for time period = A3 from door closure Product temperature > A12b for time period = A6b 	<ul style="list-style-type: none"> Alarm shown on display No effect on regulation 	<ul style="list-style-type: none"> If A5b=0, wait for the temperature read by the product probe < A14b If A5b=1, wait for the temperature read by the product probe < A12b

Description	Cause	Effects	Solution
Low product temperature alarm	<p>If A5b = 0:</p> <ul style="list-style-type: none"> Product temperature > A10b for time period = A1 from power-on Product temperature > A10b for time period = A2 from defrost end Product temperature > A10b for time period = A3 from door closure Product temperature > A10b for time period = A6b <p>If A5b = 1:</p> <ul style="list-style-type: none"> Product temperature > A8b for time period = A1 from power-on Product temperature > A8b for time period = A2 from defrost end Product temperature > A8b for time period = A3 from door closure Product temperature > A8b for time period = A6b 	<ul style="list-style-type: none"> Alarm shown on display Compressor OFF 	<ul style="list-style-type: none"> If A5b=0, wait for the temperature read by the product probe < A10b If A5b=1, wait for the temperature read by the product probe < A8b
High evaporator temperature alarm	Temperature Pb2 > A18 for time period = A19	<ul style="list-style-type: none"> Alarm shown on display Heaters, humidification and dehumidification OFF 	Wait for the temperature read by Pb2 < A18
Door open alarm	Digital input activated for a time period > i2	<ul style="list-style-type: none"> Alarm shown on display Regulators inhibited on the basis of i0 	<ul style="list-style-type: none"> If i2 = -1 the alarm is disabled Check i0, i1, i2 and i3 Check the digital input connection Close the door
Condenser overheat indication	Condenser temperature > C6	<ul style="list-style-type: none"> Code COH shown No effect on regulation 	Check C6
Compressor 1 high pressure alarm	Digital input activated: <ul style="list-style-type: none"> i4 = 1 for time period = i6 i7 = 1 for time period = i9 i10 = 1 for time period = i12 	<ul style="list-style-type: none"> Alarm shown on display Compressor OFF Condenser fan ON until switch-off conditions satisfied 	Check for and remove the cause of the alarm on the digital input (automatic reset)
Compressor 1 low pressure alarm	Digital input activated: <ul style="list-style-type: none"> i4 = 3 for time period = i6 i7 = 3 for time period = i9 i10 = 3 for time period = i12 	<ul style="list-style-type: none"> Alarm shown on display Compressor and defrost OFF 	
Compressor 2 high pressure alarm	Digital input activated: <ul style="list-style-type: none"> i4 = 2 for time period = i6 i7 = 2 for time period = i9 i10 = 2 for time period = i12 	<ul style="list-style-type: none"> Alarm shown on display Compressor OFF Condenser fan ON until switch-off conditions satisfied 	
Compressor 2 low pressure alarm	Digital input activated: <ul style="list-style-type: none"> i4 = 4 for time period = i6 i7 = 4 for time period = i9 i10 = 4 for time period = i12 	<ul style="list-style-type: none"> Alarm shown on display Compressor and defrost OFF 	
Compressor 1 thermal switch alarm	Digital input activated: <ul style="list-style-type: none"> i4 = 5 for time period = i6 i7 = 5 for time period = i9 i10 = 5 for time period = i12 	<ul style="list-style-type: none"> Alarm shown on display Compressor OFF 	
Compressor 2 thermal switch alarm	Digital input activated: <ul style="list-style-type: none"> i4 = 6 for time period = i6 i7 = 6 for time period = i9 i10 = 6 for time period = i12 	<ul style="list-style-type: none"> Alarm shown on display Compressor OFF 	Check for and remove the cause of the alarm on the digital input (automatic reset)
Fan thermal switch alarm	Digital input activated: <ul style="list-style-type: none"> i4 = 11 for time period = i6 i7 = 11 for time period = i9 i10 = 11 for time period = i12 	<ul style="list-style-type: none"> Alarm shown on display Evaporator fan OFF 	
System protection alarm	Digital input activated: <ul style="list-style-type: none"> i4 = 7 for time period = i6 i7 = 7 for time period = i9 i10 = 7 for time period = i12 	<ul style="list-style-type: none"> Alarm shown on display All regulators are switched off 	

Description	Cause	Effects	Solution
Power failure alarm	Power failure for time period > P3	<ul style="list-style-type: none"> Alarm shown on display No effect on regulation 	<ul style="list-style-type: none"> If P3 = -1 the alarm is disabled Check the power supply wiring
High condensation temperature indication	With Pr1...Pr3 = 2: Condenser temperature > C6	<ul style="list-style-type: none"> Alarm shown on display Compressor OFF Evaporator fan OFF Condenser fan ON 	Check C6
High condensation temperature alarm	With Pr1...Pr3 = 2: Condenser temperature > C7 for time period = C8	<ul style="list-style-type: none"> Alarm shown on display Compressor OFF Evaporator fan OFF Condenser fan ON Thawing OFF 	<ul style="list-style-type: none"> Switch the instrument off and on again; Check C7 and C8
Generic alarm iA	Digital input activated: <ul style="list-style-type: none"> i1 = 9 for time period = i6 i7 = 9 for time period = i9 i10 = 9 for time period = i12 	<ul style="list-style-type: none"> Generic alarm iA shown No effect on regulation 	Check for and remove the cause of the alarm on the digital input (automatic reset)
Compressor maintenance alarm	Compressor hours > C10	<ul style="list-style-type: none"> Alarm shown on display The compressor performs ON/OFF cycles on the basis of C11 and C12 	<ul style="list-style-type: none"> Carry out compressor maintenance Reset maintenance counter hours
Defrost timeout alarm	With d11 =1, defrost ends due to timeout d3 instead of temperature d2 being reached	<ul style="list-style-type: none"> Alarm shown on display No effect on regulation 	<ul style="list-style-type: none"> Tap any key Check d2, d3 and d11
RTC alarm	RTC not working alarm	<ul style="list-style-type: none"> Functions connected to the RTC not present or not synchronised with the actual time The data-logger saves the information with an incorrect date and time 	Set the correct time. If the error persists, replace the instrument (RTC battery exhausted)
Base communication alarm	No communication between base board and user interface	<ul style="list-style-type: none"> Alarm shown on display All regulators are switched off 	<ul style="list-style-type: none"> Restore communication between base board and user interface Automatic reset
Expansion device communication alarm	If present, E19 = 1, 3: No communication between base board and expansion device	<ul style="list-style-type: none"> Alarm shown on display All expansion device outputs deactivated 	<ul style="list-style-type: none"> Restore communication with the expansion device Automatic reset
Backup module communication alarm	If present, E19 = 2, 3: No communication between base board and backup module	<ul style="list-style-type: none"> Alarm shown on display The alarms corresponding to the backup module are deactivated 	<ul style="list-style-type: none"> Restore communication with the backup module Automatic reset
Battery fault alarm	Battery low or the controller is not detecting the battery	<ul style="list-style-type: none"> Alarm shown on display No effect on regulation 	Replace the battery
Emergency power supply alarm	The controller is not powered by the mains (the backup battery has cut in)	<ul style="list-style-type: none"> The display comes on for 5 s and is switched off for 10s 	Restore the mains power supply connection
CO ₂ backup alarm	If E19 = 2, 3 or u14c = 2: Backup module probe temperature (Pr4 ≠0) > u9+u10 for time period = u8	<ul style="list-style-type: none"> Alarm shown on display No effect on regulation 	Wait for the temperature read by the module probe < u9+u10
Anti-thawing alarm	If E19 = 2, 3 or u14c = 4: Backup module probe temperature (Pr4 ≠0) < u9	<ul style="list-style-type: none"> Alarm shown on display No effect on regulation 	Wait for the temperature read by the module probe > u9
Thermostat alarm	If E19 = 2, 3 or u14c = 4: Backup module probe temperature (Pr4 ≠0) > u9+u10	<ul style="list-style-type: none"> Alarm shown on display No effect on regulation 	Wait for the temperature read by the module probe < u9+u10
Water filling alarm	Water filling time > u12	<ul style="list-style-type: none"> Alarm shown on display Water filling output deactivated 	<ul style="list-style-type: none"> Check the connection to the water filling system Automatic reset

9.2 MISTRAL HUMIDIFIER ALARM TABLE

Description	Cause	Effects	Solution
Inlet solenoid valve minimum current indication	Absorption thresholds exceeded in normal operation	<ul style="list-style-type: none"> Inlet solenoid valve OFF If CFG = 0...4 then Out1 (Mistral) is activated LED blinks 0.5 s ON / 5 s OFF 	<ul style="list-style-type: none"> Schedule maintenance and/or component replacement
Inlet solenoid valve maximum current indication	Absorption thresholds exceeded in normal operation	<ul style="list-style-type: none"> No effect on regulation If CFG = 0...4 then Out1 (Mistral) is activated LED blinks 0.5 s ON / 5 s OFF 	<ul style="list-style-type: none"> Contact ELSTEAM technical support
Outlet solenoid valve minimum current indication	Absorption thresholds exceeded in normal operation	<ul style="list-style-type: none"> Outlet solenoid valve OFF If CFG = 0...4 then Out1 (Mistral) is activated LED blinks 0.5 s ON / 5 s OFF 	<ul style="list-style-type: none"> Schedule maintenance and/or component replacement
Outlet solenoid valve maximum current indication	Absorption thresholds exceeded in normal operation	<ul style="list-style-type: none"> No effect on regulation If CFG = 0...4 then Out1 (Mistral) is activated LED blinks 0.5 s ON / 5 s OFF 	<ul style="list-style-type: none"> Contact ELSTEAM technical support
Mist-maker minimum current indication	Absorption thresholds exceeded in normal operation	<ul style="list-style-type: none"> No effect on regulation If CFG = 0...4 then Out1 (Mistral) is activated LED blinks 0.5 s ON / 5 s OFF 	<ul style="list-style-type: none"> Schedule maintenance and/or component replacement
Mist-maker maximum current indication	Absorption thresholds exceeded in normal operation	<ul style="list-style-type: none"> Mist-maker OFF If CFG = 0...4 then Out1 (Mistral) is activated LED blinks 0.5 s ON / 5 s OFF 	<ul style="list-style-type: none"> Contact ELSTEAM technical support
Fan minimum current indication	Absorption thresholds exceeded in normal operation	<ul style="list-style-type: none"> No effect on regulation If CFG = 0...4 then Out1 (Mistral) is activated LED blinks 0.5 s ON / 5 s OFF 	<ul style="list-style-type: none"> Schedule maintenance and/or component replacement
Fan maximum current indication	Absorption thresholds exceeded in normal operation	<ul style="list-style-type: none"> Fan OFF If CFG = 0...4 then Out1 (Mistral) is activated LED blinks 0.5 s ON / 5 s OFF 	<ul style="list-style-type: none"> Contact ELSTEAM technical support
Inlet solenoid valve minimum current alert	Absorption thresholds exceeded in normal operation	<ul style="list-style-type: none"> Inlet solenoid valve OFF If CFG = 0...4 then Out1 (Mistral) is activated LED blinks 0.5 s ON / 5 s OFF 	<ul style="list-style-type: none"> Replace the inlet solenoid valve
Inlet solenoid valve maximum current alert	Absorption thresholds exceeded in normal operation	<ul style="list-style-type: none"> No effect on regulation If CFG = 0...4 then Out1 (Mistral) is activated LED blinks 0.5 s ON / 5 s OFF 	<ul style="list-style-type: none"> Contact ELSTEAM technical support
Outlet solenoid valve minimum current alert	Absorption thresholds exceeded in normal operation	<ul style="list-style-type: none"> Outlet solenoid valve OFF If CFG = 0...4 then Out1 (Mistral) is activated LED blinks 0.5 s ON / 5 s OFF 	<ul style="list-style-type: none"> Replace the outlet solenoid valve
Outlet solenoid valve maximum current alert	Absorption thresholds exceeded in normal operation	<ul style="list-style-type: none"> No effect on regulation If CFG = 0...4 then Out1 (Mistral) is activated LED blinks 0.5 s ON / 5 s OFF 	<ul style="list-style-type: none"> Contact ELSTEAM technical support
Mist-maker minimum current alert	Absorption thresholds exceeded in normal operation	<ul style="list-style-type: none"> No effect on regulation If CFG = 0...4 then Out1 (Mistral) is activated LED blinks 0.5 s ON / 5 s OFF 	<ul style="list-style-type: none"> Replace the mist-maker
Mist-maker maximum current alert	Absorption thresholds exceeded in normal operation	<ul style="list-style-type: none"> Mist-maker OFF If CFG = 0...4 then Out1 (Mistral) is activated LED blinks 0.5 s ON / 5 s OFF 	<ul style="list-style-type: none"> Contact ELSTEAM technical support
Fan minimum current alert	Absorption thresholds exceeded in normal operation	<ul style="list-style-type: none"> No effect on regulation If CFG = 0...4 then Out1 (Mistral) is activated LED blinks 0.5 s ON / 5 s OFF 	<ul style="list-style-type: none"> Automatic reactivation
Fan maximum current alert	Absorption thresholds exceeded in normal operation	<ul style="list-style-type: none"> Fan OFF If CFG = 0...4 then Out1 (Mistral) is activated LED blinks 0.5 s ON / 5 s OFF 	<ul style="list-style-type: none"> Contact ELSTEAM technical support
Mist-maker operating hours alert	<ul style="list-style-type: none"> If P1 = 70...449 $\mu\text{S}\cdot\text{cm}$, operating hours > A10 If P1 = 450...849 $\mu\text{S}\cdot\text{cm}$, operating hours > A11 If P1 = 850...1250 $\mu\text{S}\cdot\text{cm}$, operating hours > A12 	<ul style="list-style-type: none"> No effect on regulation If CFG = 0...4 then Out1 (Mistral) is activated LED blinks 0.5 s ON / 5 s OFF 	Carry out maintenance
Fan operating hours alert	Fan operating hours > A13	<ul style="list-style-type: none"> No effect on regulation If CFG = 0...4 then Out1 (Mistral) is activated LED blinks 0.5 s ON / 5 s OFF 	Carry out maintenance
Low humidity alarm	RH sensor < A5 for a time A7	<ul style="list-style-type: none"> No effect on regulation LED blinks 1 s ON / 1 s OFF 	Reactivation is automatic if RH sensor > A5 + 2 %
High humidity alarm	RH sensor > A6 for a time A7	<ul style="list-style-type: none"> No effect on regulation LED blinks 0.5 s ON / 0.5 s OFF 	Reactivation is automatic if RH sensor < A6 - 2 %

Description	Cause	Effects	Solution
Level board high temperature alert	Impurities in the water in the reservoir	<ul style="list-style-type: none"> No effect on regulation If CFG = 0...4 then Out1 (Mistral) is activated LED blinks 0.5 s ON / 5 s OFF 	<ul style="list-style-type: none"> Check the characteristics of the water Clean the reservoir Switch the humidifier off and on again

NOTE: Refer to the operating and maintenance manual for the Mistral humidifier at the website www.elsteam.it

9.3 INVERTER ALARM TABLE

Description	Effects	Solution
Communication timeout alarm	Modbus communication interrupted	Check and restore the modbus connection
Inverter synchronisation alarm	No communication between Vcolor and inverter	Check and restore the connection between the Vcolor and inverter
Undervoltage alarm	The voltage value of the device has dropped below the minimum value set via parameter S602	Reset alarm via suggested input
Overvoltage alarm	The voltage value of the device has exceeded the maximum value set via parameter S603	
Overcurrent alarm	The device has exceeded the maximum current value set via parameter S601	
Overload alarm	When the amount of energy according to logic I x t exceeds the value set via parameters S511 and S512	
Cooler overtemperature alarm	The motor has reached and exceeded maximum temperature S606	The alarm resets automatically when the temperature of the device < S606 - 10 °C (50 °F)

This document and the solutions contained within it are the intellectual property of EVCO, safeguarded by the Italian Industrial Property Code (CPI). EVCO forbids the reproduction and distribution, even in part, of the contents, unless express authorisation is obtained directly from EVCO.

Each user or integration specialist should conduct their own complete and appropriate risk analysis, in addition to carrying out a product evaluation and test in relation to its specific application or use.

Neither EVCO nor any of its associates or subsidiaries shall be held responsible or liable for improper use of the information contained herein.

MADE IN ITALY

EVCO S.p.A.

Via Feltre 81, 32036 Sedico (BL) ITALY

Telephone: +39 0437 8422

Fax: +39 0437 83648

email: info@evco.it

Web: www.evco.it