

PANASONIC SCROLL COMPRESSORS

Code : 809 930 88

Model : C-SBN263H8A

Aproved for R407C, R448A, R449A, R134a, R513A, R404A



Panasonic Appliances Compressor (Dalian) Co.,Ltd.

Section 1. General Specifications

Model C-SBN263H8A
Refrigerant R407C

Electrical 380-415 Volts 3 Phase 50Hz
440-460 Volts 3 Phase 60Hz

Nominal Performance at ARI

	50Hz-380V	60Hz-440V
Power Source	<u>50Hz-380V</u>	<u>60Hz-440V</u>
Capacity (W)	<u>9600</u>	<u>11800</u>
Power (W)	<u>3350</u>	<u>4100</u>
Current (A)	<u>6.2</u>	<u>6.4</u>
COP (W/W)	<u>2.87</u>	<u>2.88</u>
Mass Flow (kg/h)	<u>230</u>	<u>284</u>

Rating Conditions (MID Point)

Condensing Temperature(°C)	<u>54.4</u>
Evaporating Temperature(°C)	<u>7.2</u>
Return Gas temperature(°C)	<u>18.3</u>
Liquid Temperature(°C)	<u>43.8</u>
Ambient Temperature(°C)	<u>35</u>

Motor

	50Hz	60Hz
Voltage Range(V)	<u>342-456</u>	<u>396-506</u>
RLA (A)	<u>7.3</u>	
MCC (A)	<u>10.2</u>	
LRA (A)	<u>48</u>	<u>51</u>
RPM (min ⁻¹)	<u>2900</u>	<u>3450</u>

Compressor

Maximum Discharge Temp(°C)	<u>130</u>
Displacement (cm ³ /rev)	<u>55.7</u>
Weight (with oil kg)	<u>36.5</u>

Oil

Oil Type	<u>FV68S</u>
Initial Charge (ml)	<u>1700</u>
Re-charge (ml)	<u>1600</u>

Electrical Components

Motor Protector Type	<u>Internal</u>
Run Capacitor Rating (MFD/Volts)	<u>n/a</u>

Winding Resistance at 25°C

	<u>3.177</u>
U-V	<u>3.177</u>
U-W	<u>3.177</u>
V-W	<u>2.966</u>

Sound level	50Hz/380V	60Hz/440V
(db)	<u>62Max</u>	<u>65Max</u>

Nominal performance values +/-5% with 1 hr run-in.

Ratings with air over compressor.

Sound level is an average sound pressure level in four directions. MIC location is the distance of 1m from the compressor Specifications subject to change without notice.

Minimum Starting Voltage

Power Source (3PH)	Hz	50	60
Minimum Starting Voltage	V	304	352

Conditions

Compressor Temp.	°C (°F)	10~60(50~140)
Ambient Temp.	°C (°F)	10~40(50~105)
High Pressure	MPa(G)/psig	2(290)
Low Pressure	MPa(G)/psig	0.5(72)

Inernal Motor Protector (in compressor)

Parts Name	Specification	
Inernal Motor Protector	TripTemp.	155±5°C
	Reset Temp.	61±9°C
	Trip Current	43A / 2~10s

Others

Content	Unit	Specification	
Design Pressure	L.P. S.	MPa(G)/psig	1.6(232)
	H. P. S.	MPa(G)/psig	3.3(479)
Insulation Resistance	MΩ	100 (without refrigerant)	
Dielectric Strength	v	2400 (1 second)	
Residual Moisture	mg	300	

Note:
1. The insulation resistance be measured with a DC500V megohm test

Accessories List

Parts Name	Qty	Parts code	Revision No.	Note
Terminal Box Cover	1	A-0101-DSB	0	Installed on Compressor
Terminal Box Clip	1	A-0201-DSB	0	Installed on Compressor
Insulating Grommet	1	A-0301-DSB	0	Installed on Compressor
Mounting Grommet	4	M-0101-DSB	0	Included with Compressor
Mounting Sleeve	4	M-0201-DSB	0	Included with Compressor
Screw Special	1	B-0101-DSB	0	Installed on Compressor

Section 2. Compressor Protection

2.1 Protection Required but not Included with compressor

Protection Device	Items	Specifications
Reversal Defensible Relay	Features	To protect the compressor from reverse rotation
	Rated Voltage	AC380V
Crankcase Heater	Rated Power	35 Watts
Discharge Thermostat	Mounting Position	Located within 100mm(4 in)from the compressor shell
	Trip Temperature	130±5°C(266 ±10 °F)
	Reset Temperature	95±11°C (205 ± 20 °F)
High Pressure Switch	Setting	Cut-out seting no higher than 3.2MPa(G)
Low Pressure Switch	Setting	Cut-out seting no lower than 0.05MPa(G)

2.2 Position of the Protection and Refrigerant Charging

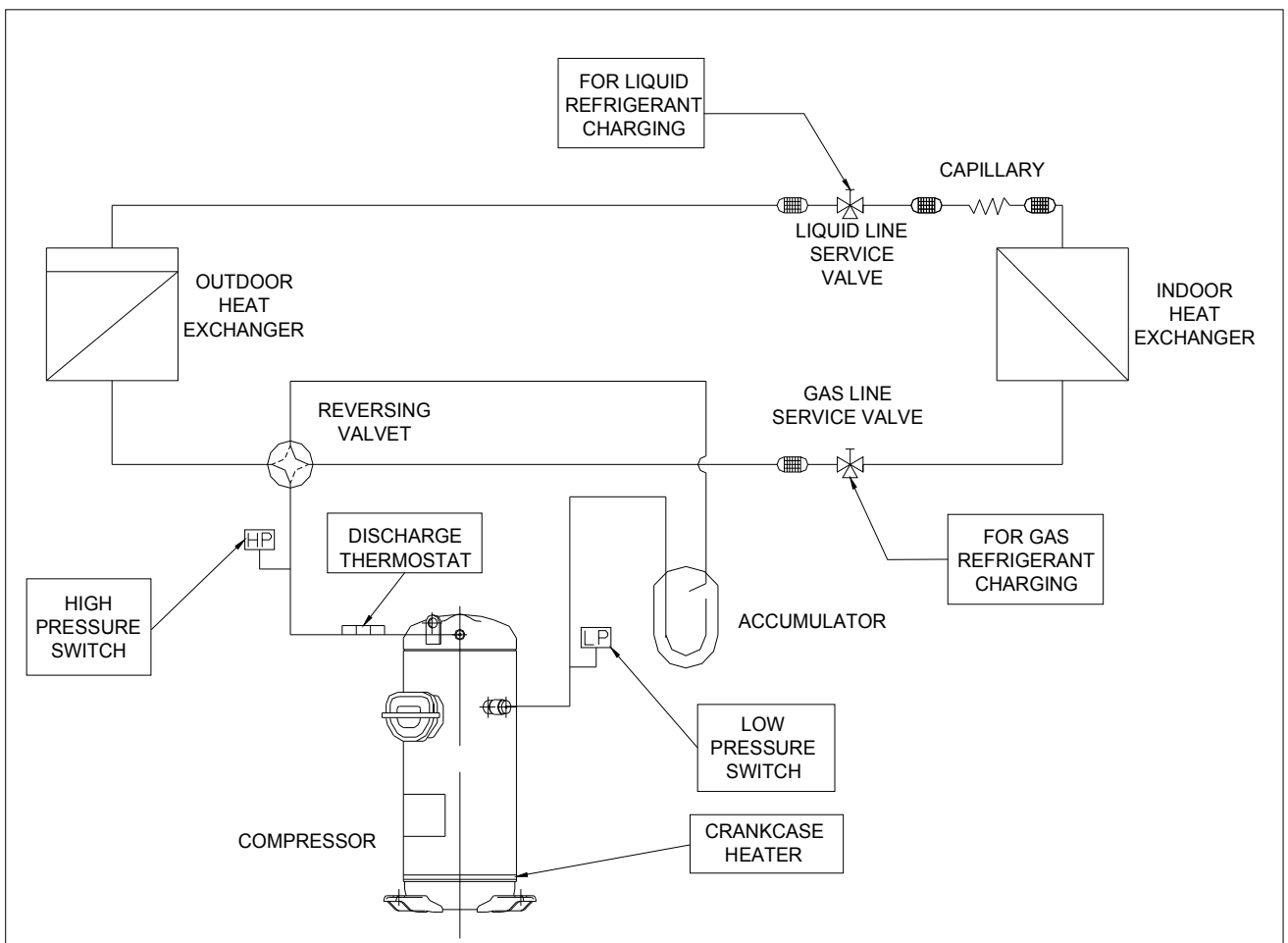

Section 3. Performance data

PERFORMANCE DATA

Compressor Model(Code)	C-SBN263H8A (809 930 88)
Power Source	3PH 50Hz 380-415V
Suction Gas Superheat(K)	9
Sub Cooling(K)	8.3
Compressor Cooling	Natural Cooling
Refrigerant	R407C

CAPACITY(W)

Condensing Temperature(°C)	Evaporating Temperature(°C)							
	-15	-10	-6.7	0	4.4	7.2	10	12
35.0	5,260	6,420	7,330	9,590	11,440	12,800	14,320	15,520
40.5	4,790	5,870	6,710	8,810	10,540	11,810	13,230	14,360
45.0	4,430	5,440	6,240	8,220	9,850	11,050	12,400	13,460
50.0	4,060	5,010	5,740	7,600	9,120	10,250	11,520	12,520
54.4		4,650	5,340	7,090	8,530	9,600	10,800	11,750
60.0			4,880	6,490	7,830	8,830	9,950	10,840
65.0				6,010	7,270	8,200	9,260	10,100

POWER(W)

Condensing Temperature(°C)	Evaporating Temperature(°C)							
	-15	-10	-6.7	0	4.4	7.2	10	12
35.0	2,160	2,170	2,170	2,160	2,150	2,140	2,120	2,110
40.5	2,440	2,440	2,440	2,440	2,430	2,410	2,400	2,390
45.0	2,700	2,710	2,710	2,700	2,690	2,680	2,670	2,660
50.0	3,030	3,040	3,040	3,040	3,030	3,020	3,010	3,000
54.4		3,360	3,370	3,370	3,360	3,350	3,340	3,330
60.0			3,830	3,840	3,830	3,820	3,810	3,800
65.0				4,300	4,290	4,290	4,280	4,270

CURRENT(A)

@380V

Condensing Temperature(°C)	Evaporating Temperature(°C)							
	-15	-10	-6.7	0	4.4	7.2	10	12
35.0	4.2	4.2	4.3	4.3	4.3	4.3	4.3	4.3
40.5	4.7	4.7	4.8	4.8	4.8	4.8	4.7	4.7
45.0	5.2	5.2	5.2	5.2	5.2	5.2	5.2	5.2
50.0	5.8	5.8	5.8	5.7	5.7	5.7	5.7	5.7
54.4		6.4	6.3	6.3	6.2	6.2	6.2	6.2
60.0			7.1	7.0	6.9	6.9	6.9	6.9
65.0				7.7	7.6	7.6	7.6	7.6

NOTE:

- * The performance values are based on MID point method.
- * The performance values subject to change without notice.

Compressor Model(Code)
Power Source

C-SBN263H8A (809 930 88)
3PH 50Hz 380-415V

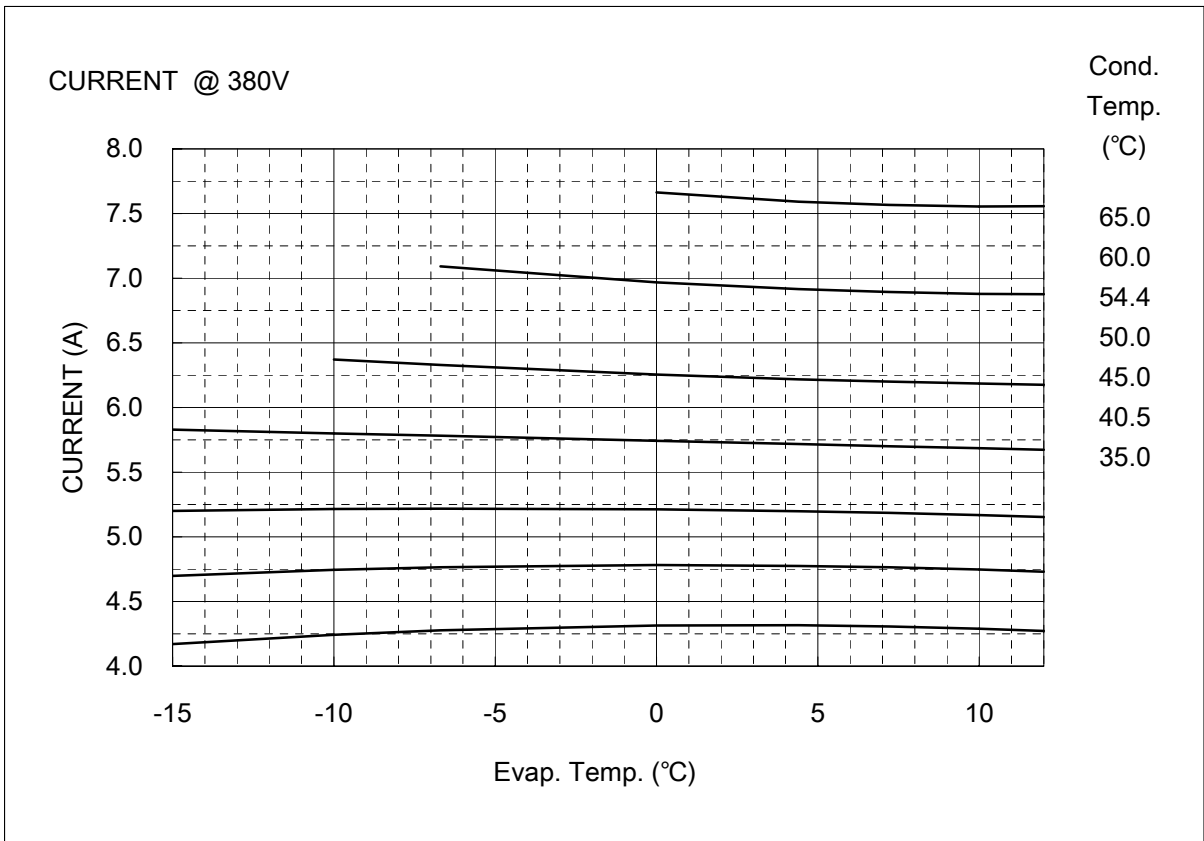
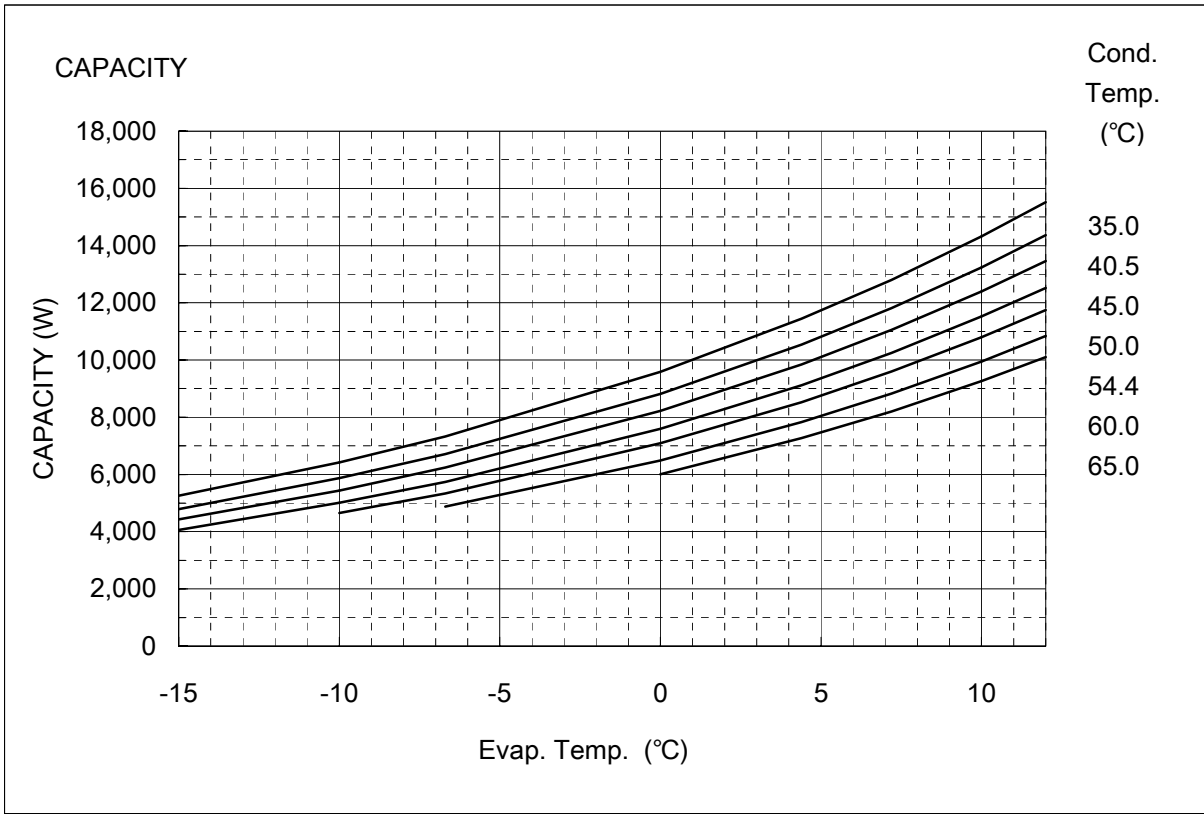

COEFFICIENTS OF PERFORMANCE CURVES

Compressor Model **C-SBN263H8A (809 930 88)**
 Power Source **3PH 50Hz 380-415V**
 Suction Gas Superheat (K) **9**
 Sub Cooling (K) **8.3**
 Compressor Cooling **Natural Cooling**
 Refrigerant **R407C**

$$X=C1+C2*(S)+C3*D+C4*(S^2)+C5*(S*D)+C6*(D^2)+C7*(S^3)+C8*(D*S^2)+C9*(S*D^2) +C10*(D^3)$$

X—CAPACITY(W) OR POWER(W) OR CURRENT(A) OR FLOW(kg/h)

S—EVAPORATING TEMP, °C

D—CONDENSING TEMP, °C

380V-50Hz	CAPACITY (W)	POWER (W)	CURRENT (A)
C1	1.584856E+04	1.591341E+03	3.013003E+00
C2	5.966492E+02	-1.417228E+00	7.185024E-04
C3	-2.110736E+02	-1.335040E+01	-2.619542E-03
C4	1.051167E+01	-1.355647E-01	-1.999940E-03
C5	-6.994694E+00	-6.796510E-02	4.221289E-04
C6	9.185084E-01	8.458923E-01	1.142654E-03
C7	9.328952E-02	-1.479324E-03	3.080586E-06
C8	-7.498673E-02	-4.564635E-04	4.116685E-05
C9	2.775751E-02	1.362023E-03	-1.112836E-05
C10	6.936612E-09	-1.539886E-09	-1.357605E-11

Note:The polynomial coefficients subject to change without notice.

PERFORMANCE DATA

Compressor Model(Code)	C-SBN263H8A (809 930 88)
Power Source	3PH 60Hz 440-460V
Suction Gas Superheat(K)	9
Sub Cooling(K)	8.3
Compressor Cooling	Natural Cooling
Refrigerant	R407C

CAPACITY(W)

Condensing Temperature(°C)	Evaporating Temperature(°C)							
	-15	-10	-6.7	0	4.4	7.2	10	12
35.0	6,480	7,880	8,970	11,650	13,840	15,440	17,230	18,630
40.5	5,920	7,230	8,240	10,760	12,810	14,320	16,010	17,330
45.0	5,500	6,730	7,680	10,070	12,020	13,460	15,060	16,330
50.0	5,060	6,210	7,110	9,350	11,190	12,550	14,070	15,270
54.4		5,790	6,640	8,760	10,510	11,800	13,250	14,400
60.0			6,080	8,060	9,700	10,910	12,280	13,360
65.0				7,490	9,040	10,190	11,480	12,500

POWER(W)

Condensing Temperature(°C)	Evaporating Temperature(°C)							
	-15	-10	-6.7	0	4.4	7.2	10	12
35.0	2,720	2,720	2,720	2,710	2,700	2,690	2,690	2,680
40.5	3,020	3,030	3,030	3,030	3,030	3,020	3,010	3,010
45.0	3,290	3,320	3,330	3,340	3,340	3,330	3,320	3,320
50.0	3,630	3,670	3,700	3,720	3,720	3,720	3,710	3,700
54.4		4,020	4,050	4,090	4,100	4,100	4,090	4,080
60.0			4,560	4,620	4,640	4,630	4,630	4,610
65.0				5,140	5,160	5,160	5,150	5,140

CURRENT(A)

@440V

Condensing Temperature(°C)	Evaporating Temperature(°C)							
	-15	-10	-6.7	0	4.4	7.2	10	12
35.0	4.5	4.5	4.5	4.5	4.5	4.5	4.5	4.5
40.5	4.9	4.9	5.0	5.0	5.0	4.9	4.9	4.9
45.0	5.3	5.3	5.4	5.4	5.4	5.4	5.4	5.4
50.0	5.7	5.8	5.8	5.9	5.9	5.9	5.9	5.9
54.4		6.3	6.3	6.4	6.4	6.4	6.4	6.4
60.0			7.0	7.1	7.1	7.1	7.1	7.1
65.0				7.7	7.8	7.8	7.8	7.8

NOTE:

- * The performance values are based on MID point method.
- * The performance values subject to change without notice.

Compressor Model(Code)
Power Source

C-SBN263H8A (809 930 88)
3PH 60Hz 440-460V

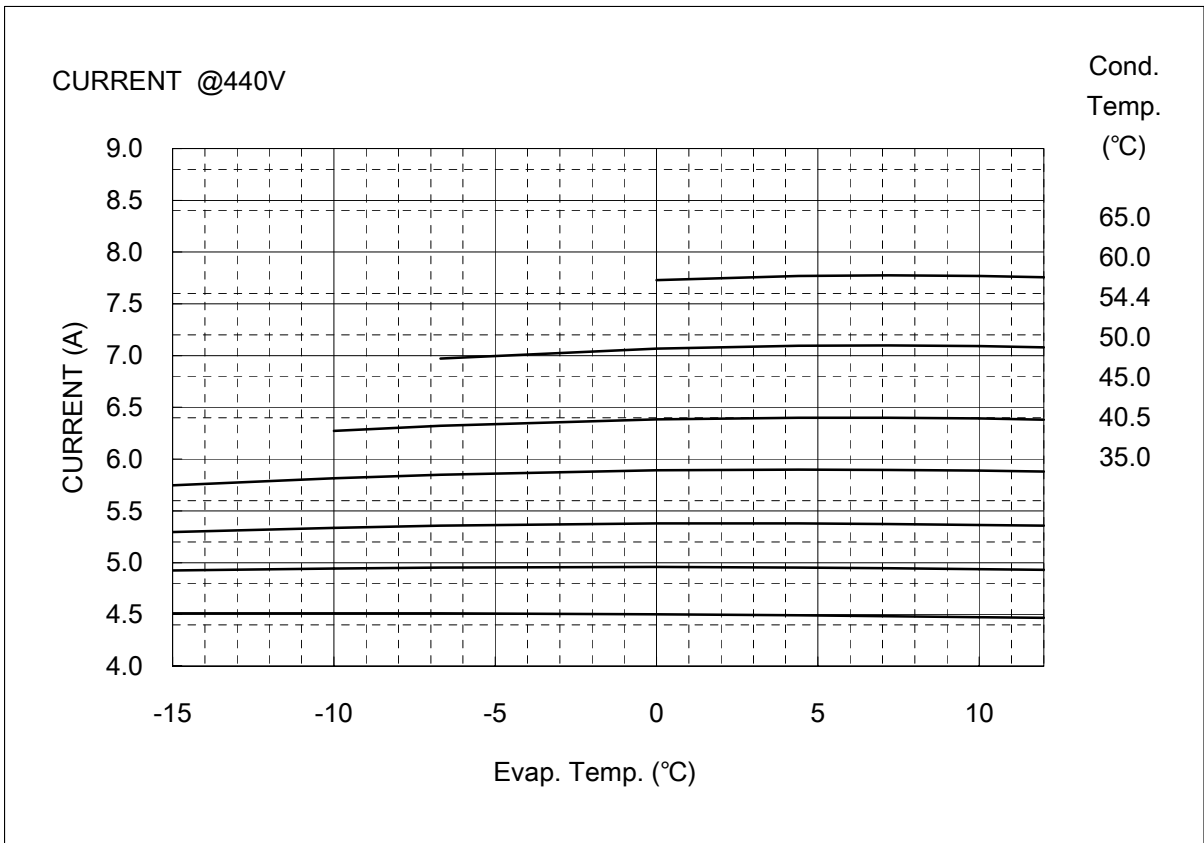
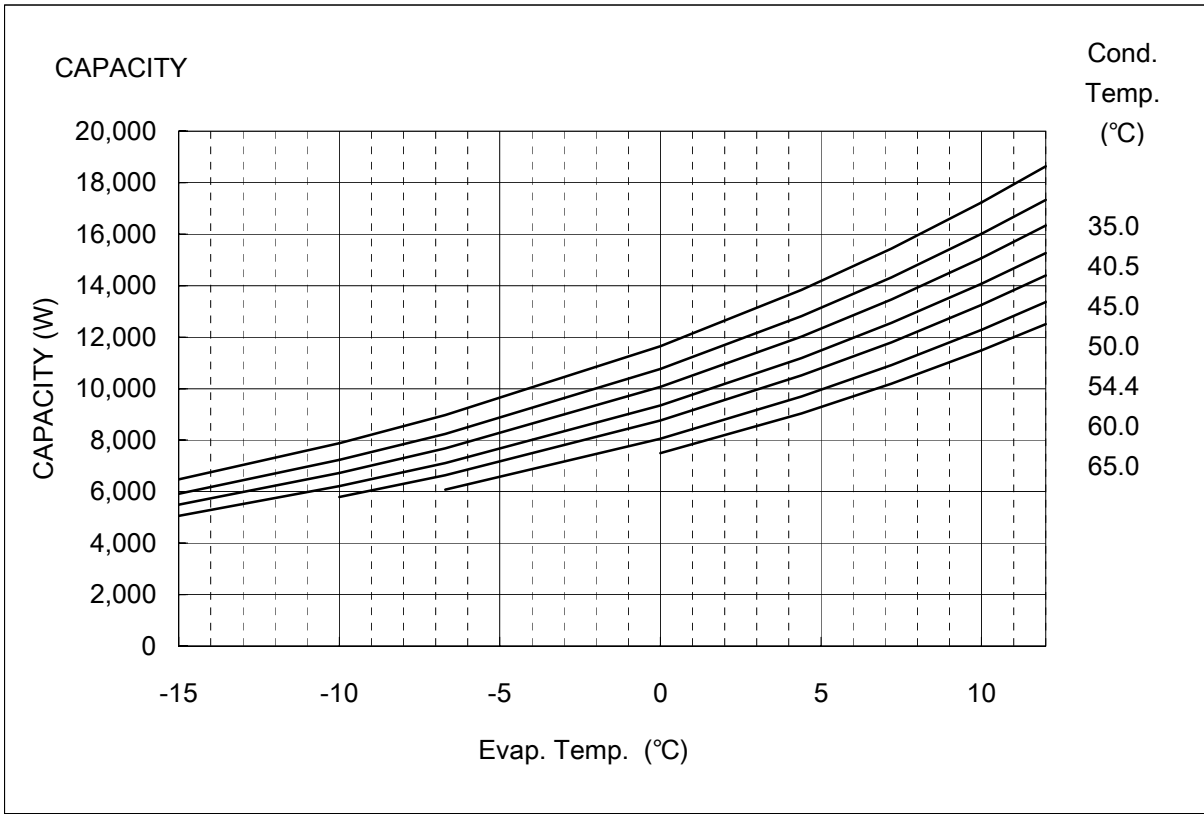

COEFFICIENTS OF PERFORMANCE CURVES

Compressor Model **C-SBN263H8A (809 930 88)**
 Power Source **3PH 60Hz 440-460V**
 Suction Gas Superheat (K) **9**
 Sub Cooling (K) **8.3**
 Compressor Cooling **Natural Cooling**
 Refrigerant **R407C**

$$X=C1+C2*(S)+C3*D+C4*(S^2)+C5*(S*D)+C6*(D^2)+C7*(S^3)+C8*(D*S^2)+C9*(S*D^2) +C10*(D^3)$$

X—CAPACITY(W) OR POWER(W) OR CURRENT(A) OR FLOW(kg/h)

S—EVAPORATING TEMP, °C

D—CONDENSING TEMP, °C

440V-60Hz	CAPACITY (W)	POWER (W)	CURRENT (A)
C1	1.876717E+04	1.883485E+03	2.948552E+00
C2	6.753423E+02	-2.987259E-01	-2.086318E-03
C3	-2.383428E+02	-7.392815E+00	1.015761E-02
C4	1.163682E+01	6.334747E-01	7.854054E-04
C5	-7.131043E+00	-2.249525E-01	-2.326093E-04
C6	9.978926E-01	8.832812E-01	9.744790E-04
C7	1.073469E-01	-4.390099E-04	-1.167962E-06
C8	-7.256734E-02	-1.872041E-02	-2.394198E-05
C9	2.535770E-02	5.348912E-03	6.983738E-06
C10	-1.390836E-09	1.025294E-08	7.528350E-12

Note:The polynomial coefficients subject to change without notice.

Section 4. Operating Envelope

Suction Gas
Superheat :9K
Refrigerant : R407C

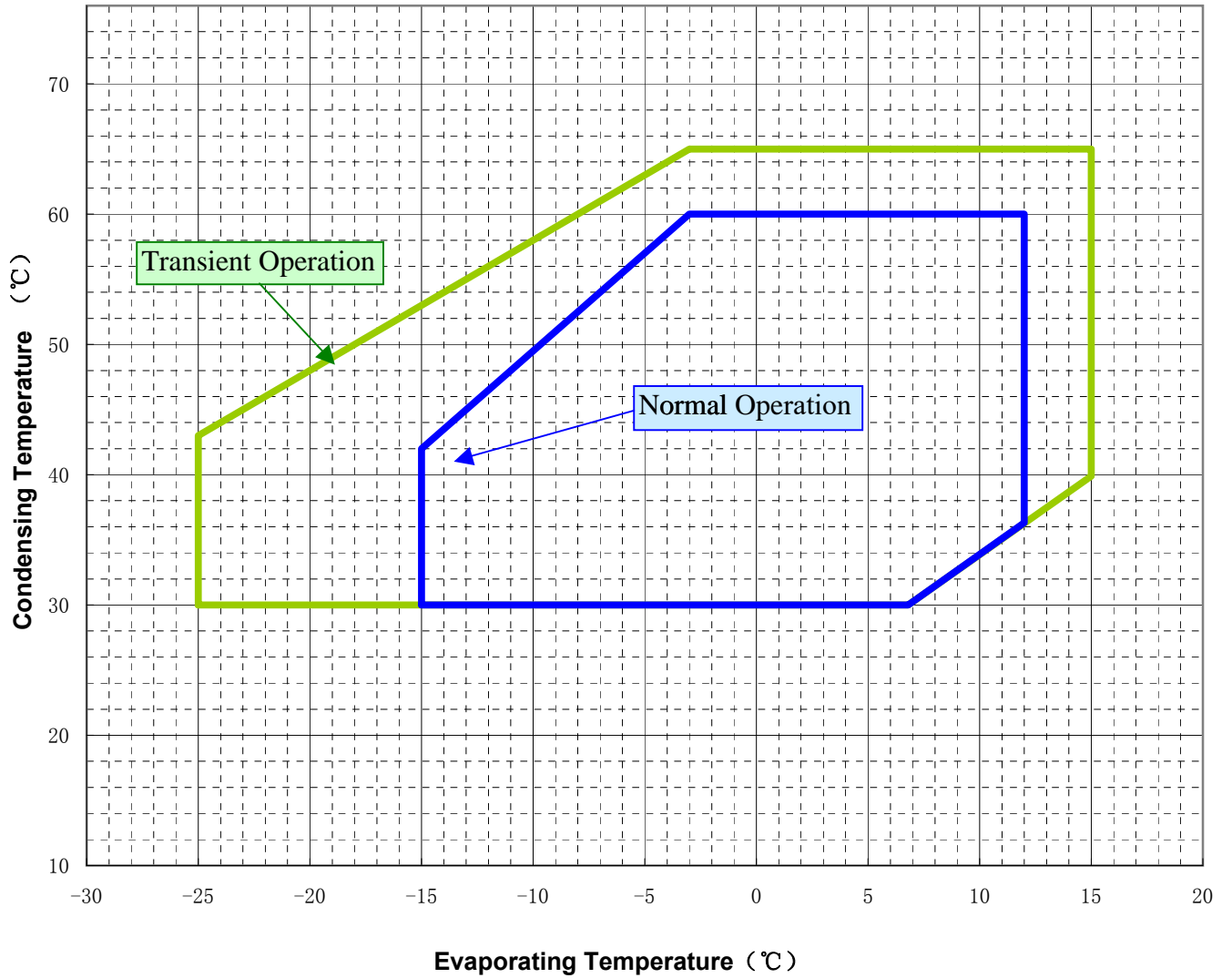

Section 5. Application Standard & Limit

The following requirements apply to vertical type hermetic scroll compressors:

Standard: Applicable to ordinary conditions in Japan JIS B8616 or standards relative to JIS B8616, such as standard rating conditions, maximum operating conditions, low temperature conditions, etc.

Limit: Applicable to transitional brief period of time, such as start-up and beginning of defrost mode.

No.	Item	Standard	Limit	Remark
1	Refrigerant	R407C(Refrigerant must meet a criterion)		
2	Average Evap. Temp.	-15~12°C(5~54 ° F) 0.20~0.65MPa(G)(29~94psig)	-25~15°C(-13~59 ° F) 0.07~0.73MPa(G)(10~106psig)	Average temp. of evaporator Inlet and outlet.
3	Average Cond.Temp.	30~60°C(86~140 ° F) 1.17~2.56MPa(G)(170~371psig)	65°C(149 ° F) 2.88MPa(G)(418psig)	Average temp. of condensor Inlet and outlet.
4	Compression Ratio	2 ~ 6	10	
5	Winding Temp.	115°C(240 °F) Max.	125°C(257 °F)	
6	Shell Bottom Temp.	90°C(194 °F) Max.		
		Evaporating Temp.+12°C(21 °F) Min.		Operating
		Ambient Temp.+11°C(20 °F) Min.		Not Operating
7	Discharge Gas Temp.	115°C(240 °F) Max.	C-SB:130°C(266°F) Max.	Temp. within 10cm of the discharge fitting.
			C-SC:135°C(275°F) Max.	Temp. inside of the copper pipe on the top of compressor
8	Suction Gas Temp.	Superheat: 5K(10 °F)Min.	No excessive noise.	It should meet the requirement of item 5, 6, 7 and 14 within 30cm of the suction fitting.
9	Running Voltage	Within ±10% of the rated voltage		Voltage at compressor terminals.
10	Starting Voltage	Three Phase Models: 85% of the rated voltage min.		Voltage at compressor terminals.
		Single Phase Models: 90% of the rated voltage min.		
11	On/Off Cycling	On Period: Until the oil level returns to the center of the lower bearing Off Period: Until balance of high and low pressure is obtained		For at least 7 minutes - on/3 minutes-off is recommended.
12	Refrigerant Charge	Oil/Refrigerant(wt.)>0.35.		Specific gravity of the Oil:0.94.
13	Life Time	200,000 cycle		
14	Minimum Oil Level	C-SB:Center of the lower bearing	C-SB:Bottom of the lower bearing	
		C-SC:No less than 70% of the initial oil charge		
15	Abnormal Pressure Rise/Drop	Pressure Rise: 3.20MPa(G) (464psig) Max.		By high pressure switch
		Pressure Drop: 0.05MPa(G) (7.3psig) Min.		By low pressure switch
16	System Moisture Level	200ppm Max.		
17	System Uncondensable Gas Level	1 Vol.% Max. Residual Oxygen 0.1 Vol.% Max.		24 hrs. after vacuuming: 1.01kPa Max.
18	Tilt	5Deg.Max.		

(G): Gauge Pressure

Notes

- 1 Installation should be completed within 15 minutes after removing the rubber plugs.
- 2 Do not use the compressor to compress air.
- 3 Do not energize the compressor under vacuumed condition.
- 4 Evacuation and Refrigerant charge : Evacuate internal section in the refrigeration system from high and low pressure sides and charge liquid refrigerant from condenser outlet side. Additional charge shall be done with gas condition from low side.
- 5 Do not tilt over the compressor while carrying it.
- 6 Do not remove the paint.
- 7 Crankcase heater is required when the oil sump temperature is too low to meet the requirement of item 6 on page 7.
- 8 Voltage fluctuation between compressor terminals, during operation, shall be within 2% of the rated voltage.
- 9 Do not operate compressor in reverse rotational direction.
- 10 Suction strainers are recommended for all applications.
- 11 Copper Piping Stress

Start/Shutdown	34.32 N/mm ² Max.
Run	12.26 N/mm ² Max.

Section 6. Selection of Electrical Wire

Voltage drop may occur due to the large current draw during compressor starting.

We recommend selecting the wire size from the table below.

6.1 Type of Unit

6.1.1 Window & Commercial Type Unit

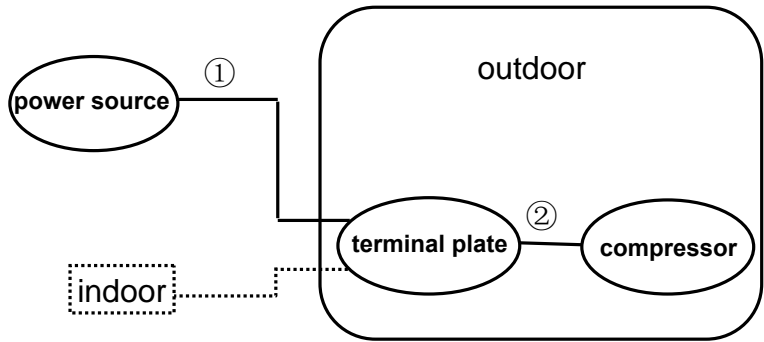

6.1.2 Split Type(Separate Type)

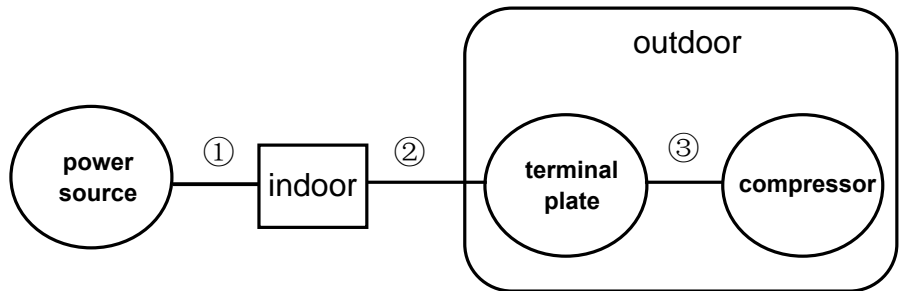

6.2 Size Table of Electrical Wire

Starting current (A)	Size of electrical wire (mm ²)						
	Remark ① or Remark ①+② (heat-resistance Temperature: 60°C(140°F) min.)						Remark③ (heat-resistance Temperature: 120°C(248°F) min.)
	5m max.	10m max.	15m max.	20m max.	30m max.	50m max.	1m max.
20max.	2.0	2.0	2.0	3.5	5.5	8.0	2.0
30max.	↑	↑	3.5	5.5	↑	14.0	↑
40max.	↑	3.5	5.5	↑	8.0	↑	↑
50max.	↑	↑		8.0	14.0	22.0	↑
60max.	↑	5.5	↑	↑			↑
70max.	3.5	↑	8.0	14.0	↑	↑	3.5
80max.	↑	↑			22.0	30.0	↑
90max.	↑	↑	14.0	↑	↑		↑
100max.	↑	8.0	↑	↑		38.0	↑
110max.	↑	↑					↑
120max.	5.5	↑	↑	22.0	30.0	↑	↑
140max.	↑	14.0	↑	↑		50.0	5.5
160max.	↑	↑	22.0	↑	↑		↑
180max.	↑	↑			38.0	60.0	8.0
200max.	8.0	↑	↑	30.0	↑	↑	↑
220max.	↑	↑			50.0	80.0	↑
240max.	↑	↑					14.0

The internal motor protector does not protect the compressor against all possible conditions.

Please be sure that the system utilizes the ground connection when installed in the field.

Section 7. Drawings

7.1. Dimensional Sketch

C-SB Series (3.5HP)

No.	Part Code	Qty	Name
1	809 930 88	1	Compressor
2	A-0101-DSB	1	Terminal Box Cover
3	A-0201-DSB	1	Terminal Box Clip
4	A-0301-DSB	1	Insulating Grommet
5		1	Nameplate
6	B-0101-DSB	1	Screw Special

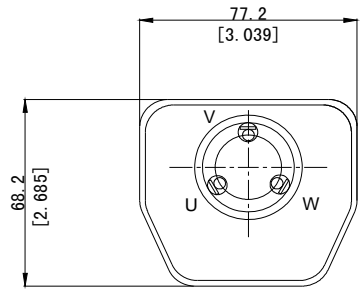
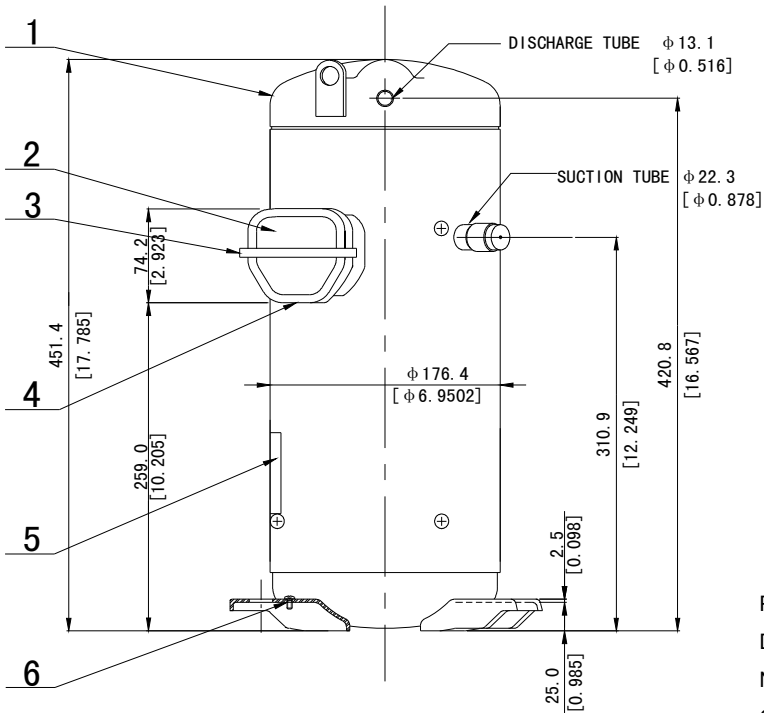
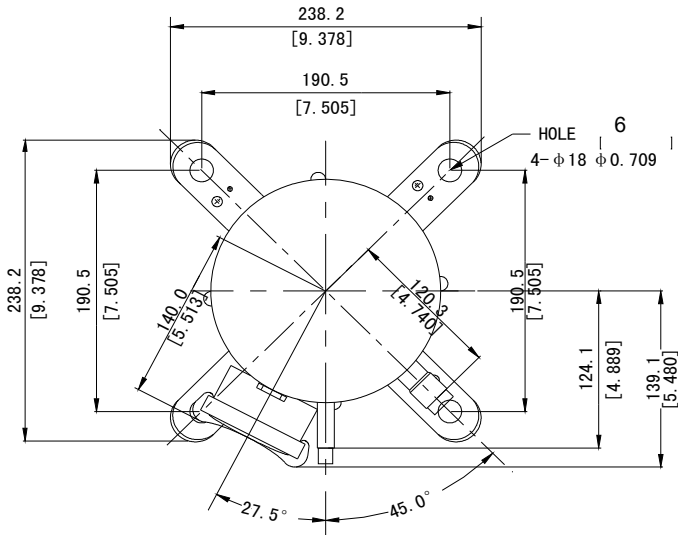

TERMINAL

Part Code
D-0102-DSB
Name
Compressor Outline Drawing

7.2. Wiring & mounting sketch

WIRING DIAGRAM C-SB Series 3phase B8

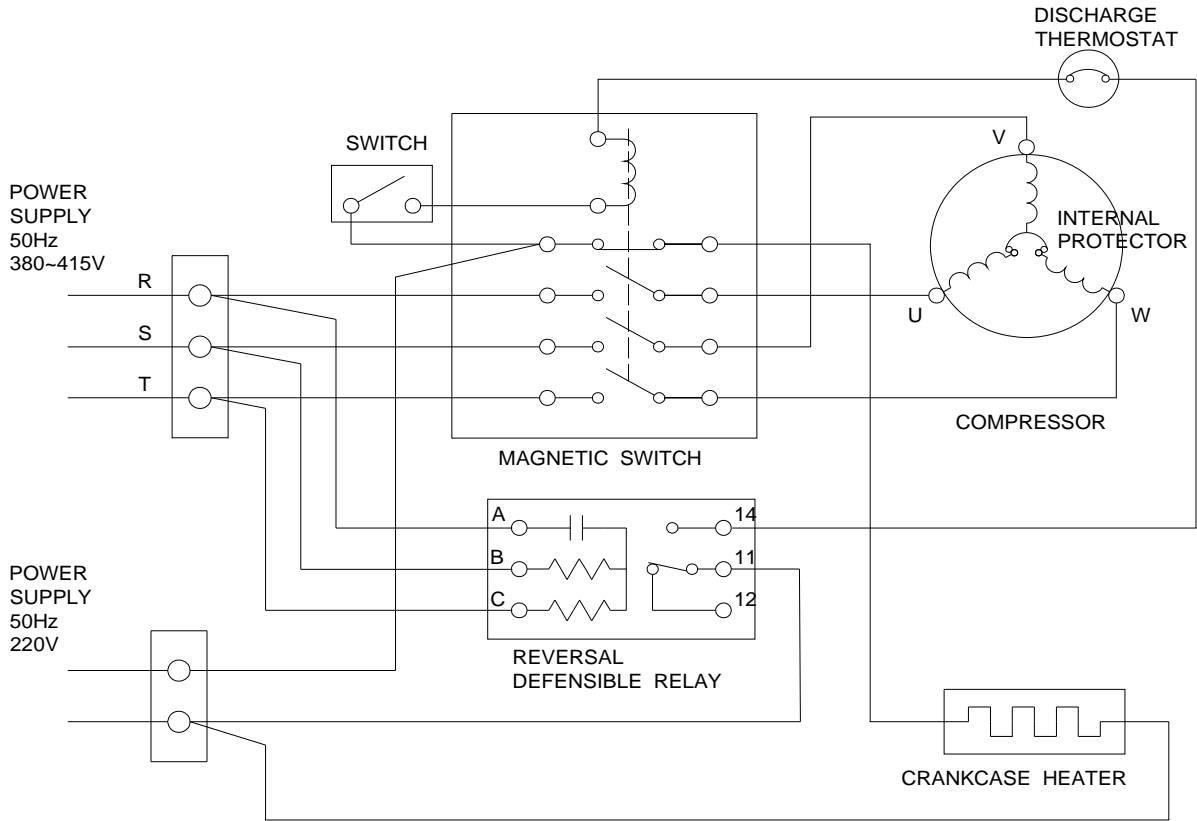

MOUNTING SKETCH

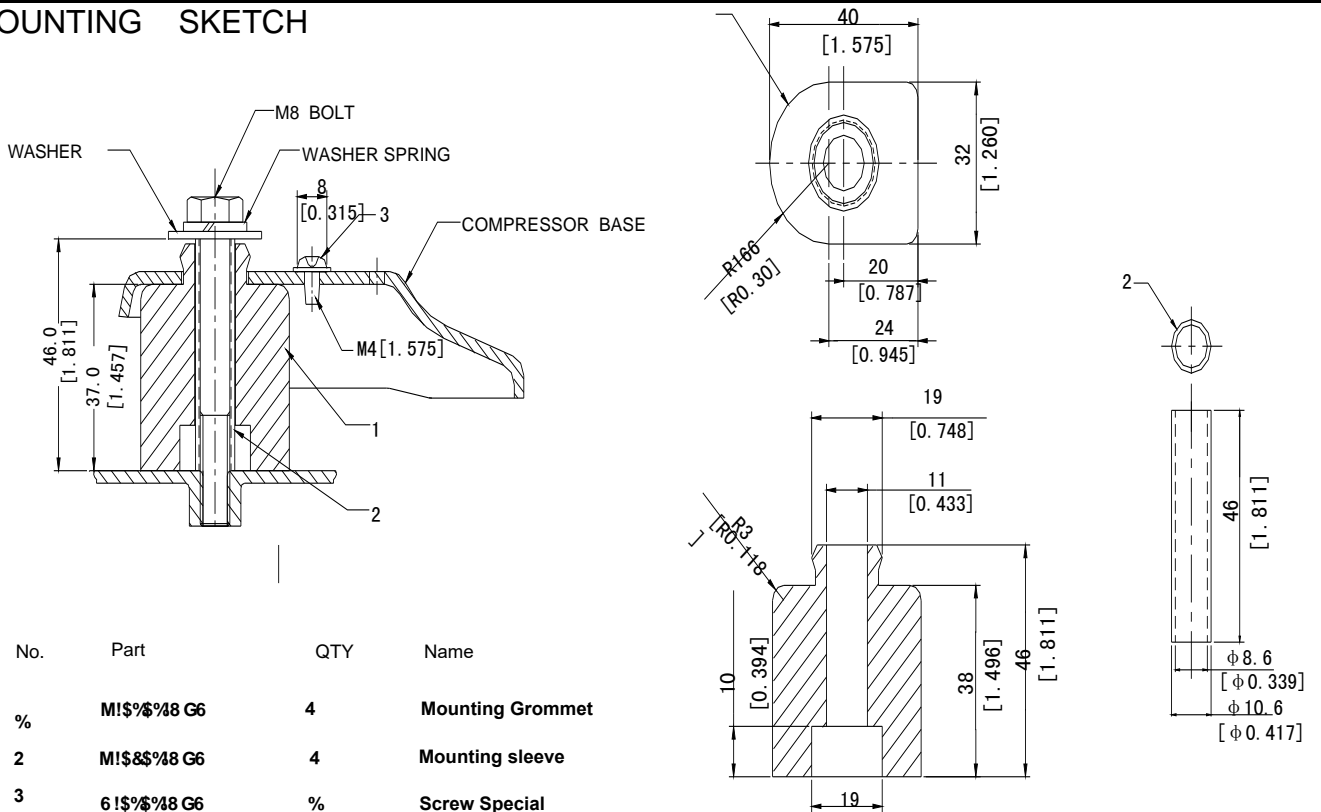

7.2. Packing dimensios

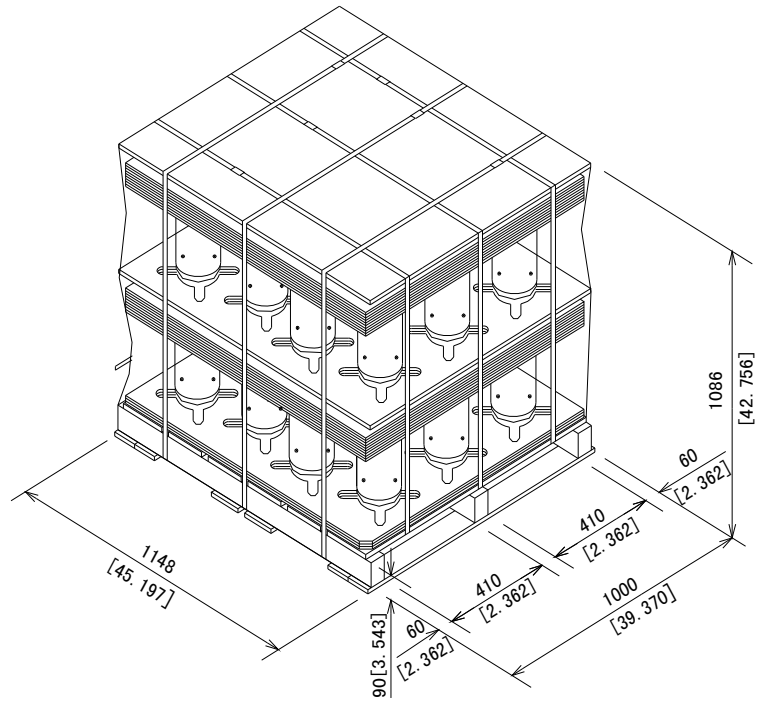
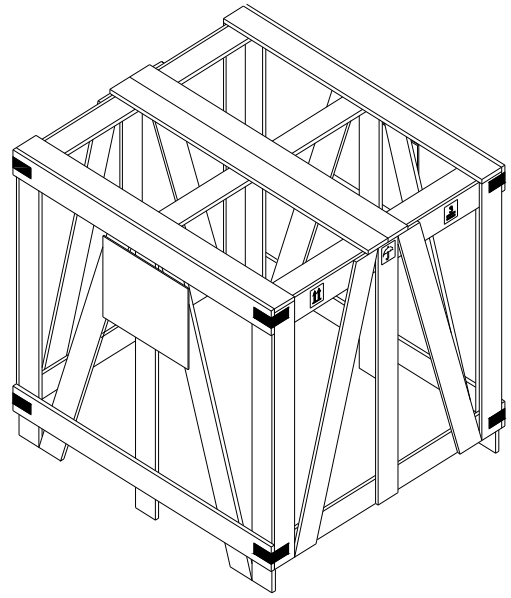
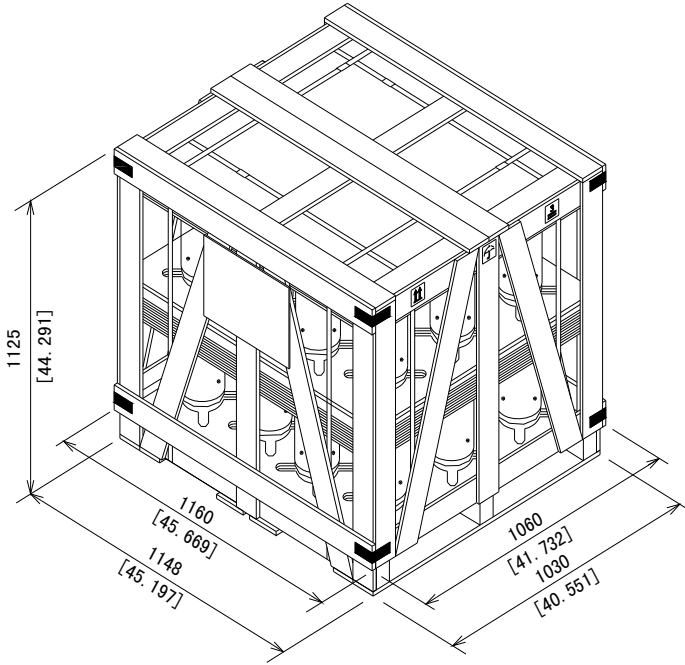

Part Code

D-0201-DSB

Name

Packing Dimensions