

EV3401 Multi-sensor

Universal controllers with one regulation output for industrial applications



PLEASE READ CAREFULLY
and save this document
CONSIDER THE ENVIRONMENT

EN ENGLISH

- power supply 230 VAC or 12-24 VAC/DC (according to the model)
- multi-sensor input (PTC/NTC/J/K/Pt 100/Pt 1000/Ni 120/0-20 mA/4-20 mA/0-10 V/2-10 V)
- multi-purpose input
- K1 relay 16 A res. @ 250 VAC
- alarm buzzer
- TTL MODBUS slave port for programming key or for TTL/RS-485 (BMS) serial interface hot or cold mode regulation.

1 MEASUREMENTS AND INSTALLATION

Measurements in mm (in): 59.0 (2 5/16) depth with fixed screw terminal blocks, 81.5 (3 1/16) depth with plug-in screw terminal blocks. To be fitted to a panel, snap-in brackets provided.

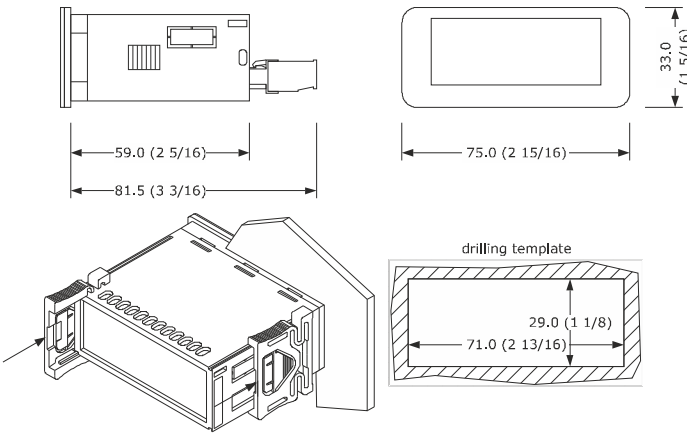

INSTALLATION PRECAUTIONS

- the thickness of the panel must be between 0.8 and 2.0 mm (1/32 and 1/16 in); ensure that the working conditions are within the limits stated in the *TECHNICAL SPECIFICATIONS* section;
- do not install the device close to heat sources, equipment with a strong magnetic field, in places subject to direct sunlight, rain, damp, excessive dust, mechanical vibrations or shocks;
- in compliance with safety regulations, the device must be installed properly to ensure adequate protection from contact with electrical parts. All protective parts must be fixed in such a way as to need the aid of a tool to remove them.

2 ELECTRICAL CONNECTION

- N.B.**
- use cables of an adequate section for the current running through them.
 - ensure that the thermocouple is properly insulated from contact with metal parts or use already insulated thermocouples.
 - if necessary, extend the thermocouple cable using a compensating cable.
 - to reduce any electromagnetic interference locate the power cables as far away as possible from the signal cables.

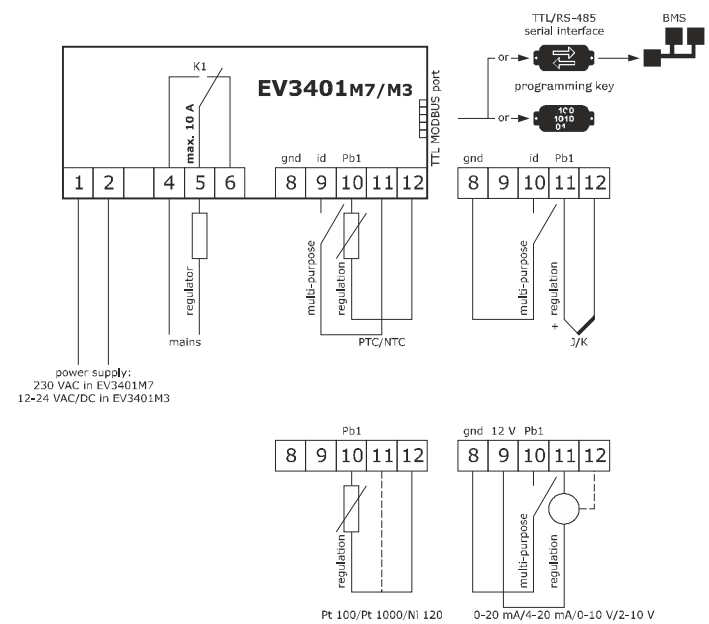

PRECAUTIONS FOR ELECTRICAL CONNECTION

- if using an electrical or pneumatic screwdriver, adjust the tightening torque;
- if the device has been moved from a cold to a warm place, humidity may have caused condensation to form inside. Wait about an hour before switching on the power;
- make sure that the supply voltage, electrical frequency and power are within the set limits. See the section *TECHNICAL SPECIFICATIONS*;
- disconnect the power supply before carrying out any type of maintenance;
- do not use the device as safety device;
- for repairs and for further information, contact the EVCO sales network.

3 FIRST-TIME USE

1. Install following the instructions given in the section *MEASUREMENTS AND INSTALLATION*.
2. Power up the device as set out in the section *ELECTRICAL CONNECTION*: an internal test will start up. The test normally takes a few seconds; when it is finished the display will switch off.
3. Configure the device as shown in the section *Setting configuration parameters*. Recommended configuration parameters for first-time use.

PAR.	DEF.	PARAMETER	MIN... MAX.
SP	0.0	setpoint	r1... r2
PO	2	type of probe set the parameter before connecting the probe	0 = PTC 1 = NTC 2 = J 3 = K 4 = Pt 100 3 wires 5 = Pt 100 3 wires 6 = Pt 1000 3 wires 7 = Pt 1000 3 wires 8 = 4-20 mA 9 = 0-20 mA 10 = 2-10 V 11 = 0-10 V 12 = Ni 120 3 wires 13 = Ni 120 2 wires
P2	0	temperature measurement unit	0 = °C 1 = °F
r5	0	hot or cold mode regulation regulator	0 = cold mode 1 = hot mode

Then check that the remaining settings are appropriate; see the section *CONFIGURATION PARAMETERS*.

4. Disconnect the device from the mains.
5. Make the electrical connection as shown in the section *ELECTRICAL CONNECTION* without powering up the device.
6. When connecting to an RS-485 network, connect the EVIF22TSX interface; see the relative instruction sheets.

7. Power up the device.

4 USER INTERFACE AND MAIN FUNCTIONS

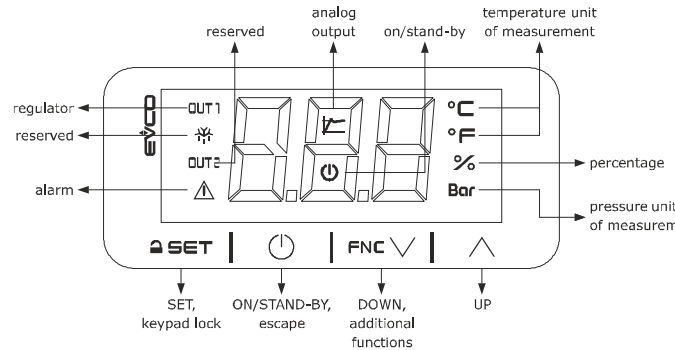

4.1 Switching the device on/off

1. If POF = 1 (default), touch the ON/STAND-BY key for 4s.

If the device is switched on, the display will show the P5 value ("regulation temperature" default); if the display shows an alarm code, see the section *ALARMS*.

LED	ON	OFF	FLASHING
OUT1	regulator active	-	- regulator protection active - setpoint being set
☀	unused	-	-
OUT2	unused	-	-
⚠	alarm active	-	-
⏻	unused	-	-
⏻	device switched off	device switched on	device being switched on/off
°C/°F	temperature display	-	-
%	percentage display	-	-
Bar	pressure display	-	-

When 30s have elapsed without the keys being pressed, the display will show the "Loc" label and the keypad will lock automatically.

4.2 Unlocking the keypad

Touch a key for 1s: the display will show the label "UnL".

4.3 Setting the setpoint

Check that the keypad is not locked.

1. Touch the SET key: the display will show the label "SP".
2. Touch the UP or DOWN key within 15s to set the value within the limits r1 and r2 (default "0... 350").
3. Touch the SET key (or take no action for 15s).

4.4 Silencing the buzzer (if A13 = 1)

Touch a key.

5 FUNCTION MODES

Cold mode regulation (r5 = 0).

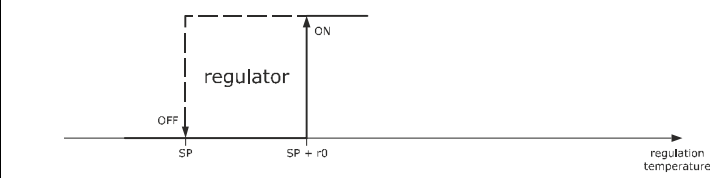

Hot mode regulation (r5 = 1).

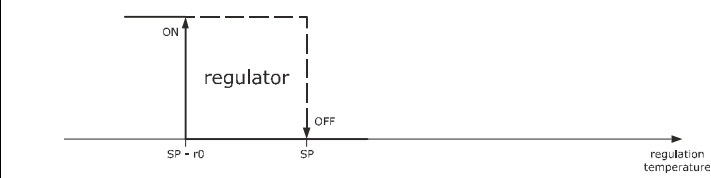

6 ADDITIONAL FUNCTIONS

6.1 Displaying the number of start-ups of the relay

Check that the keypad is not locked.

1. Touch the DOWN key for 4s.
2. Touch the UP or DOWN key within 15s to select a label.

LAB.	DESCRIPTION
nS1	display of the number of start-ups of the K1 relay in thousands

3. Touch the SET key.
4. Touch the ON/STAND-BY key (or take no action for 60s) to exit the procedure.

6.2 Displaying the temperature detected by the regulation probe

Check that the keypad is not locked.

1. Touch the DOWN key for 4s.
2. Touch the UP or DOWN key within 15s to select a label.

LAB.	DESCRIPTION
Pb1	regulation temperature

3. Touch the SET key.
4. Touch the ON/STAND-BY key (or take no action for 60s) to exit the procedure.

7 SETTINGS

7.1 Setting configuration parameters

- N.B.**
Changing parameter P2 from °C to °F (and vice versa) causes the value of the parameters whose unit of measurement is °C or °F to be changed automatically.

1. Touch the SET key for 4s: the display will show the label "PA".
2. Touch the SET key.
3. Touch the UP or DOWN key within 15s to set the PAS value (default "-19").
4. Touch the SET key (or take no action for 15s): the display will show the label "SP".
5. Touch the UP or DOWN key to select a parameter.

6. Touch the SET key.
7. Touch the UP or DOWN key within 15s to set the value.
8. Touch the SET key (or take no action for 15s).
9. Touch the SET key for 4s (or take no action for 60s) to exit the procedure.

7.2 Restoring factory settings (default) and saving customised settings

- N.B.**
- Check that the factory settings are appropriate; see the section *CONFIGURATION PARAMETERS*.
 - Saving customised settings overwrites the factory settings.

1. Touch the SET key for 4s: the display will show the label "PA".
2. Touch the SET key.
3. Touch the UP or DOWN key within 15s to set the value.

VAL.	DESCRIPTION
149	value for restoring the factory information (default)
161	value for saving customised settings

4. Touch the SET key (or take no action for 15s): the display will show the label "dEF" (for setting the "149" value) or the label "MAP" (for setting the "161" value).
5. Touch the SET key.
6. Touch the UP or DOWN key within 15s to set "4".
7. Touch the SET key (or take no action for 15s): the display will show "- - -" flashing for 4s, after which the device will exit the procedure.
8. Disconnect the device from the power supply.
9. Touch the SET key for 2s before action 6 to exit the procedure beforehand.

8 CONFIGURATION PARAMETERS

N.	PAR.	DEF.	SETPOINT	MIN... MAX.
1	SP	0.0	setpoint	r1... r2
2	CA1	0.0	regulation probe offset	-25... 25 °C/°F
3	PO	2	type of probe	0 = PTC 1 = NTC 2 = J 3 = K 4 = Pt 100 3 wires 5 = Pt 100 2 wires 6 = Pt 1000 3 wires 7 = Pt 1000 2 wires 8 = 4-20 mA 9 = 0-20 mA 10 = 2-10 V 11 = 0-10 V 12 = Ni 120 3 wires 13 = Ni 120 2 wires
4	P1	0	enable decimal point °C	0 = no 1 = yes if PO = 2 or 3, not effective if PO = 8... 11, position of decimal point: 0 = none 1 = tens digit
5	P2	0	measurement unit	0 = °C 1 = °F 2 = % 3 = bar 4 = none options 2... 4 effective only on LEDs and if PO = 8... 11
6	P3	0.0	minimum transducer calibration value	-199... 999 points
7	P4	100	maximum transducer calibration value	-199... 999 points
8	P5	0	value displayed	0 = regulation temperature 1 = setpoint
9	P8	5	display refresh time	0... 250 s : 10
10	r0	2.0	setpoint differential	1... 99 °C/°F
11	r1	0.0	minimum setpoint	-199 °C/°F... r2
12	r2	350	maximum setpoint	r1... 999 °C/°F
13	r5	0	hot or cold mode regulation regulator	0 = cold mode 1 = hot mode
14	r11	0.0	digital input second setpoint	-199... 999 °C/°F setpoint + r11
15	C1	0	minimum time between two power-ons of regulator	0... 240 min
16	C2	0	minimum time off and delay from power-on of regulator	0... 240 min
17	C3	0	minimum time on regulator	0... 240 s
18	C4	0	regulator activity during regulation probe alarm	0 = off 1 = on
19	A1	0.0	temperature alarm threshold	-199... 999 °C/°F
20	A2	0	temperature alarm type	0 = disabled 1 = absolute minimum 2 = absolute maximum 3 = minimum relative to SP 4 = maximum relative to SP
21	A3	0	temperature alarm delay	0... 999 min
22	A7	0	temperature alarm delay after modifying setpoint and power-on	0... 999 min
23	A8	0	additional alarm signal delay after silencing if the condition persists	0... 999 min
24	A11	2.0	temperature alarm switch off differential	1... 99 °C/°F
25	A13	1	enable alarm buzzer	0 = no 1 = yes
26	i5	0	multi-purpose input function	0 = disabled 1 = alarm iA 2 = alarm iA + regulator off 3 = switches device on/off 4 = modifies setpoint
27	i6	0	multi-purpose input activation	0 = with contact closed 1 = with contact open
28	i7	0	multi-purpose input alarm delay	0... 999 s
29	POF	1	enable ON/STAND-BY key	0 = no 1 = yes
30	PAS	-19	password	-99... 999
31	LA	247	MODBUS address	1... 247
32	Lb	3	MODBUS baud rate	0 = 2,400 baud 1 = 4,800 baud 2 = 9,600 baud 3 = 19,200 baud even

9 ALARMS

COD.	DESCRIPTION	RESET	TO CORRECT
Pr1	regulation probe alarm	automatic	- check P0 - check probe integrity - check electrical connection
AL	temperature alarm	automatic	check A1, A2 and A3
IA	multi-purpose input alarm	automatic	check i5 and i6

10 TECHNICAL SPECIFICATIONS

Purpose of the control device		Operating control
Construction of the control device		Incorporated control
Container		Black, self-extinguishing
Category of heat and fire resistance		D
Measurements		
75.0 x 33.0 x 59.0 mm (2 15/16 x 1 5/16 x 2 5/16 in) with fixed screw terminal blocks		75.0 x 33.0 x 81.5 mm (2 15/16 x 1 5/16 x 3 3/16 in) with plug-in screw terminal blocks
Mounting methods for the control device		To be fitted to a panel, snap-in brackets provided
Degree of protection provided by the covering		IP65 (front)
Connection method		
Fixed screw terminal blocks for wires up to 2.5 mm ²	Plug-in screw terminal blocks for wires up to 2.5 mm ² (on request)	Pico-Blade connector
Maximum permitted length for connection cables		
Power supply: 10 m (32.8 ft)	Analogue inputs: 10 m (32.8 ft)	
Digital inputs: 10 m (32.8 ft)	Digital outputs: 10 m (32.8 ft)	
Operating temperature	From -5 to 55 °C (from 23 to 131 °F)	
Storage temperature	From -40 to 70 °C (from -40 to 158 °F)	
Operating humidity	Relative humidity without condensate from 10 to 90%	
Pollution status of the control device		2
Compliance:		
RoHS 2011/65/EC	WEEE 2012/19/EU	REACH (EC) Regulation 1907/2006
EMC 2014/30/EU	LVD 2014/35/EU	
Power supply:		
230 VAC (+10% -15%), 50/60 Hz (±3 Hz), max. 4 VA in EV3... M7		
12-24 VAC/DC (+10% -15%), 50/60 Hz (±3 Hz), max. 5 VA/3W in EV3... M3		
Earthing methods for the control device		None
Rated impulse-withstand voltage		2.5 KV
Over-voltage category		II
Software class and structure		A
Analogue inputs		1 for PTC, NTC, Pt 100, Pt 1000 or Ni 120 probes, J or K thermocouples, 0-20 mA, 4-20 mA, 0-10 V or 2-10 V transducers (regulation probe)
PTC probes	Measurement field:	from -50 to 150 °C (from -58 to 302 °F)
	Resolution:	0.1 °C (1 °F)
NTC probes	Measurement field:	from -40 to 110 °C (from -58 to 230 °F)
	Resolution:	0.1 °C (1 °F)
Pt 100 and Pt 1000 probes	Measurement field:	from -100 to 650 °C (from -148 to 999 °F)
	Resolution:	0.1 °C (1 °F)
Ni 120 probes	Measurement field:	from -80 to 300 °C (from -112 to 999 °F)
	Resolution:	0.1 °C (1 °F)
J thermo-couples	Measurement field:	from 0 to 700 °C (from 32 to 999 °F)
	Resolution:	1 °C (1 °F)
K thermo-couples	Measurement field:	from 0 to 999 °C (from 32 to 999 °F)
	Resolution:	1 °C (1 °F)
0-20 mA, 4-20 mA, 0-10 V and 2-10 V transducers:		can be configured
Digital inputs		1 dry contact (multi-purpose), not available if the analogue input is configured for Pt 100, Pt 1000 or Ni 120 3 wires
Dry contact	Contact type:	3.3 V, 1 mA
	Protection:	none
Digital outputs		1 with electromechanical relay (K1 relay)
K1 relay		SPDT, 16 A res. @ 250 VAC
Type 1 or Type 2 Actions		Type 1
Additional features of Type 1 or Type 2 actions		C
Displays		LED display, 3 digit, with function icons
Alarm buzzer		Built-in
Communications ports		1 TTL MODBUS slave port for programming key or for serial interface (BMS)

 N.B.
The device must be disposed of according to local regulations governing the collection of electrical and electronic equipment.

This document and the solutions contained therein are the intellectual property of EVCO and thus protected by the Italian Intellectual Property Rights Code (CPI). EVCO imposes an absolute ban on the full or partial reproduction and disclosure of the content other than with the express approval of EVCO. The customer (manufacturer, installer or end-user) assumes all responsibility for the configuration of the device.
EVCO accepts no liability for any possible errors in this document and reserves the right to make any changes, at any time without prejudice to the essential functional and safety features of the equipment.