

浙江麦迪制冷科技股份有限公司

Zhejiang Maida Refrigeration Technology Co., Ltd

全封闭制冷压缩机规格书

HERMETIC REFRIGERATION COMPRESSOR

压缩机型号：GQR70TG

COMPRESSOR MODEL : GQR70TG

编制：

EDITOR

钱志刚

审核：

CHECK

周 旭

批准：

APPROVAL

李 毅

压缩机特性规格书

PERFORMANCE FOR COMPRESSOR

机型 (MODEL): GQR70TG

1PH, 50Hz, 220-240V

1、适用范围 (APPLICATION)

蒸发温度范围 (EVAPORATING TEMP RANGE)	-15~+10℃
冷却方式 (COOLING TYPE)	风冷 (F)
制冷控制 (REFRIGERATION CONTROL)	毛细管 (CAPILLARY)
认证种类 (APPROVAL)	CCC、CB、CE
电压范围 (VOLTAGE RANGE)	220~240V
冷媒 (REFRIGERANT)	R134a

2、额定性能及测试条件 (RATED PERFORMANCE AND TEST CONDITIONS)

制冷能力 (COOLING CAPACITY)	725 (W)
输入功率 (INPUT POWER)	315 (W)
额定电流 (RATED CURRENT)	1.75(A)
能效比 (EFFICIENCY) COP	2.30(W/W)
测试工况 (ASHRAE TEST CONDITION)	中/高背压 (M/HBP)
测试电源 (TEST POWER SOURCE)	220V~50Hz 1PH
蒸发温度 (EVAPORATING TEMP)	+7.2℃
冷凝温度 (CONDENSING TEMP)	54.4℃
吸气温度 (SUNCTION TEMP)	35.0℃
过冷温度(SUBCOOLING TEMP)	46.1℃
环境温度 (AMBIENT TEMP)	35.0℃

压缩机特性规格书

PERFORMANCE FOR COMPRESSOR

机型 (MODEL): GQR70TG

1PH, 50Hz, 220-240V

3、主要构造项目 (MAIN STRUCTURE)

压缩机类型 (COMPRESSOR TYPE)	全封闭型电动压缩机 (HERMTIC MOTOR-COMPRESSOR)
泵体类型 (PUMP TYPE)	往复式 (RECIPROCATING TYPE)
冷冻机油类型(OIL TYPE)	脂类油 22#
冷冻机油充注量(OIL CHARGE)	180ml
涂装(PAINTING)	黑色涂装, 烘烤干燥 (BLACK PAINT,BAKED)
净重(NET WEIGHT)	6.8Kg
吸气管内径(ID OF SUCTION TUBE)	Ø6.2±0.1
排气管内径(ID OF DISCHARGE TUBE)	Ø5.1±0.1
工艺管内径(ID OF PROCESS TUBE)	Ø6.2±0.1
残余杂质 (RESIDUAL IMPURITIES)	80mg MAX
残余水分 (RESIDUAL MOISTURE)	130mg MAX

4、电机 (MOTOR)

启动方式 (STARTING TYPE)	CSIR(PTC)
电压范围 (VOLTAGE RANGE)	187~242V
绝缘等级 (INSULATION GRADE)	B GRADE
堵转电流 (LOCKED ROTOR CURRENT)	9.0A

压缩机特性规格书

PERFORMANCE FOR COMPRESSOR

机型 (MODEL): GQR70TG

1PH, 50Hz, 220-240V

5、电器元件 (ELECTRICAL COMPONENTS)

热保护 (THERMAL PROTECTOR)	
型号 (TYPE)	GQR70TG
动作温度 (TRIP TEMP)	130±5℃
复位温度 (RESET TEMP)	61±7℃
最小动作电流 (U.T.C) 75℃	2.4A
断开电流 (TURN-OFF CURRENT) 25℃	9.0A
动作时间 (TRIP TIME)	7-14sec
启动器 (STARTING RELAY)	
型号 (TYPE)	QP2-15
电阻 (RESISTANCE)	15 ± 5%Ω
复位时间 (RESET TIME)	80sec MAX
运行电容 (RUNNING CAPACITOR)	
型号 (TYPE)	/
电容值 (CAPACITY VALUE) 25℃	/
启动电容 (STARTING CAPACITOR)	
型号 (TYPE)	CD60
电容值 (CAPACITY VALUE) 25℃	60μF 330VAC 50/60Hz

压缩机规格书及附件清单

LIST OF COMPRESSOR & ACCESSORIES

机型 (MODEL): GQR70TG

1PH, 50Hz, 220-240V

6、附件清单 (ACCESSORIES LIST)

名称 (NAME)	规格(DESCRIPTION)	数量 (QTY)
热保护 (THERMAL PROTECTOR)	GQR70TG	1
启动器 (STARTING RELAY)	QP2-15	1
运行电容 (RUNNING CAPACITOR)	/	/
启动电容 (STARTING CAPACITOR)	60 μ F	1
电机罩壳 (ELECTRICAL COVER)		1
罩壳卡簧 (COVER CLAMP)		1
减震胶座 (RUBBER GROMMET)		4
安装套管 (BUSHING)		4

7、接线方式 (ELECTRICAL WIRING DIAGRAM)

CSIR

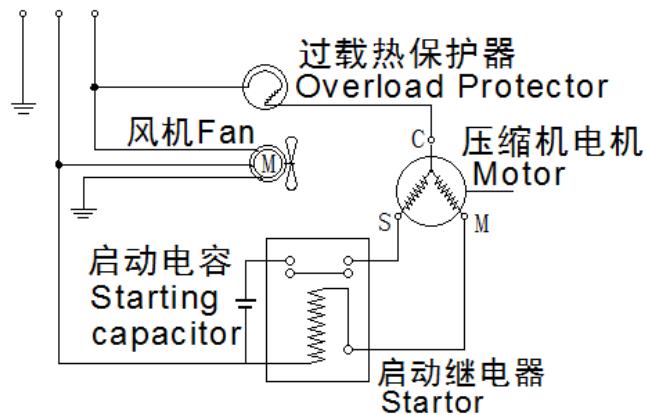

压缩机外形尺寸图

DIMENSIONS FOR COMPRESSOR

机型 (MODEL): GQR70TG

1PH, 50Hz, 220-240V

8、压缩机外形图 (DIMENSIONS FOR COMPRESSOR) :

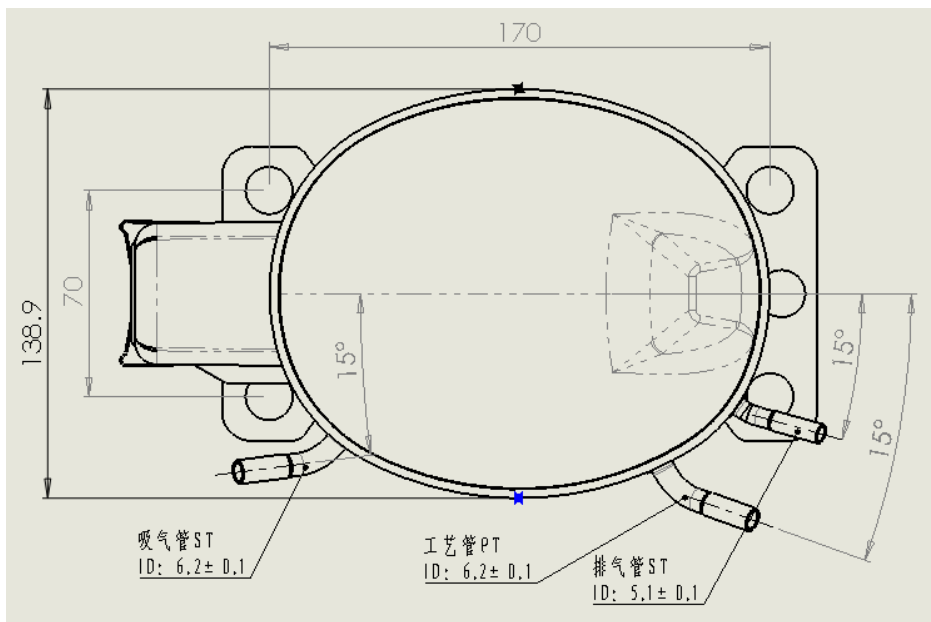
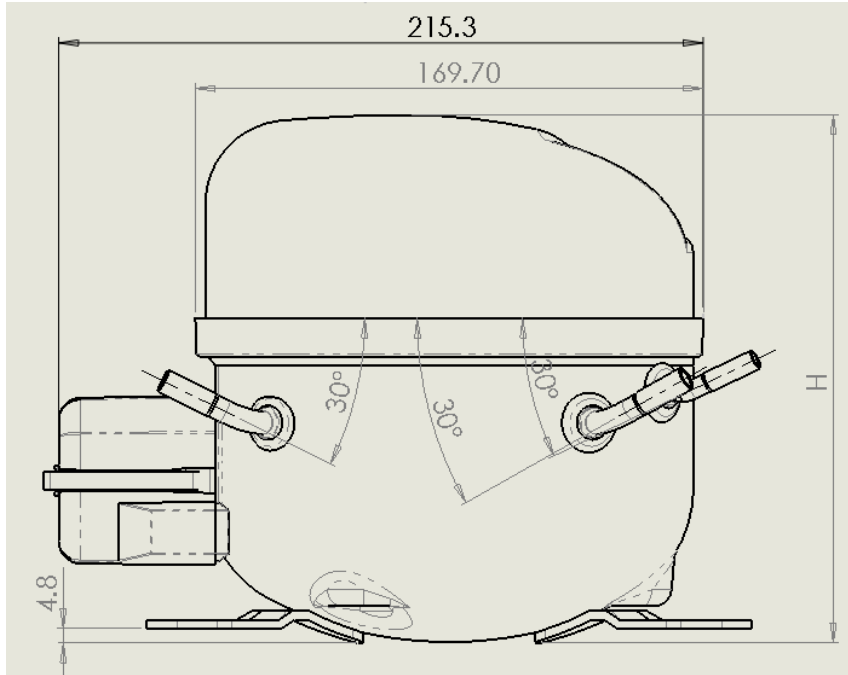

压缩机高度 Height value of compressor: $H=178 \pm 2\text{mm}$.

压缩机安装示意图

MOUNTING DIAGRAM FOR COMPRESSOR

机型 (MODEL): GQR70TG

1PH, 50Hz, 220-240V

9、安装图 (MOUNTING DIAGRAM FOR COMPRESSOR)

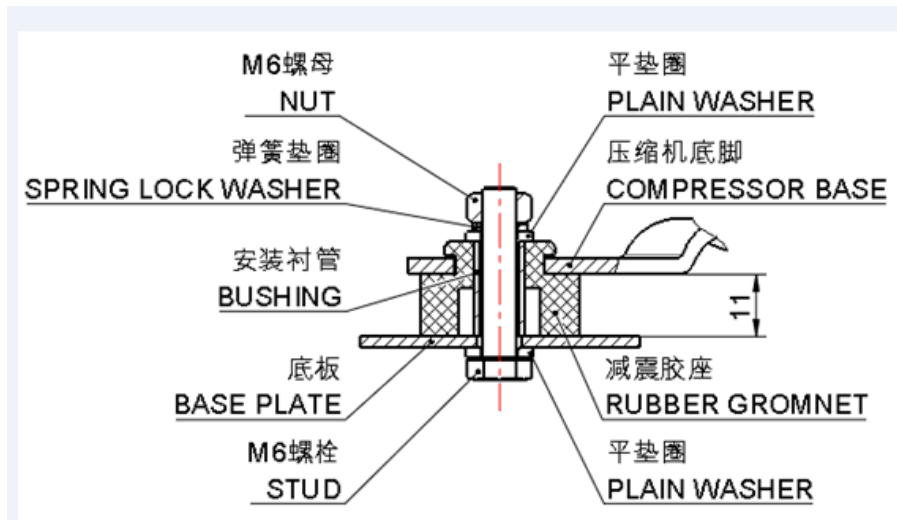

安装方式 (MOUNTING TYPE) :(1)

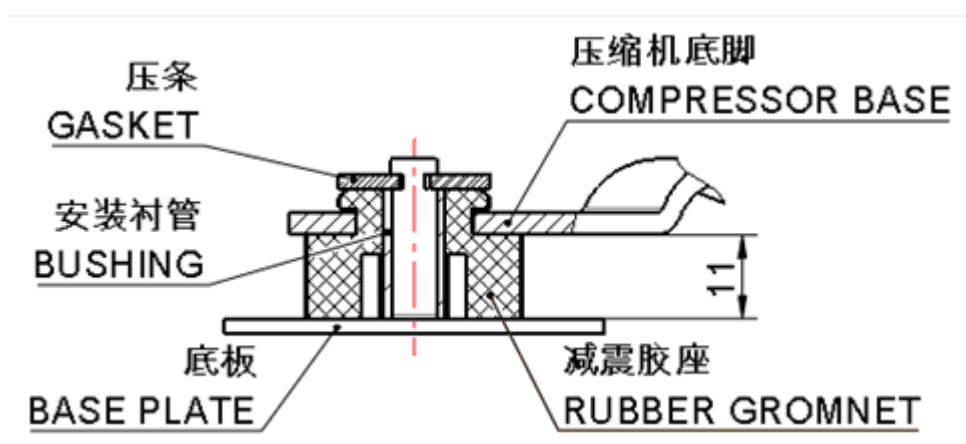

安装方式 (MOUNTING TYPE) :(2)

压缩机装运条件

TRANSPORTATION FOR COMPRESSOR

机型 (MODEL): GQR70TG

1PH, 50Hz, 220-240V

10、包装、贮存和运输 (TRANSPORTATION FOR COMPRESSOR)

包装类型(Packing type)	一次性 (不返用) (Disposable)
运输(Transport)	火车或汽车(Train, bus, vessel)
堆码层数(Stacking layers)	最多两层(not more than two layers)
型号(Model)	GQR70TG
搬运(Moving)	保持压缩机正常和垂直状态(Keep the compressor normal and vertical status)