



FRIO[®]

Scroll Kompressörler



FRIO®



Scroll Kompresörler

R407C GAZI İÇİN WR SERİSİ

R404A GAZI İÇİN WB SERİSİ



Sütlük ve market tip buzdolapları



Soğuk Odalar



Hava Kurutucular



Chiller ve Endüstriyel Tip Soğutma Cihazları



Süt Tankları

İÇİNDEKİLER:

Model Adlandırma	— 3
WB Serisi Scroll Kompresörler İçin Teknik Özellikler	— 4-5
WB Serisi Scroll Kompresörler İçin Kapasite Tablosu	— 6
WB Serisi Scroll Kompresörler İçin Teknik Çizimler	— 7-8
WR Serisi Scroll Kompresörler İçin Teknik Özellikler	— 9-10
WR Serisi Scroll Kompresörler İçin Kapasite Tablosu	— 11
WR Serisi Scroll Kompresörler İçin Teknik Çizimler	— 12-14

Adlandırma

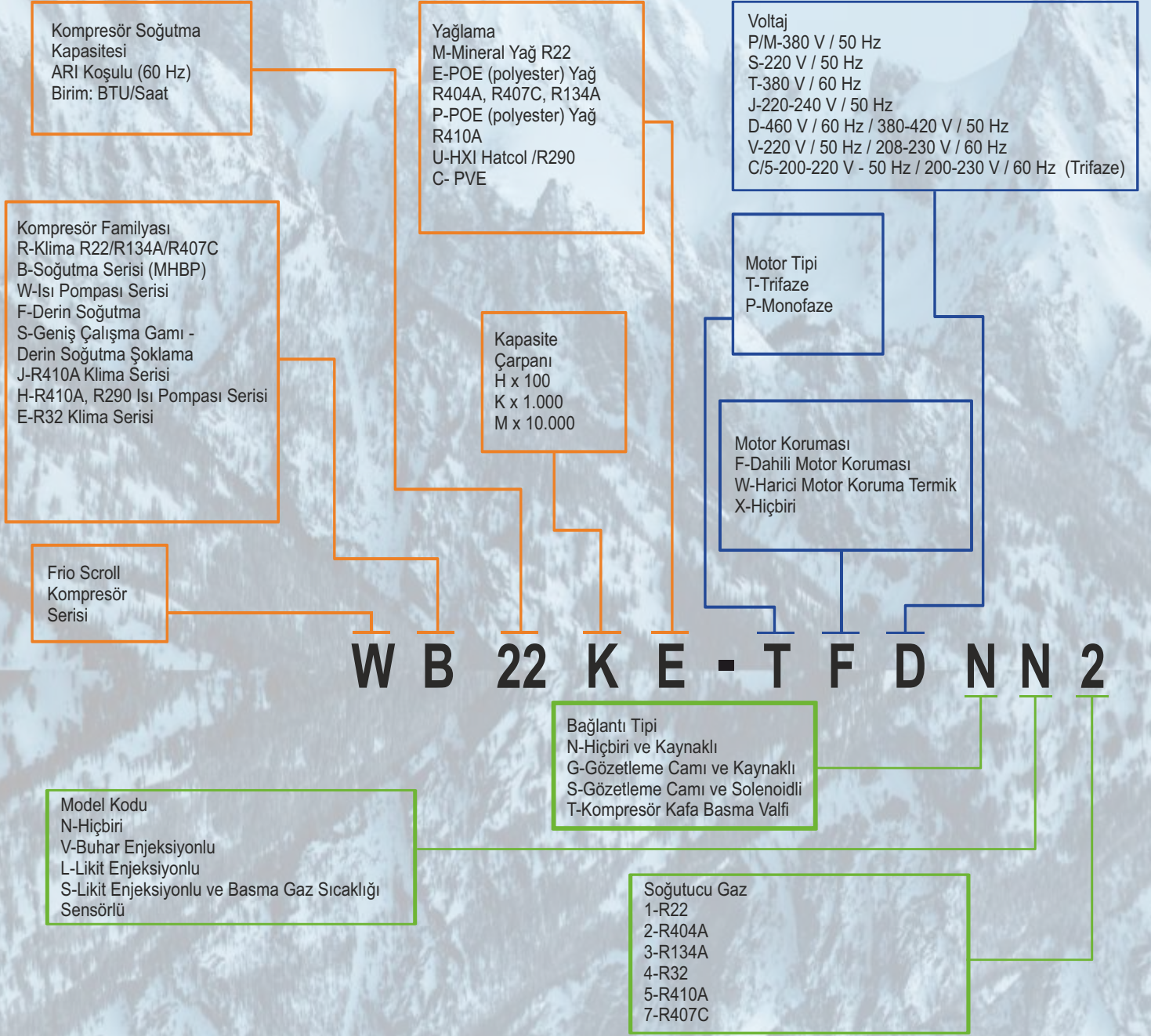

Çalışma Zarfları

WB Serisi Orta ve Yüksek Sıcaklık (MHBP)

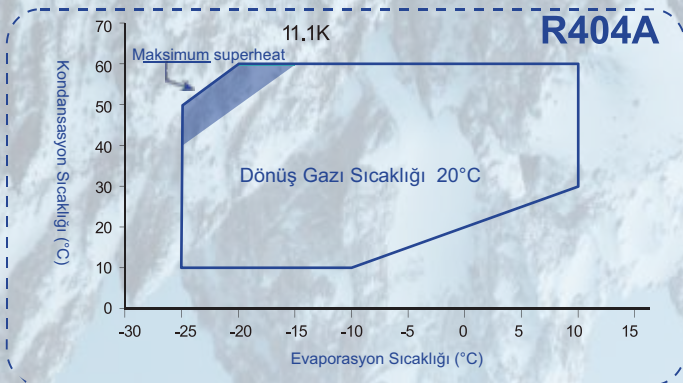

WF Serisi Derin Soğutma (LBP)

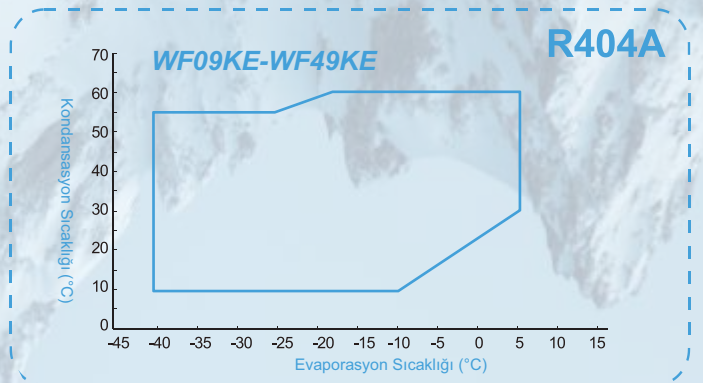

Model		WB15KE-PFJ	WB15KE-TFD	WB19KE-TFD	WB22KE-TFD	WB29KE-TFD	WB40KE-TFD	WB45 KE-TFD
Motor Voltajı		220-240V/50Hz/1ph	380-420V/50Hz/3ph					
Güç (hp)		2	2	2.5	3	4	5	6
Silindir Hacmi (m3/saat)		5.7	5.7	6.6	8.4	11.6	14.7	17.7
Soğutucu Gaz		R404A	R404A	R404A	R404A	R404A	R404A	R404A
Nominal Soğutma Kapasitesi (W)		3200	3200	3550	4500	6500	7560	8600
Giriş Gücü (W)		1542	1540	1690	2330	2950	3550	3950
COP (W/W)		2.07	2.07	2.11	1.93	2.2	2.12	2.17
Nominal Çalışma Akımı (A)		11.4	4.2	4.5	5.8	7.3	9.4	11.6
LRA (A)		58	26	32	46	60	66	81
Maksimum Çalışma Akımı (A)		15	5.8	6	8	10	13	16
Giriş Çıkış	Basma Hattı	1/2	1/2	1/2	1/2	1/2	1/2	1/2
	Ölçüleri	Emme Hattı	3/4	3/4	3/4	3/4	7/8	7/8
Ölçüler (mm)	En x Boy x Yükseklik	240x240x381,5	240x240x381,5	240x240x381,5	240x240x404,5	240x240x435,5	245x245x455,8	240x240x456
Montaj Ölçüsü (Çap) (mm)		190X190(Ø8.5)						
Yağ Tipi		POE						
Yağ İlk Şarj Miktarı (lt)		1.22	1.22	1.35	1.43	1.35	2.03	1.92
Tekrar Dolun Yağ Miktarı (lt)		1.22	1.22	1.35	1.43	1.35	2.03	1.92
Maksimum Çalışma Basıncı	Yüksek Basınç Tarafı	3.0	3.0	3.0	3.0	3.0	3.0	3.0
	Alçak Basınç Tarafı	2.0	2.0	2.0	2.0	2.0	2.0	2.0
Ağırlık (kg)		23.5	23.5	24.7	26.8	33.6	38.4	40.5
Karter Isıtıcısı Gücü (W)		70						

Not: Evaporasyon sıcaklığı -6,7°C, Kondansasyon sıcaklığı 48,9°C, Dönüş gazı sıcaklığı 4,4°C'dir.

Kondansasyon "Subcooling" 0°C.

WB Serisi Orta ve Yüksek Sıcaklık

Model		WB48 KE-TFD	WB58 KE-TFD	WB66 KE-TFD	WB76 KE-TFD	WB89 KE-TFD	WB96 KE-TFD	WB110 KE-TFD
Motor Voltajı		380~420V/50Hz/3ph				420V/50Hz/3ph		
Güç (hp)		7	8	9	10	12	13	15
Silindir Hacmi (m3/saat)		19.4	22.9	26.2	29.5	34.3	36.3	42.8
Soğutucu Gaz		R404A	R404A	R404A	R404A	R404A	R404A	R404A
Nominal Soğutma Kapasitesi (W)		9500	11800	14900	17200	18450	21300	23000
Giriş Gücü (W)		4550	5600	7090	7450	7495	9500	11310
COP (W/W)		2.08	2.1	2.1	2.3	2.46	2.24	2.03
Nominal Çalışma Akımı (A)		12.3	16	17.9	19.5	21.7	23.7	27.2
LRA (A)		110	117	120	122	129	149	188
Maksimum Çalışma Akımı		17	22	25	27	30	32	37
Giriş Çıkış Ölçüleri	Basma Hattı	3/4	7/8	7/8	7/8	7/8	7/8	7/8
	Emme Hattı	7/8	1 1/8	1 3/8	1 3/8	1 3/8	1 3/8	1 3/8
Ölçüler (mm)	En x Boy x Yükseklik	240x240x456	240x240x461	260x280x551	260x280x551	260x280x551	260x280x570	260x280x570
Montaj Ölçüsü (Çap) (mm)		190X190(Ø8.5)						
Yağ Tipi		POE						
Yağ İlk Şarj Miktarı (lt)		1.78	2.49	2.49	3.23	3.23	3.25	3.25
Tekrar Dolum Yağ Miktarı (lt)		1.78	2.49	3.23	3.23	3.23	3.25	3.25
Maksimum Çalışma Basıncı	Yüksek Basınç Tarafı	3.0	3.0	3.0	3.0	3.0	3.0	3.0
	Alçak Basınç Tarafı	2.0	2.0	2.0	2.0	2.0	2.0	2.0
Ağırlık (kg)		40.9	58.1	60.2	62.5	62.7	62.8	67.1
Karter Isıtıcısı Gücü (W)		90						

Not: Evaporasyon sıcaklığı -6,7°C, Kondansasyon sıcaklığı 48,9°C, Dönüş gazı sıcaklığı 4,4°C'dir.

Kondansasyon "Subcooling" 0°C.

R404A

WB Serisi Orta ve Yüksek Sıcaklık

Model	Kondansasyon Sıcaklığı	Nominal Soğutma Kapasitesi (W)											
		-20		-15		-10		-5		0		5	
		Q	P	Q	P	Q	P	Q	P	Q	P	Q	P
WB15KE-PFJ	30	2788	1205	3369	1205	3981	1170	4983	1050	5986	1050	7005	1003
	40	2279	1612	2875	1612	3577	1506	4286	1500	4968	1500	5993	1450
	50	1730	2139	2285	2139	2793	2013	3410	1984	4205	1984	4867	1876
WB15KE-TFD	30	2788	1205	3369	1205	3981	1170	4983	1050	5986	1050	7005	1003
	40	2279	1612	2875	1612	3577	1506	4286	1500	4968	1500	5993	1450
	50	1730	2139	2285	2139	2793	2013	3410	1984	4205	1984	4867	1876
WB19KE-TFD	30	3386	1280	4013	1280	4998	1280	5983	1250	7083	1250	8359	1250
	40	2894	1640	3608	1640	4415	1640	5210	1610	6277	1610	7549	1610
	50	2337	2105	2994	2105	3576	2105	4486	2094	5106	2094	6326	2094
WB22KE-TFD	30	4226	1750	5109	1750	6043	1716	7462	1650	8934	1650	10016	1650
	40	3694	2391	4685	2391	5286	2354	6553	2290	7562	2290	9218	2290
	50	3075	2875	3795	2875	4397	2840	5419	2800	6395	2800	7546	2800
WB29KE-TFD	30	5539	2219	6884	2219	8377	2203	9938	2196	12004	2196	14063	2150
	40	4872	2795	5843	2795	7104	2781	8419	2758	9976	2758	12176	2700
	50	3995	3561	4877	3561	5983	3536	7095	3515	8387	3515	9987	3493
WB40KE-TFD	30	6995	2950	9136	2950	11076	3022	13270	3011	15822	3001	18732	2981
	40	6031	3681	7911	3681	9596	3808	11535	3797	13730	3777	16231	3746
	50	5049	4639	6584	4639	7962	4818	9596	4798	11433	4767	13577	4726
WB45KE-TFD	30	8289	3075	9854	3075	12467	3050	14861	3050	17298	3035	21007	3020
	40	7163	4095	8761	4095	10593	4075	12973	4075	15347	4050	18341	4035
	50	5986	5148	7136	5148	8974	5121	10579	5121	12941	5100	15049	5049
WB48KE-TFD	30	9106	3550	11016	3550	13551	3542	16410	3530	19579	3511	23183	3495
	40	7930	4429	9831	4429	11762	4416	14059	4410	16983	4395	20176	4318
	50	6334	5719	8005	5719	9795	5701	11846	5683	14007	5649	16958	5628
WB58KE-TFD	30	10531	4195	13007	4195	16004	4150	19573	4143	23492	4130	27943	4100
	40	9014	5246	11341	5246	14187	5219	17008	5208	19887	5185	24108	4150
	50	7113	6980	9268	6980	11543	6950	14138	6941	17064	6873	19871	6850
WB66KE-TFD	30	12432	4896	15386	4937	18632	4962	22296	5102	26684	5216	31654	5347
	40	10875	6112	13421	6270	16210	6351	19408	6410	23127	6492	27316	6588
	50	8968	7632	11198	7672	13501	7704	16229	7723	19228	7768	22836	7819
WB76KE-TFD	30	14391	5612	17684	5612	21831	5600	26009	5585	31374	5543	37009	5513
	40	12443	7005	15361	7005	18954	6984	22981	6950	27198	6912	32381	6894
	50	10050	8941	12943	8941	15576	8912	19108	8907	29837	8849	27104	8817
WB89KE-TFD	30	16831	6549	20743	6549	25140	6510	29716	6493	36153	6458	42950	6450
	40	14467	8143	17953	8143	21983	8106	26381	8067	31640	8043	37184	8027
	50	11593	9861	14876	9861	18347	9847	22149	9815	26419	9800	31392	9785
WB96KE-TFD	30	18007	7160	22046	7160	27009	7150	32315	7130	38761	7100	45931	7059
	40	15134	9138	19015	9138	23495	9118	28121	9101	33482	9086	39826	9047
	50			15107	11676	19043	11650	23419	11593	28007	11570	33108	11563
WB110KE-TFD	30	20958	8652	26492	8652	32461	8614	38971	8603	46451	8570	55009	8550
	40	17995	10983	22810	10983	27943	10950	33876	10917	40138	10850	47943	10800
	50			17682	13118	23004	13050	27915	13019	33076	13087	39760	13051

- 1 - Korunan en düşük evaporasyon sıcaklığı -20°C'dir.
- 2 - Test koşulları: Dönüş gazı sıcaklığı 18,3°C, Subcooling 0°C'dir.
- 3 - Q: Soğutma kapasitesi
P: Motor giriş gücü

WB15 - WB29

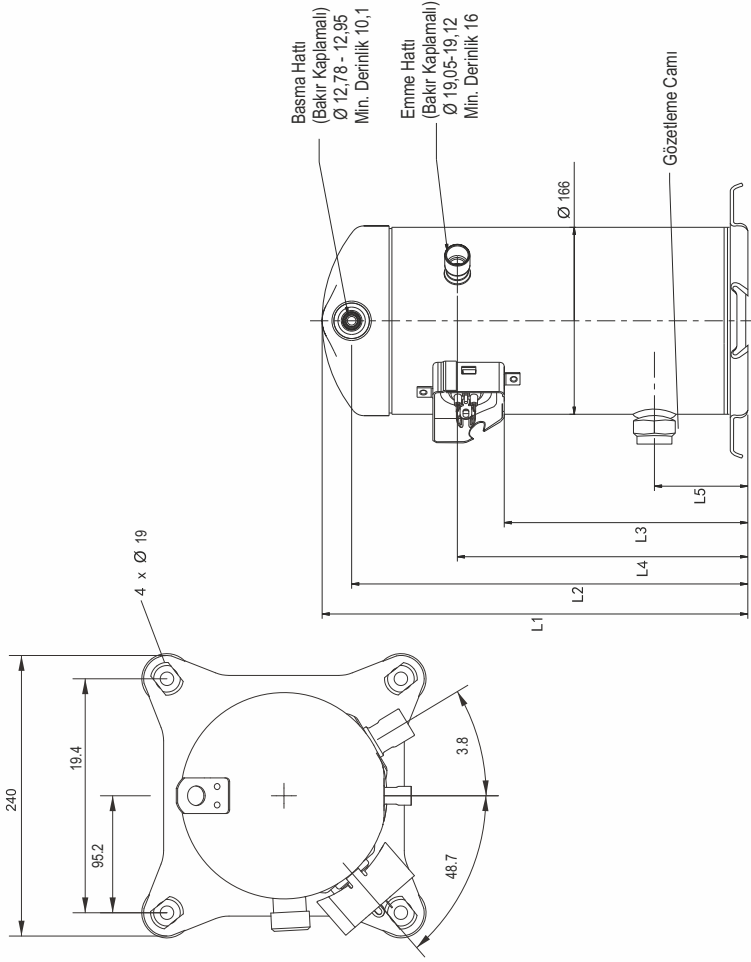

WB40 - WB48

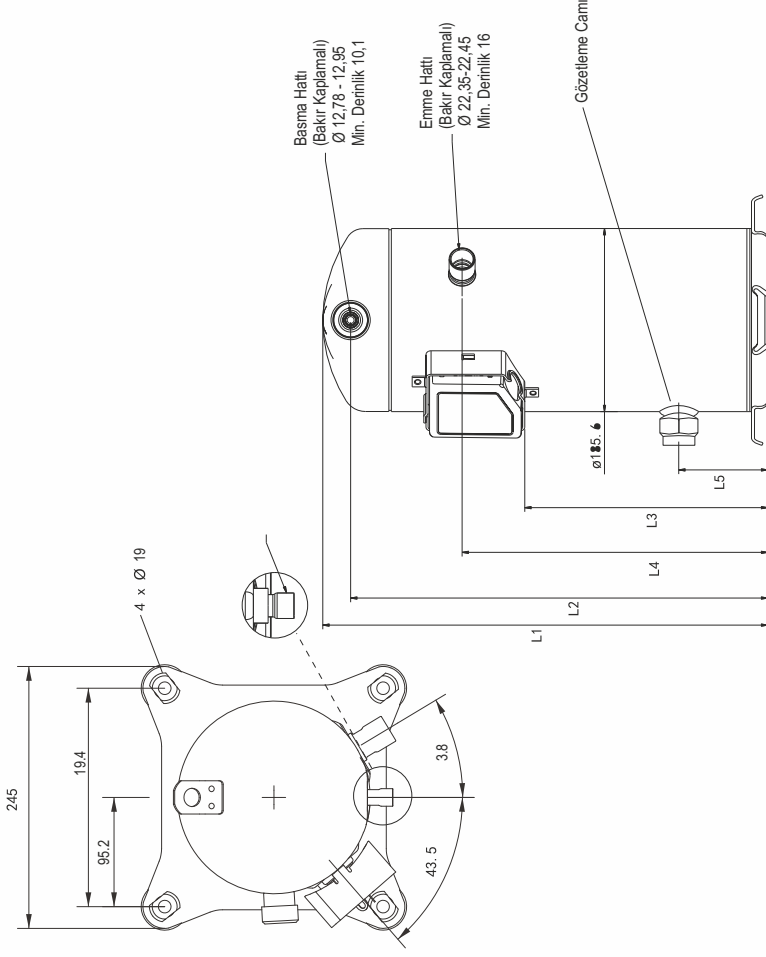

Ölçüler (mm)	WB15	WB19	WB22	WB29	WB40	WB45	WB48
L1	381,5	381,5	404,5	435,5	455,8	455,8	461,2
L2	356,2	356,2	378,9	407,8	427,6	427,6	431,5
L3	220,8	220,8	240,7	270,4	251,2	251,2	251,2
L4	262,3	262,3	282,2	312,2	314,5	314,5	314,5
L5	87,5	87,5	82,5	85,5	109,3	109,3	109,3

Bağlantı Kutusu Çizimi

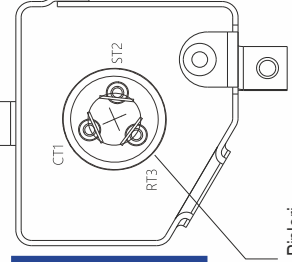

WB15 - WB29

Bağlantı Kutusu Çizimi

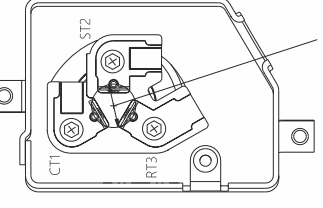

WB40 - WB48

Model		WR36KE-PFJ	WR42KE-PFJ	WR36KE-TFD	WR42KE-TFD	WR48KE-TFD	WR61KE-TFD	WR72 KE-TFD
Motor Voltajı		220~240V/50Hz/1ph			380~420V/50Hz/3ph			
Güç (hp)		3	3.5	3	3.5	4	5	6
Silindir Hacmi (m3/saat)		8.1	9.8	8.1	9.8	11.4	14.4	17.2
Soğutucu Gaz		R407C	R407C	R407C	R407C	R407C	R407C	R407C
Nominal Soğutma Kapasitesi (W)		8780	9610	8450	9920	11500	15100	16500
Giriş Gücü (W)		2636	3100	2630	3081	3550	4750	5600
COP (W/W)		3.33	3.31	3.21	3.22	3.24	3.18	2.95
Nominal Çalışma Akımı (A)		11,9	14	4.9	5.7	6.4	8.2	9.2
LRA (A)		83	102	33	44	57	61	75
Maksimum Çalışma Akımı (A)		18.3	22.4	7.5	8.6	9.7	11.7	13.9
Giriş Çıkış	Basma Hattı	1/2	1/2	1/2	1/2	1/2	1/2	1/2
	Ölçüleri	3/4	3/4	3/4	3/4	7/8	7/8	7/8
Ölçüler (mm)	En x Boy x Yükseklik	240x240x415	240x240x415	240x240x415	240x240x415	240x240x433	240x240x451	245x245x448
Montaj Ölçüsü (Çap) (mm)		190X190(Ø8.5)						
Yağ Tipi		POE						
Yağ İlk Şarj Miktarı (lt)		1.30	1.30	1.30	1.30	1.40	1.80	1.80
Tekrar Dolun Yağ Miktarı (lt)		1.30	1.30	1.30	1.30	1.40	1.80	1.80
Maksimum Çalışma Basıncı	Yüksek Basınç Tarafı	3.0	3.0	3.0	3.0	3.0	4.3	3.0
	Alçak Basınç Tarafı	2.0	2.0	2.0	2.0	2.0	2.0	2.0
Ağırlık (kg)		30,50	30	30.5	30	31.5	36.1	38.6
Karter Isıtıcısı Gücü (W)		70						

Not: Evaporasyon sıcaklığı 7,2 °C, Kondansasyon sıcaklığı 54,4 °C, Dönüş gazı sıcaklığı 18,0 °C'dir.

Kondansasyon "Subcooling" 8,3°C.

WR Serisi Orta ve Yüksek Sıcaklık

Model		WR81 KE-TFD	WR94 KE-TFD	WR108 KE-TFD	WR125 KE-TFD	WR144 KE-TFD	WR160 KE-TFD	WR110 KE-TFD
Motor Voltajı		380~420V/50Hz/3ph				420V/50Hz/3ph		
Güç (hp)		7	8	9	10	12	13	15
Silindir Hacmi (m3/saat)		18.8	22.1	25.5	29.1	33.2	36.3	43.3
Soğutucu Gaz		R407C	R407C	R407C	R407C	R407C	R407C	R407C
Nominal Soğutma Kapasitesi (W)		18900	22700	26100	30200	34700	37200	43700
Giriş Gücü (W)		6080	6880	7885	9020	10180	11480	13500
COP (W/W)		3.11	3.30	3.31	3.35	3.41	3.24	3.24
Nominal Çalışma Akımı (A)		10.8	12.8	14.1	15.8	17.6	20.5	26,3
LRA (A)		104	105	109	116	121	137	169
Maksimum Çalışma Akımı		16.3	17.5	20.2	22.5	25.3	27.8	31.4
Giriş Çıkış Ölçüleri	Basma Hattı	3/4	7/8	7/8	7/8	7/8	7/8	7/8
	Emme Hattı	7/8	1 1/8	1 3/8	1 3/8	1 3/8	1 3/8	1 3/8
Ölçüler (mm)	En x Boy x Yükseklik	245x245x453	242x242x488	242x242x549	242x242x549	242x242x549	242x242x561	242x242x561
Montaj Ölçüsü (Çap) (mm)		190X190(Ø8.5)						
Yağ Tipi		POE						
Yağ İlk Şarj Miktarı (lt)		1.80	2.70	3.0	3.0	3.0	3.2	3.2
Tekrar Dolum Yağ Miktarı (lt)		1.80	2.70	3.0	3.0	3.0	3.2	3.2
Maksimum Çalışma Basıncı	Yüksek Basınç Tarafı	3.0	3.0	3.0	3.0	3.0	3.0	3.0
	Alçak Basınç Tarafı	2.0	4.3	2.0	2.0	2.0	2.0	2.0
Ağırlık (kg)		39.0	57.2	60	61.2	61.2	64.9	66.2
Karter Isıtıcısı Gücü (W)		90						

Not: Evaporasyon sıcaklığı 7,2°C, Kondansasyon sıcaklığı 54,4°C, Dönüş gazı sıcaklığı 18,0 °C'dir.

Kondansasyon "Subcooling" 8,3°C.

R407C

WR Serisi Orta ve Yüksek Sıcaklık

Model	Kondansasyon Sıcaklığı	Nominal Soğutma Kapasitesi (W)											
		-10		-5		0		5		10		15	
		Q	P	Q	P	Q	P	Q	P	Q	P	Q	P
WR36KE-PFJ	45	4357	2216	5380	2241	6463	2269	7721	2337	9323	2439	11380	2504
	50	4175	2454	5109	2468	6254	2516	7380	2560	8921	2646	10722	2663
	55	4002	2699	4808	2702	5979	2750	7051	2782	8533	2820	10283	2891
WR42KE-PFJ	45	4872	2686	6076	2731	7412	2790	8889	2839	10695	2932	12662	2991
	50	4646	2963	5642	3004	6791	3069	8103	3126	9722	3237	10569	3315
	55	4386	3286	5357	3329	6517	3410	7693	3473	9087	3581	10783	3654
WR48KE-PFJ	45	5723	3095	7138	3128	8707	3170	10443	3214	12564	3326	14874	3393
	50	5458	3364	6628	3367	7978	3427	9519	3532	11421	3641	13591	3729
	55	5152	3709	6294	3730	7656	3782	9037	3802	10675	3883	12667	3962
WR36KE-TFD	45	4245	2170	5242	2192	6297	2213	7524	2284	9084	2387	10829	2453
	50	4068	2396	4978	2410	6093	2463	7191	2504	8538	2593	10403	2598
	55	3900	2637	4685	2638	5825	2687	6870	2719	8230	2755	10049	2814
WR42KE-TFD	45	4882	2625	6087	2667	7256	2723	8702	2775	10452	2861	12443	2924
	50	4609	2893	5596	2940	6736	3001	8038	3058	9644	3153	11534	3247
	55	4351	3211	5314	3263	6465	3331	7631	3395	9074	3500	10719	3572
WR48KE-TFD	45	5744	3025	7162	3055	8536	3095	10238	3142	12297	3246	14640	3317
	50	5422	3284	6584	3294	7925	3352	9457	3455	11347	3547	13570	3652
	55	5119	3625	6253	3655	7606	3695	8978	3716	10676	3795	12611	3873
WR61KE-TFD	45	8188	3565	9958	3615	12164	3650	14373	3800	17238	3950	20512	4029
	50	7643	3950	9393	3954	11411	4051	13255	4153	16147	4295	19128	4442
	55	7203	4350	8702	4359	10755	4421	12682	4495	15338	4595	18266	4685
WR72KE-TFD	45	8844	4180	10833	4235	13344	4295	16026	4500	19170	4698	23368	4835
	50	8432	4628	10216	4628	12608	4750	15371	4820	18299	5040	22290	5150
	55	7930	5121	9684	5129	11950	5206	14220	5284	17052	5400	20380	5535
WR81KE-TFD	45	9605	4759	11828	4799	14602	4809	17255	4876	20518	4931	24256	5052
	50	9193	5301	11169	5342	13851	5395	16610	5413	19792	5465	23425	5583
	55	8678	5900	10597	5980	13229	5995	15626	6105	18613	6227	22264	6340
WR94KE-TFD	45	11882	5700	14633	5735	17870	5814	21622	5840	25518	6054	31100	6230
	50	11233	6359	13790	6441	17122	6474	20900	6541	24587	6617	29923	6768
	55	10631	7143	13186	7201	16168	7219	19265	7295	22733	7372	27560	7525
WR108KE-TFD	45	14335	6345	10883	6386	22051	6524	26862	6723	31741	6881	38683	7084
	50	13790	6971	16985	7017	20749	7167	25535	7386	30691	7556	37503	7709
	55	12972	7746	15871	7797	19780	7964	23581	8208	28745	8401	35327	8577
WR125KE-TFD	45	16439	7204	20738	7289	25289	7318	30806	7359	36400	7606	44362	7830
	50	15815	8007	19478	8119	23795	8173	29283	8267	35197	8339	43009	8502
	55	14876	8959	18201	9075	22684	9108	27042	9159	32965	9243	40514	9437
WR144KE-TFD	45	17553	8217	21131	8249	25170	8357	29604	8429	35204	8679	41993	8906
	50	16146	9176	19701	9273	23070	9318	27664	9456	33463	9541	40170	9823
	55	15131	10289	18605	10378	21642	10400	26337	10479	31239	10571	37118	10803
WR160KE-TFD	45	18321	9453	22418	9495	27556	9618	33319	9674	40621	9981	48873	10301
	50	17728	10551	21632	10668	26347	10701	32148	10887	37665	10983	45467	11270
	55	16753	11804	20647	11902	24832	11958	30060	12029	36130	12128	43736	12328
WR190KE-TFD	45	22818	11285	27917	11334	34043	11486	41520	11549	49435	11934	59134	12282
	50	21991	12556	26836	12728	33022	12775	38689	12801	45853	13085	54132	13545
	55	20709	14095	25189	14209	31212	14259	36880	14385	43788	14472	51634	14799

1 - Superheat ; 11,1 K ve Subcooling 8,3 K'dir.

2 - Q: Soğutma kapasitesi

P: Motor giriş gücü

WR36 - WR48

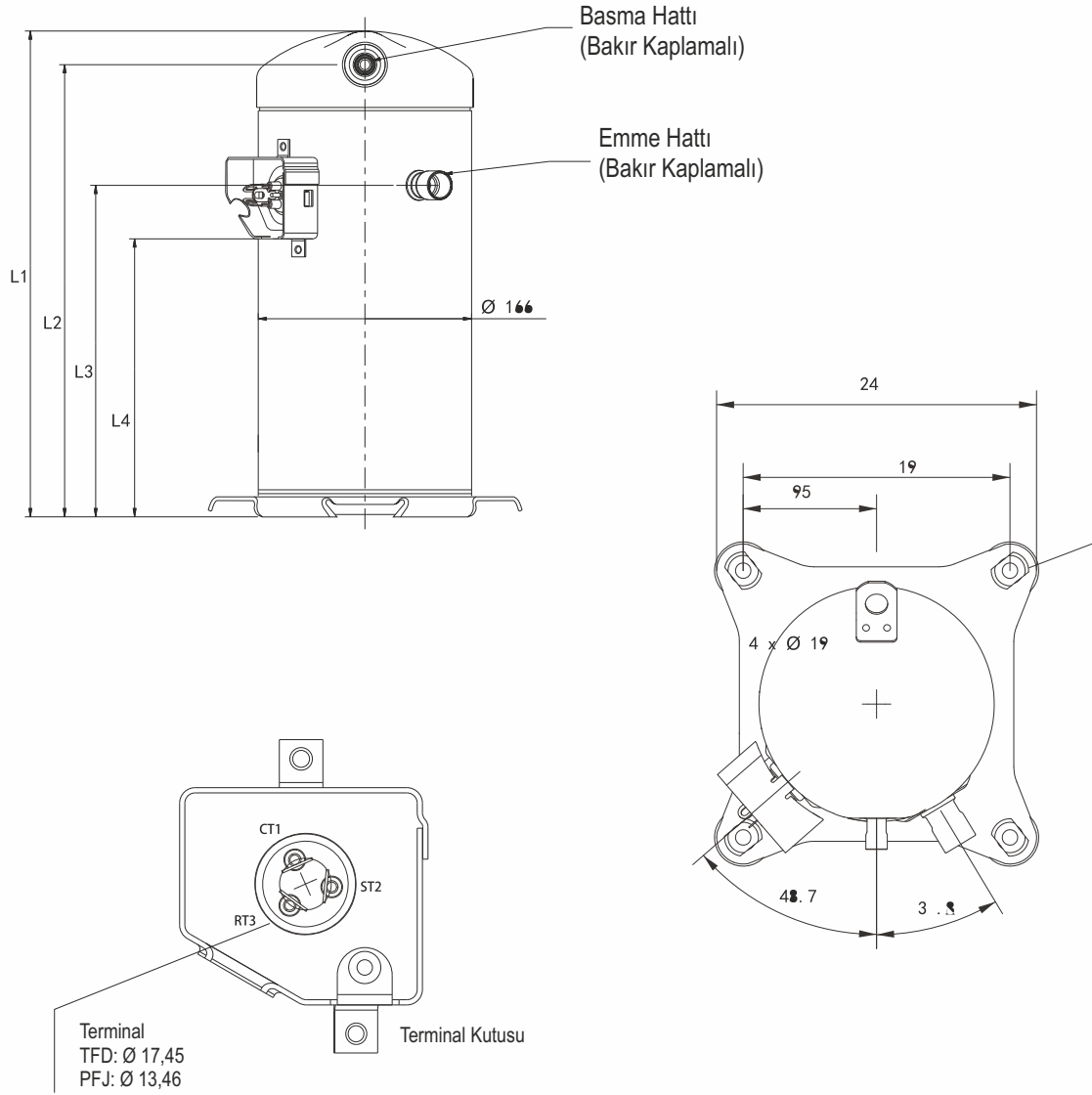

	WR36	WR42	WR48
Basma Hattı (mm)	12.78-12.95	12.78-12.95	12.78-12.95
Emme Hattı (mm)	19.13-19.30	19.13-19.30	22.35-22.45
Çap (mm)	166	166	166
L1	415	415	433
L2	391	391	408
L3	292	292	309
L4	250	250	270

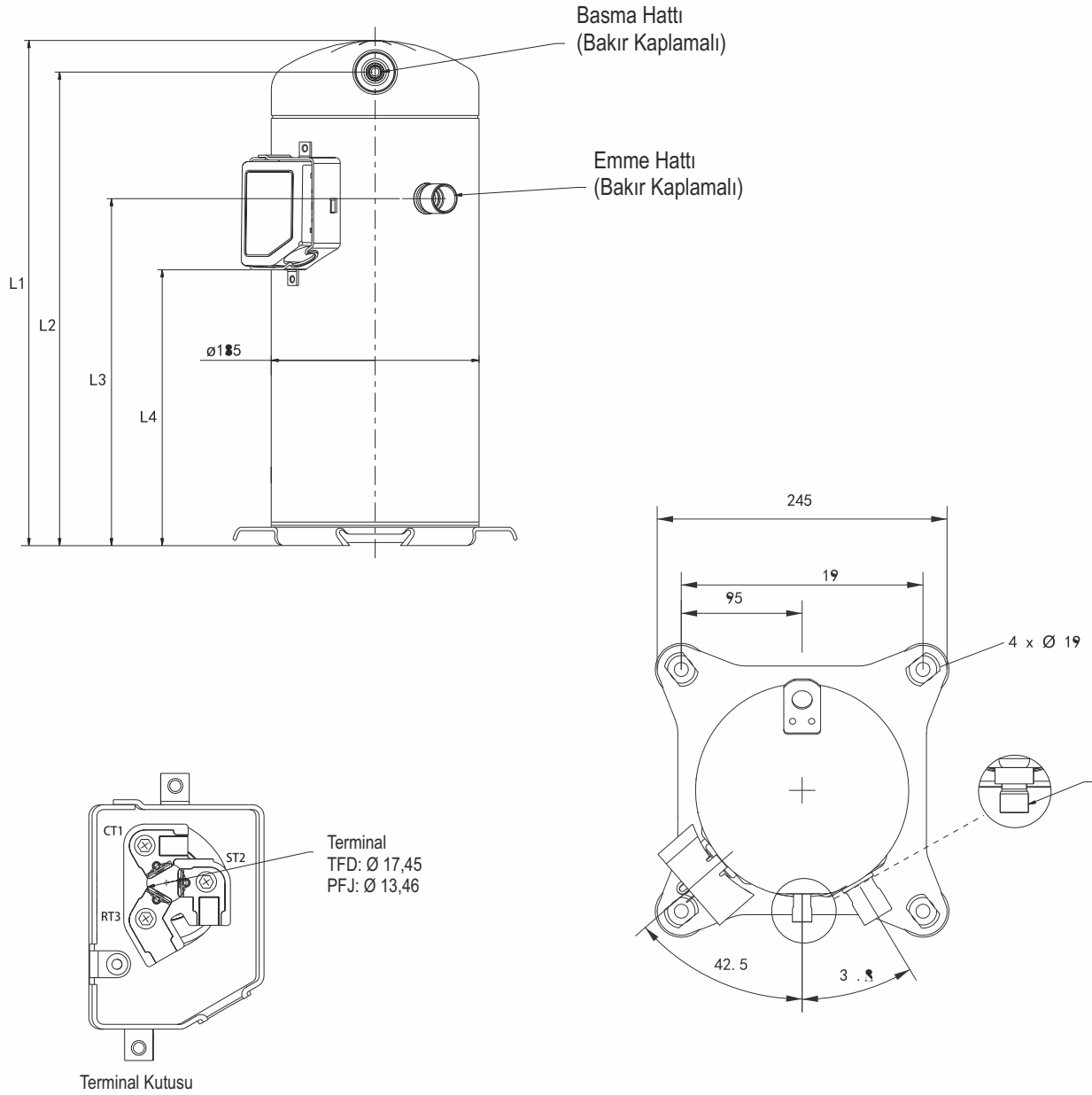

	WR61	WR72	WR81
Basma Hattı (mm)	12.78-12.95	12.78-12.95	19.13-19.30
Emme Hattı (mm)	22.35-22.45	22.35-22.45	22.35-22.45
Çap (mm)	185	185	185
L1	451	448	453
L2	423	423	428
L3	309	309	309
L4	250	250	250

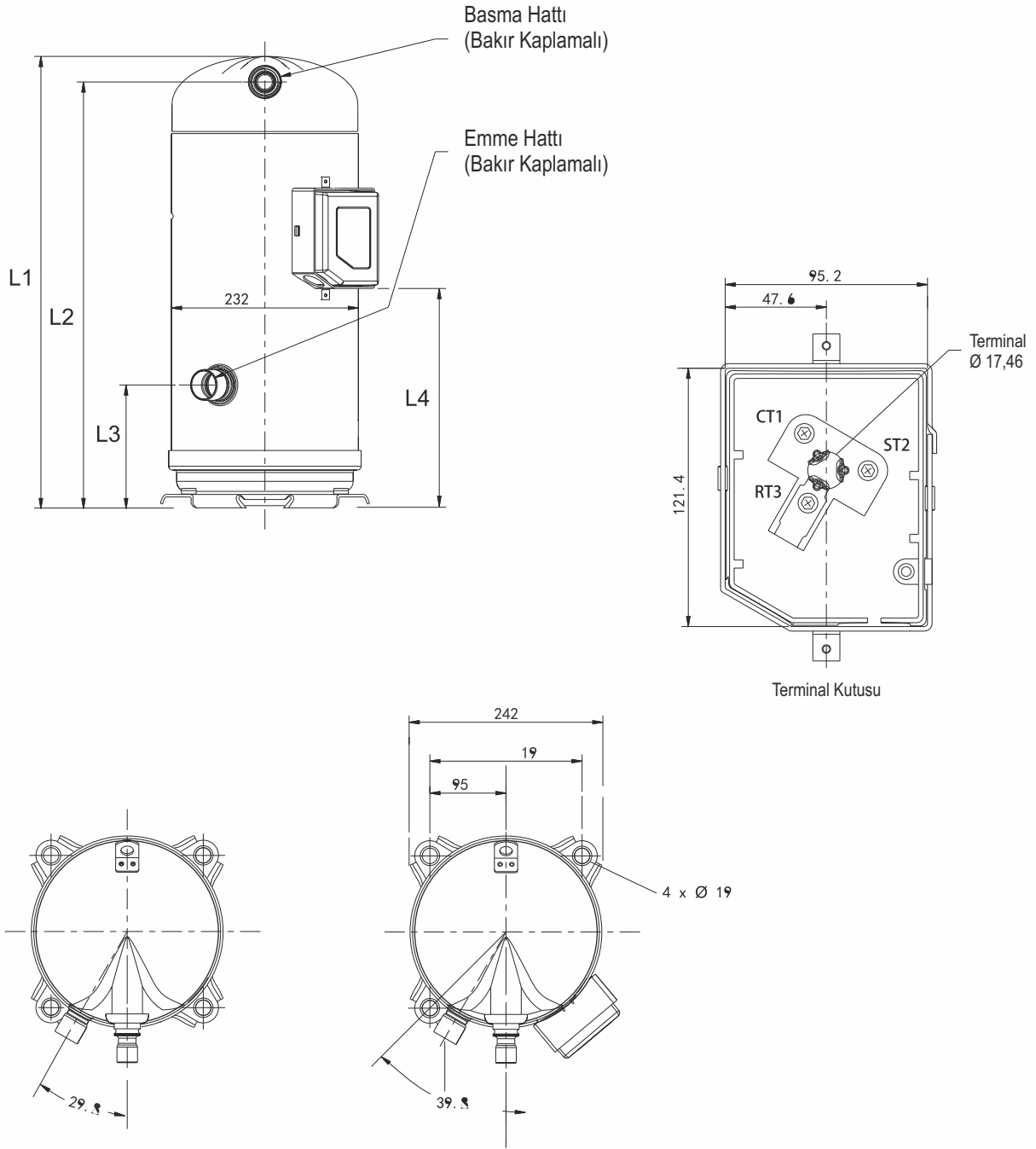

	WR94	WR108	WR125	WR144	WR160	WR190
Basma Hattı (mm)	22.35-22.45	22.35-22.45	22.35-22.45	22.35-22.45	22.35-22.45	22.35-22.45
Emme Hattı (mm)	28.49-28.67	34.99-35.15	34.99-35.15	34.99-35.15	34.99-35.15	34.99-35.15
Çap (mm)	232	232	232	232	232	232
L1	488	549	549	549	561	561
L2	455	513	513	513	533	533
L3	105	135	135	135	154	154
L4	215	250	250	250	271	271



Mahmut Őevket PaŐa Mah. Őahinkaya Sokak
No: 25/5 34384 BeyoĐlu - ŐiŐli / İSTANBUL
Tel: +90 (212) 231 05 01 (pbx) Fax: +90 (212) 248 01 81
Whatsapp: +90 530 414 97 22
info@atilimicdis.com - www.atilimicdis.com