

# Vcolor 618

Controller for retarding-proofing cabinets and rooms, with 5 or 7-inch colour TFT touch-screen graphic display, in split version





**Important**

Read this document carefully before installation and before using the device and take all the prescribed precautions. Keep this document with the device for future consultation.

Only use the device in the ways described in this document. Do not use the device as safety device.



**Disposal**

The device must be disposed of according to local regulations governing the collection of electrical and electronic waste.

## Index

1	INTRODUCTION.....	4	8.4	Pre-cooling.....	27
1.1	Introduction.....	4	9	REGULATIONS.....	29
1.2	Table listing the models available, their main features and purchasing codes.....	5	9.1	Pre-cooling.....	29
2	MEASUREMENTS AND INSTALLATION.....	7	9.2	Temperature regulation.....	29
2.1	Vcolor 618 M user interface measurements.....	7	9.3	Humidity regulation.....	30
2.2	Vcolor 618 L user interface measurements.....	7	10	LOAD MANAGEMENT.....	32
2.3	User interface installation.....	8	10.1	Compressor management.....	32
2.4	Control module measurements.....	9	10.2	Pump-down management.....	32
2.5	Control module installation.....	9	10.3	Evaporator fan management.....	32
2.6	Installation precautions.....	9	10.4	Defrost management.....	33
3	ELECTRICAL CONNECTION.....	10	10.5	Heater management.....	33
3.1	Vcolor 618 M electrical connection.....	10	10.6	Steam generator output management.....	33
3.2	Vcolor 618 L electrical connection.....	12	10.7	Humidifier output management.....	33
3.3	Precautions for electrical connection.....	13	10.8	Dehumidification management.....	34
4	DESCRIPTION.....	14	10.9	Condenser fan management.....	34
4.1	User interface description.....	14	10.10	Cabinet light management.....	34
4.2	Control module description.....	15	11	MANAGING THE USB PORT.....	35
5	FIRST-TIME USE.....	16	12	ALARMS.....	36
5.1	Operating modes.....	16	13	EPOCA CLOUD PLATFORM.....	39
5.2	Operating the device.....	16	14	PARAMETERS.....	40
6	NAVIGATION.....	18	15	ACCESSORIES.....	48
6.1	Initial information.....	18	15.1	Safety transformer (ECTSFD004).....	48
6.2	Home screen.....	18	15.2	Non-optoisolated RS-485/USB serial interface (EVIF20SUXI).....	48
6.3	Run screen.....	19	15.3	USB plug for panel installation (0812000002).....	48
6.4	Screen Saver.....	20	15.4	Connecting cables (0810500018/0810500020).....	48
6.5	Settings screen.....	20	15.5	Phase cutting speed regulator (EVDFAN1).....	48
7	AN OVERVIEW OF THE FUNCTIONS.....	22	15.6	USB flash drive (EVUSB4096M).....	49
7.1	Automatic and manual cycles.....	22	15.7	Graphic synoptic device (EVC25T00X7XXX04).....	49
7.2	Other functions.....	23	15.8	Polyester overlay (0041600281).....	49
8	MAIN FUNCTIONS.....	24	15.9	EVlink Wi-Fi RS-485 module (EVIF25SWX).....	49
8.1	Manual cycle.....	24	16	TECHNICAL SPECIFICATIONS.....	50
8.2	Automatic cycle.....	25	16.1	Technical specifications.....	50
8.3	Recipe book.....	27			

## **1 INTRODUCTION**

### **1.1 Introduction**

Vcolor 618 is a controller with elegant design for the management of retarding-proofing cabinets and rooms.

It is available in a split version and the user interface has a 5-inch or 7-inch capacitive TFT touch-screen graphic display in glass, 65 k colours, 800 x 480 pixel resolution and IP65 protection degree. The user interface can be installed recessed from the front or flush with the panel thus making it fit perfectly with the design of the unit.

It is able to manage automatic retarding-proofing cycles (stopping, storing, awakening, proofing and slowing phases) and manual storing and proofing cycles (with independent temperature, humidity and ventilation intensity management for each phase). It also has the "programs" function and a communication port for common USB flash drives.

Upon request, the controllers can be equipped with Wi-Fi connectivity so it can interact remotely with the unit through the EPoCA® cloud platform, with the option of starting/stopping working cycles.

## 1.2 Table listing the models available, their main features and purchasing codes

The table below lists the models available.

<b>Models available</b>	<b>Vcolor 618 M</b>	<b>Vcolor 618 L</b>
	5-inch capacitive TFT touch-screen graphic display in glass	7-inch capacitive TFT touch-screen graphic display in glass

The table below shows the main features of the device.

<b>Power supply</b>	<b>Vcolor 618 M</b>	<b>Vcolor 618 L</b>
Control module	115...230 VAC	115...230 VAC
User interface	powered by the control module	12 VAC
<b>Analogue inputs</b>	<b>Vcolor 618 M</b>	<b>Vcolor 618 L</b>
Cabinet probe (PTC/NTC)	•	•
Evaporator probe (PTC/NTC)	•	•
Condenser probe (PTC/NTC)	•	•
Humidity probe (4-20 mA)	•	•
<b>Digital inputs (for normally open/normally closed contact)</b>	<b>Vcolor 618 M</b>	<b>Vcolor 618 L</b>
Door switch	•	•
Compressor thermal switch	•	•
Low pressure switch	•	•
High pressure switch	•	•
<b>Analogue outputs</b>	<b>Vcolor 618 M</b>	<b>Vcolor 618 L</b>
PWM (evaporator fan)	•	•
<b>Digital outputs (electro-mechanical relays; A res. @ 250 VAC)</b>	<b>Vcolor 618 M</b>	<b>Vcolor 618 L</b>
Compressor	16 A	16 A
Defrost	8 A	8 A
Humidifier	8 A	8 A
Heaters	16 A	16 A
Steam generation	8 A	8 A
Cabinet light	8 A	8 A
Load 4 (configurable, dehumidifier default)	8 A	8 A
Load 8 (configurable, pump down valve default)	8 A	8 A
<b>Communications ports</b>	<b>Vcolor 618 M</b>	<b>Vcolor 618 L</b>
RS-485 MODBUS	•	•
USB	•	•
<b>Other features</b>	<b>Vcolor 618 M</b>	<b>Vcolor 618 L</b>
Clock	•	•
Alarm buzzer	•	•
Management of automatic retarding-proofing cycles	•	•

and manual conservation and proofing cycles		
Fan intensity management	•	•
HACCP function	•	•
"Programs" function	•	•
Wi-Fi connectivity for remote management through the EPoCA portal (with module EVlink Wi-Fi EVIF25SWX)	•	•

For more information see the section 16 "TECHNICAL SPECIFICATIONS".

The table below shows the purchasing codes.

<b>Purchasing codes</b>	<b>Vcolor 618 M (control module + 5-inch user interface kit):</b>
	<b>EVCMC618N9E</b> (flush installation)
	<b>EVCMC618N9EF</b> (semi-recessed installation)
	<b>Vcolor 618 L (control module + 7-inch user interface kit):</b>
	<b>EVCLC618N9E</b> (flush installation)
	<b>EVCLC618N9EF</b> (semi-recessed installation)
	<b>EVlink Wi-Fi module:</b>
	<b>EVIF25SWX</b>

For more models contact the EVCO sales network.

## 2 MEASUREMENTS AND INSTALLATION

### 2.1 Vcolor 618 M user interface measurements

The pictures below show the measurements of the 5-inch user interface; measurements are expressed in mm (inches).

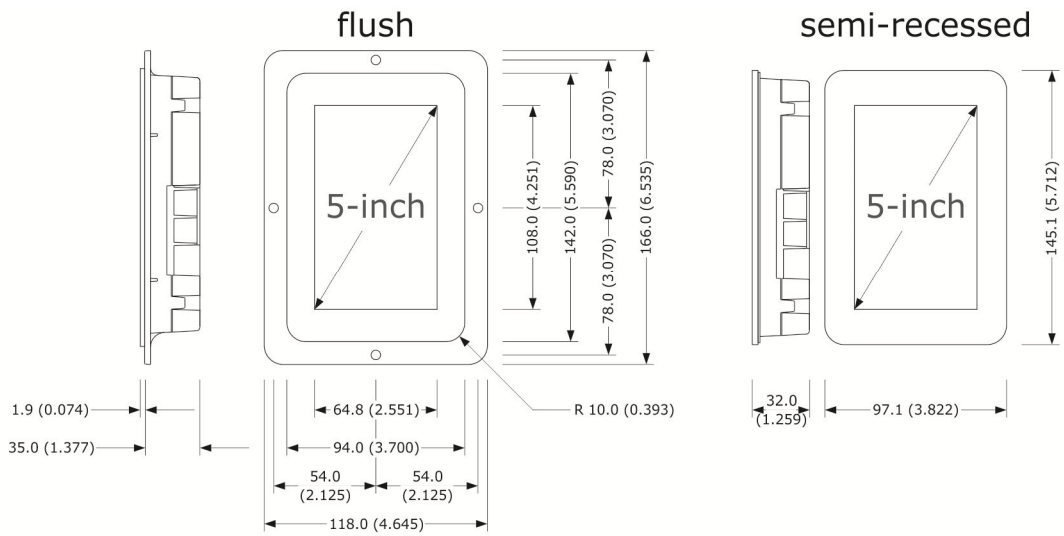

### 2.2 Vcolor 618 L user interface measurements

The pictures below show the measurements of the 7-inch user interface; measurements are expressed in mm (inches).

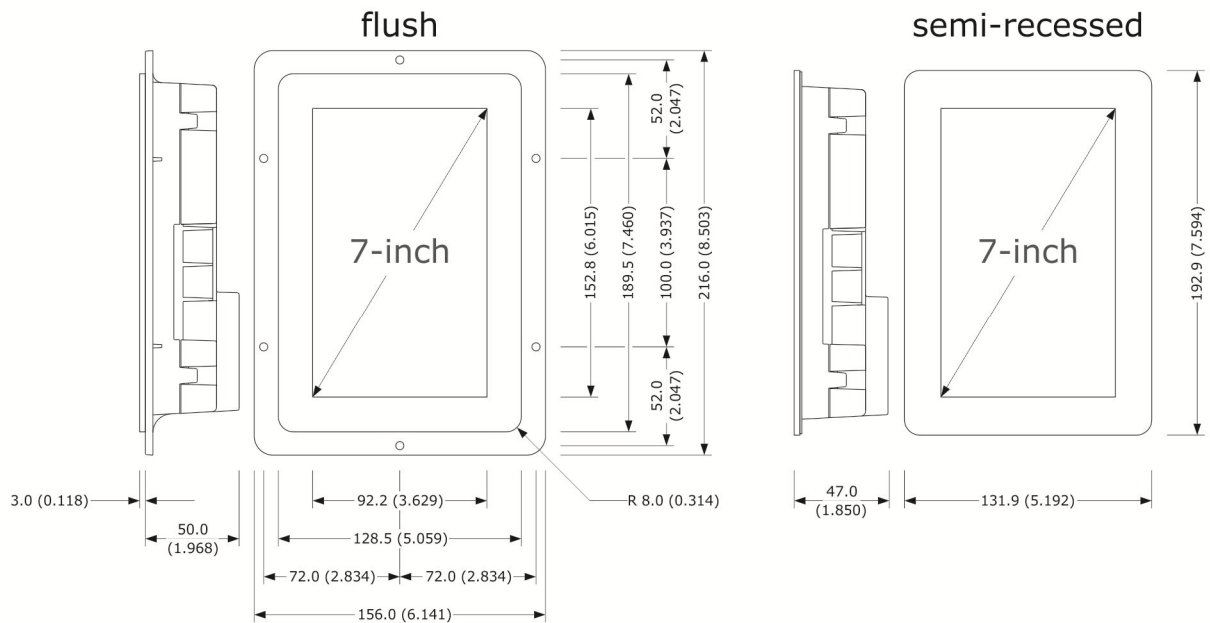

### 2.3 User interface installation

The picture below shows the installation of the user interface.

Depending on the model, installation can be:

- flush, from behind the panel with threaded studs (not provided) welded to hold it in place;
- semi-recessed, from the front of the panel with spring clips to hold it in place.
- 

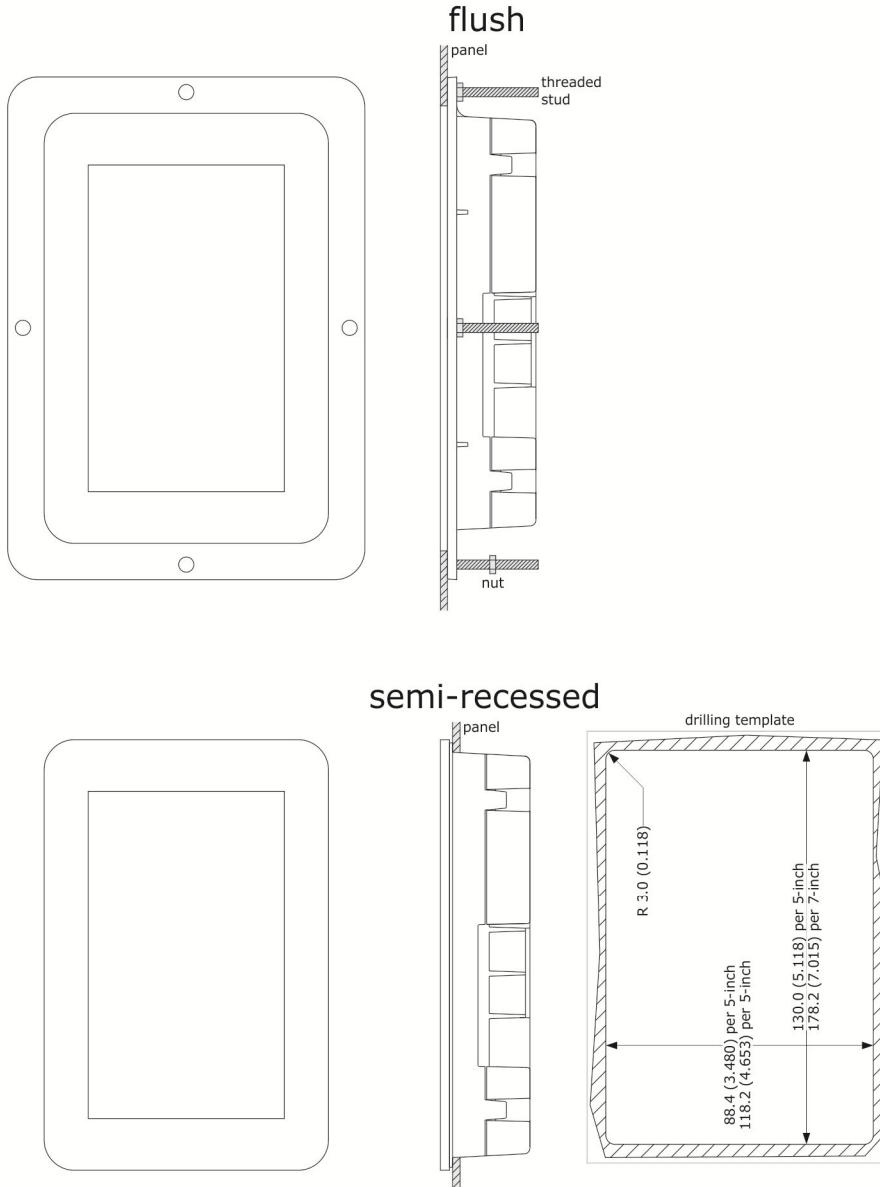



## 2.4 Control module measurements

The pictures below show the measurements of the control module; measurements are expressed in mm (inches).

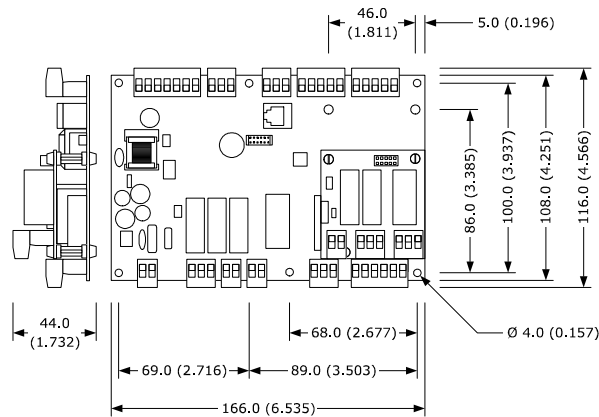

## 2.5 Control module installation

Installation of the control module is on a flat surface with spacers.

## 2.6 Installation precautions

- Ensure that the working conditions for the device (operating temperatures, humidity, etc.) are within the set limits. See section 16 TECHNICAL SPECIFICATIONS.
- Do not install the device close to heat sources (heaters, hot air ducts, etc.), equipment with a strong magnetic field (large diffusers, etc.), in places subject to direct sunlight, rain, damp, excessive dust, mechanical vibrations or shocks.
- Any metal parts close to the control module must be far enough away so as not to compromise the safety distance.
- In compliance with safety regulations, the device must be installed properly to ensure adequate protection from contact with electrical parts. All protective parts must be fixed in such a way as to need the aid of a tool to remove them.

### 3 ELECTRICAL CONNECTION

#### 3.1 Vcolor 618 M electrical connection

The picture below shows the Vcolor 618 M electrical connection.

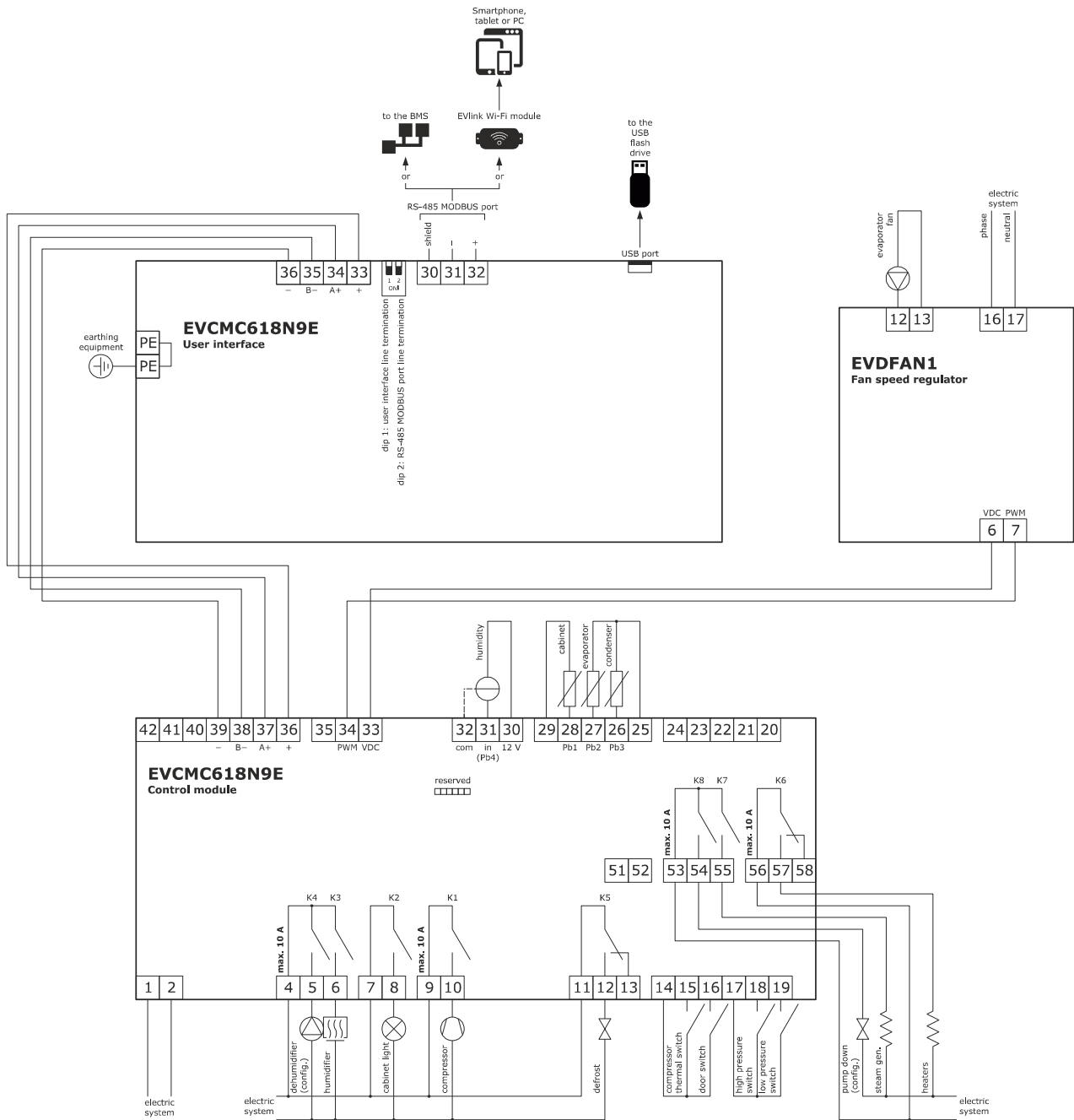

Details of EVlink Wi-Fi electrical connection

**Vcolor 618M**  
User interface

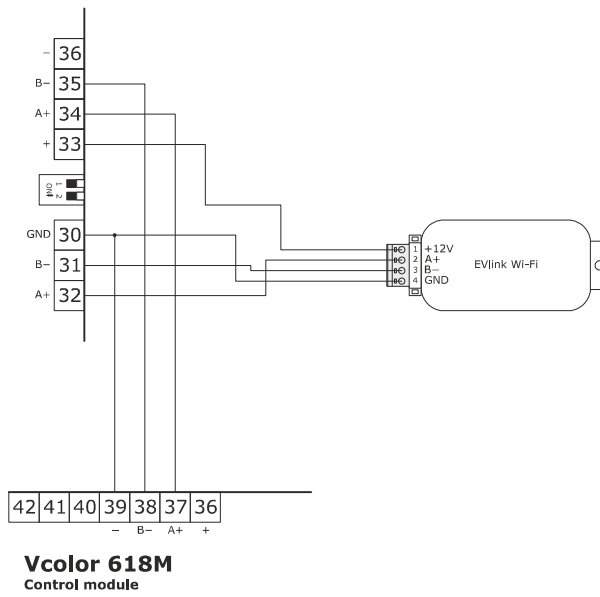

### 3.2 Vcolor 618 L electrical connection

The picture below shows the Vcolor 618 L electrical connection.

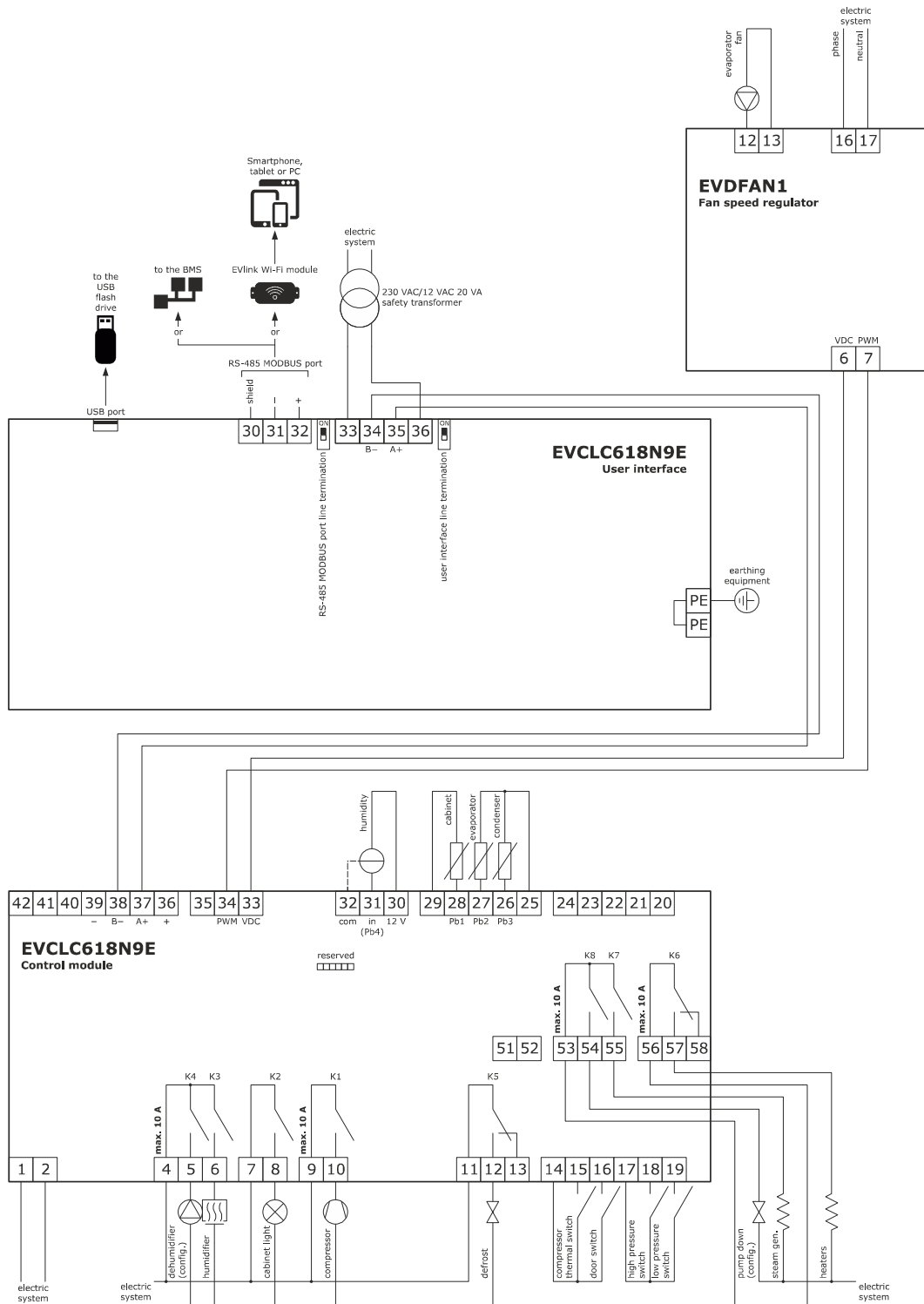

Details of EVlink Wi-Fi electrical connection

**Vcolor 618L**  
User interface

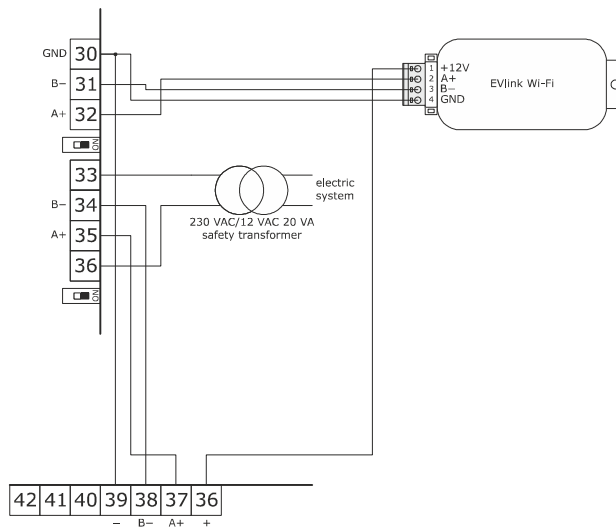

**Vcolor 618L**  
Control module

### 3.3 Precautions for electrical connection

- Do not use electric or pneumatic screwdrivers on the terminal blocks of the device.
- If the device has been moved from a cold to a warm place, the humidity may cause condensation to form inside. Wait about an hour before switching on the power.
- Make sure that the supply voltage, electrical frequency and power of the device correspond to the local power supply. See section 16 TECHNICAL SPECIFICATIONS.
- Disconnect the device from the power supply before doing any type of maintenance.
- Connect the power cables as far away as possible from those for the signal.
- To reduce reflections on the signal transmitted along the cables connecting the user interface to the control module it is necessary to fit a termination resistor.
- For repairs and for further information on the device, contact the EVCO sales network.

## 4 DESCRIPTION

### 4.1 User interface description

The picture below shows the front view of the Vcolor 618 L user interface.

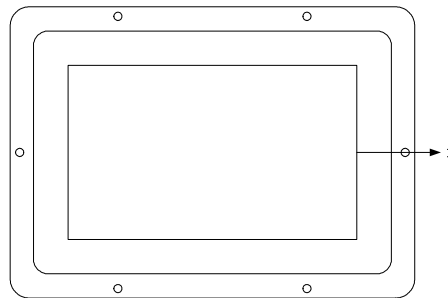

The table below describes the front parts of the user interface.

PART	DESCRIPTION
1	display

The picture below shows the back view of the Vcolor 618 L user interface.

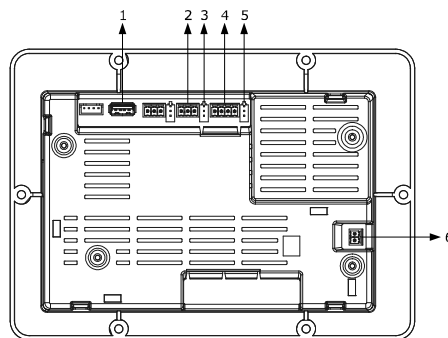

The table below describes the back parts of the user interface.

PART	DESCRIPTION
1	USB communications port
2	RS-485 MODBUS communications port
3	dip switch for the termination resistor for the RS-485 MODBUS port
4	user interface-control module connection
5	dip switch for the termination resistor of the user interface
6	appliance earthing

For more information see subsequent sections.

## 4.2 Control module description

The diagram below shows the intended use of the control module connectors.

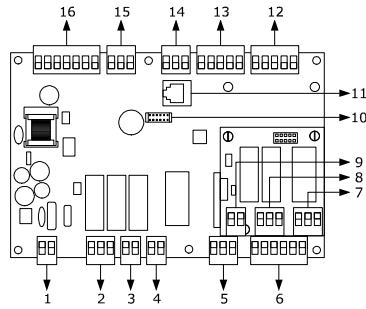

PART	DESCRIPTION
1	control module power supply
2	K4 and K3 relays
3	K2 relay
4	K1 relay
5	K5 relay
6	digital inputs
7	K6 relay
8	K7 and K8 relays
9	unused
10	unused
11	unused
12	unused
13	PTC/NTC analogue inputs
14	analogue input 4-20 mA
15	analogue output
16	user interface-control module connection

For more information see subsequent sections.

## 5 FIRST-TIME USE

### 5.1 Operating modes

The controller has the following operating modes:

- "off" (no power to the device);
- "stand-by" (the device is powered but switched off);
- "on" (the device is powered, switched on and awaiting start-up of an operating cycle);
- "run" (the device is powered, switched on and running an operating cycle).

Terminology: "switch on the device" means moving from "stand-by" to "on" mode and "switch off the device" means moving from "on" to "stand-by" mode.

If there is a power failure, when power is restored the device will return to the mode set before the failure.

### 5.2 Operating the device

Follow these instructions to operate the device.

1. Install the device as shown in section 2 MEASUREMENTS AND INSTALLATION taking all the precautions mentioned in paragraph 2.6 Installation precautions.
2. Make the electrical connection as shown in section 3 ELECTRICAL CONNECTION.
3. Connect the power supply to the device: if parameter E9 is set at 1 (default), the device will show the EVCO splash screen for 10 seconds; if the parameter is set at 0, a system loading screen will be shown:

E9=1



E9=0

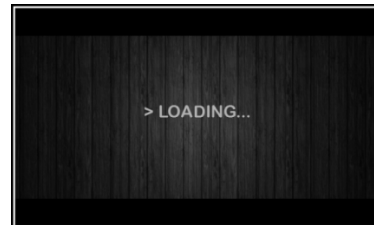

Once loading is complete, the device will display the mode it was in before being powered down:



- On/Stand-by screen, press the central area to move to the Home screen;
- directly the Home screen.

On/stand-by screen



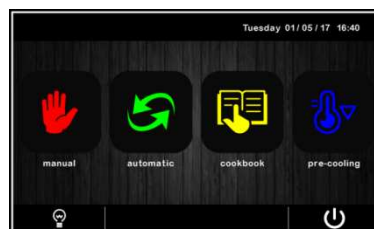

Home screen



To switch the device on, on the On/stand-by screen press the central key ; to switch the device off, on the Home screen press the  key on the lower part of the screen.

**N.B.** If the power supply has been cut off long enough to cause a clock error (RTC alarm), it will be necessary to reset the date and time.

4. When switching on from the settings key  on the On/stand-by screen, enter the SET DATE/TIME menu and touch the data to change by confirming it with **OK**.
5. By touching the settings key  on the On/stand-by screen, enter the SERVICE menu and from here the PARAMETERS menu. Enter the password -19 and configure the device as you wish in the order in which the parameters are listed in the table below. Then check that the remaining parameters have been set in a consistent way. See later sections and in particular section 14 PARAMETERS.





Par.	Min.	Max.	Unit	Default	
P0	0	1	----	1	Type of probe 0 = PTC 1 = NTC
P3	0	1	----	1	Enable evaporator probe 0 = Disabled 1 = Enabled
P4	0	1	----	0	Enable condenser probe 0 = Disabled 1 = Enabled
rU0	0	1	----	0	Humidity management mode: 0 = with humidity probe 1 = without the humidity probe, time intervals based on the percentage set
i1	0	1	----	1	Door switch input contact type 0 = normally open (input active with contact closed) 1 = normally closed (input active with contact open)
i4	0	1	----	0	High pressure input contact type 0 = normally open (input active with contact closed) 1 = normally closed (input active with contact open)
i6	0	3	----	2	Effect caused by activation of the low pressure input 0 = no effect 1 = <u>ALARM</u> The compressor and evaporator fan are switched off 2 = <u>PUMP-DOWN AND ALARM MANAGEMENT</u> While the compressor is being switched off the digital input will act to switch off the compressor output to end the pump-down phase. During the activation phases of the refrigeration plant the digital input will act to switch off the compressor and evaporator fan. 3 = <u>COMPRESSOR THERMAL SWITCH ALARM</u> Compressor is switched off
i7	0	1	----	0	Low pressure input contact type 0 = normally open (input active with contact closed) 1 = normally closed (input active with contact open)
i10	0	1	----	1	Thermal switch input contact type 0 = normally open (input active with contact closed) 1 = normally closed (input active with contact open)
u1	0	2	----	0	Load managed by output K8 0 = Pump down valve (with this setting parameter u2 is relevant) 1 = evaporator fan (in which case the output will repeat in ON/OFF mode the status of the PWM output for the evaporator fan) 2 = dehumidifier/extractor fan (with this setting parameters rU5 and rU6 are relevant)
u3	0	1	----	0	Load managed by output K4 0 = dehumidifier/extractor fan (with this setting parameters rU5 and rU6 are relevant) 1 = Condenser fan (with this setting parameters F16 and F17 are relevant)  With u3 = 1 dehumidification will be managed automatically by activation of the refrigeration plant
E12	0	2	----	0	Type of humidifier 0 = humidifier with steamer 1 = humidifier with serial control (EASYSTEAM)

| | | | 2 = humidifier with instant generation

## 6 NAVIGATION

### 6.1 Initial information

Navigating the menus is intuitive, based on touch technology.

- To enter into a procedure touch the menu or the corresponding icon
- To exit the procedure and, in general, to return to the previous level, press the Back  key
- To scroll up and down a menu use the  and  keys
- To confirm the settings and/or changes press the **OK** key
- To start up a cycle press **START**
- To interrupt a cycle hold down **STOP** for at least 4 seconds
- To regulate a setting, use the - and + keys or press and drag the relevant bar
- To silence the buzzer touch any key while it is sounding. If the buzzer is sounding for the end of an automatic cycle or because the pre-cooling temperature has been reached, the buzzer will be deactivated automatically after the number of seconds set by parameter E12 (unless it is silenced manually).

### 6.2 Home screen

The Home screen is the departure point for navigating the user interface.

The Home screen displays the functions enabled, the date and the time.

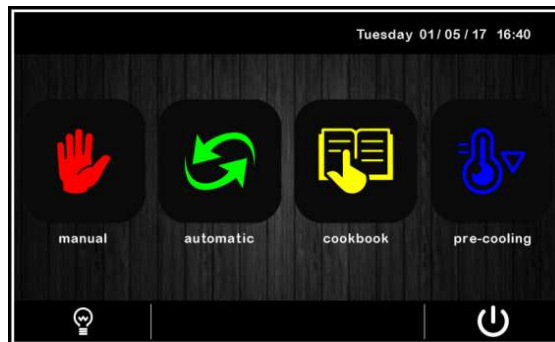

All the end-user's selections start from the Home screen.

The 4 interactive keys grant access to the following functions



MANUAL

select, set and start up a manual cooling or heating cycle

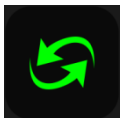

AUTOMATIC

select, set and start up a complete automatic retarding-proofing cycle



RECIPE BOOK

Select and/or change automatic retarding-proofing cycles saved in the memory

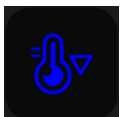

PRE-COOLING

set and start up a cabinet pre-cooling cycle

### 6.3 Run screen

Once a manual or automatic cycle has been started up, the Run screen will appear for the type of cycle selected.

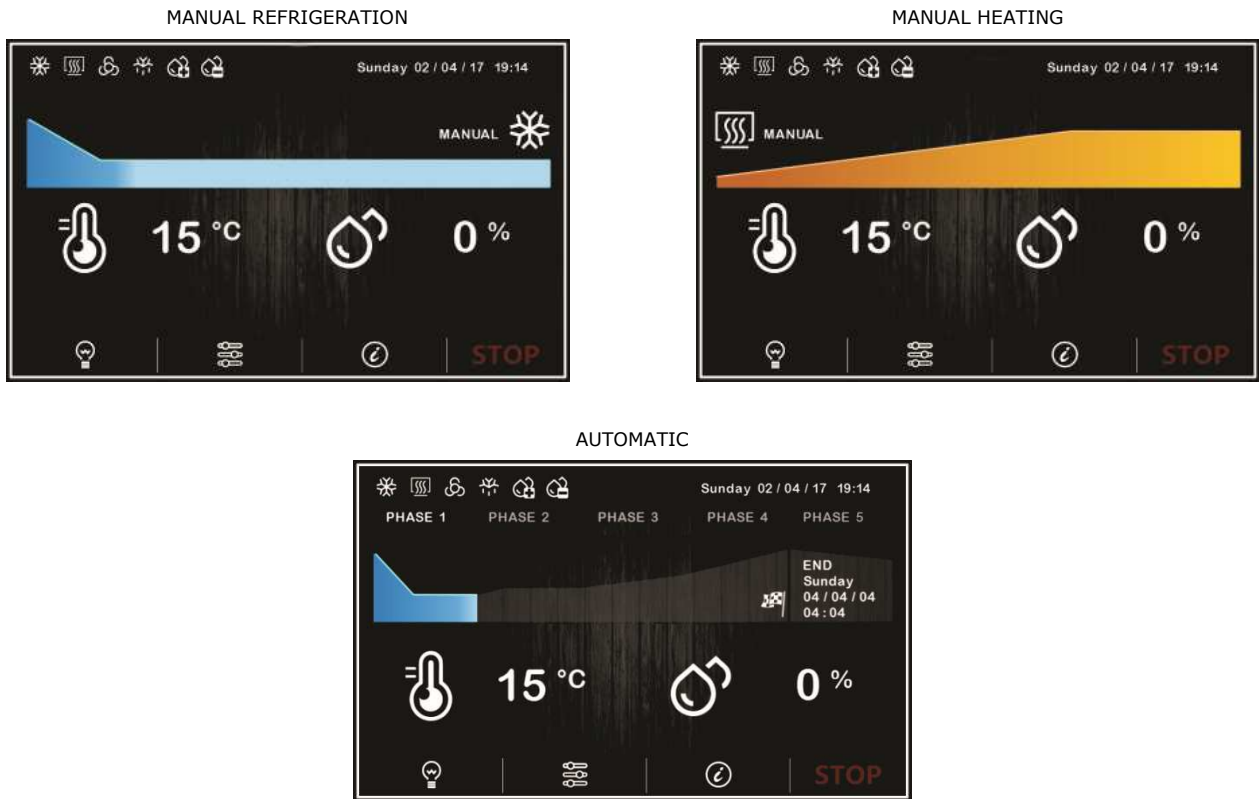

#### 6.3.1 Regulator status icons

While a manual or automatic cycle is being run, the status of the principal loads are displayed as icons on the upper part of the screen. The table below gives their description when switched on

	compressor active
	heating active
	fans working
	Defrosting in progress
	Humidification in progress
	dehumidification in progress
	Alarm in progress

### 6.3.2 Function keys

While a manual or automatic cycle is being run, the lower part of the screen displays the function keys, which are as follows.



switch light on/off



manual commands for changing setpoints and activating manual defrost



display input/output and alarm status

### 6.4 Screen Saver

After a period of inactivity set by parameter E8 (from 1 to 240 minutes), the Run screen will switch to Screen Saver showing the values detected by the probes in use. This function can be disabled by setting parameter E8 to 0.

Just touch the screen to exit the Screen Saver. When an alarm is in progress the Run screen will be restored.



### 6.5 Settings screen

The settings key  on the On/stand-by screen grants access to the Set-up screen with the relevant function menus (for the INPUTS/OUTPUTS STATUS function, data are only displayed). To access the various procedures, touch the screen near the information/function required. The following screen is displayed:

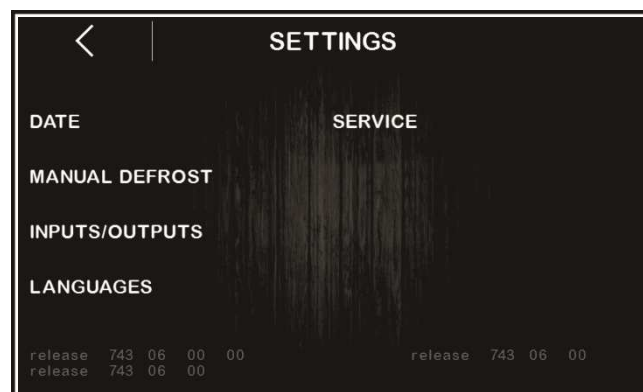

If parameter E12 is set at 1, the screen will also display the configuration details for the serial control humidifier.

### 6.5.1 Service

This option gives access to the following menu

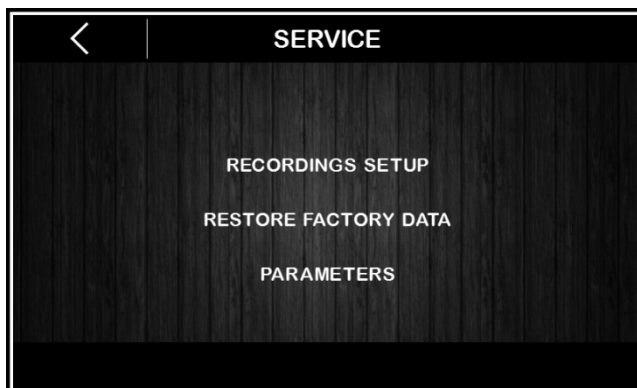

#### RECORDINGS SET-UP

This enables selection of the variables to be recorded for the HACCP history.

#### RESTORE FACTORY DATA

Touching on this option grants access to the following password-protected functions (149):

- Delete records
- Restore default parameters
- Delete recipes

#### PARAMETERS

Touching this option enables configuration of the password-protected parameters (-19). To set parameters follow the navigation instructions given in section 6.1 and configure the machine appropriately consulting the list in section 14 PARAMETERS.

## 7 AN OVERVIEW OF THE FUNCTIONS

### 7.1 Automatic and manual cycles

The controller provides complete control for retarding-proofing cabinets or rooms for bread or pastry-making by managing the complete dough retarding-proofing cycle automatically.

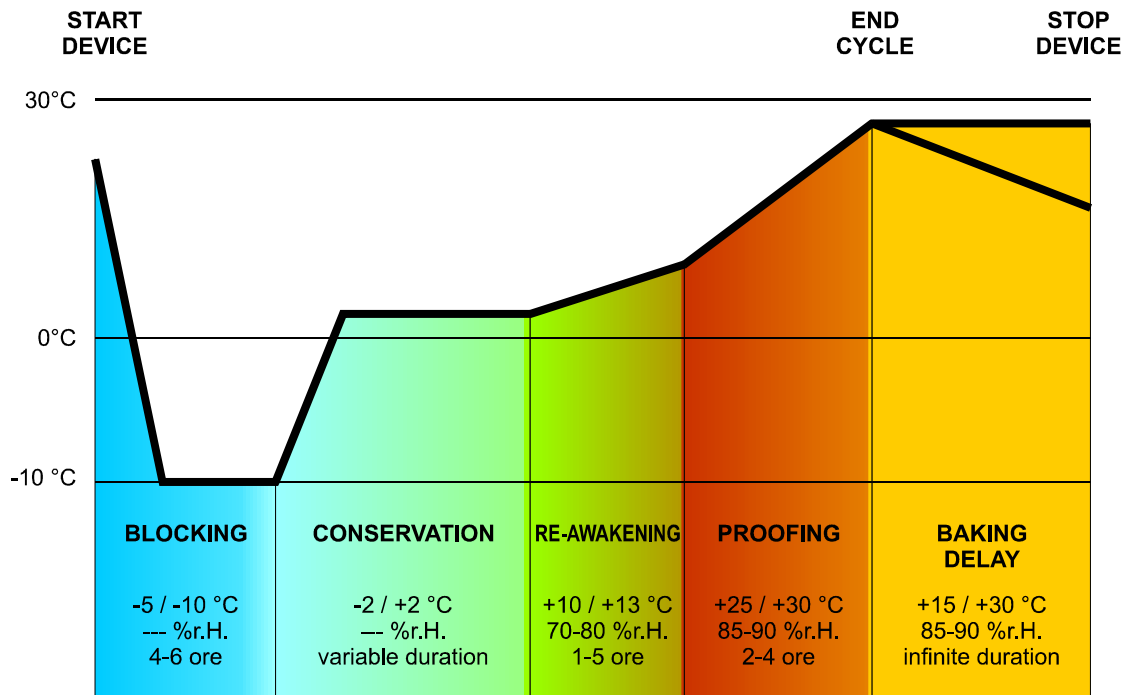

An automatic retarding-proofing cycle consists of 5 different phases with different temperatures, relative humidity, fan speeds and durations, one run after the other in the following order.

#### 1. BLOCKING phase

Temperature regulation is active and has a neutral zone adjustment, the temperature setpoint, the humidity setpoint (if control of this is required), the fan speed and duration in hours and minutes for the phase are set by the end-user.

Relative humidity regulation depends on parameter rU4. If this is set to zero humidity control is not carried out in this phase.

#### 2. CONSERVATION phase

Temperature regulation is active and has a neutral zone adjustment, the temperature setpoint, the humidity setpoint (if control of this is required) and the fan speed are set by the end-user.

Moving from the blocking setpoint (previous phase) to the conservation setpoint can be gradual, with the incremental percentages set while the parameters are being set.

Relative humidity regulation depends on parameter rU4. If this is set to zero humidity control is not carried out in this phase.

The duration of this phase is calculated automatically by the controller on the basis of the duration of the blocking, re-awakening and proofing phases and the day and time for the end of proofing required for the dough.

#### 3. RE-AWAKENING phase

Temperature regulation is active and has a NEUTRAL ZONE adjustment, the working setpoint is set by the end-user. Moving from the conservation setpoint (previous phase) to the re-awakening setpoint can be gradual, with the incremental percentages set while the parameters are being set.

Relative humidity regulation is active and has a NEUTRAL ZONE adjustment, the working setpoint is set by the end-user.

The duration in hours and minutes and the evaporator fan speed are set by the end-user.

#### 4. PROOFING phase

Temperature regulation is active and has a NEUTRAL ZONE adjustment, the working setpoint is set by the end-user. Moving from the re-awakening setpoint (previous phase) to the proofing setpoint can be gradual, with the incremental percentages set while the parameters are being set.

Relative humidity regulation is active and has a NEUTRAL ZONE adjustment, the working setpoint is set by the end-user.

The duration in hours and minutes and the evaporator fan speed are set by the end-user.

#### 5. BAKING DELAY phase

The baking delay phase is always disabled but it can be enabled, either when the cycle is being set up or while it is in progress, by the end-user.

Temperature regulation is active and has a NEUTRAL ZONE adjustment, the working setpoint is set by the end-user.

Relative humidity regulation is active and has a NEUTRAL ZONE adjustment, the working setpoint is set by the end-user as is the evaporator fan speed.

Theoretically this phase has an infinite duration as it terminates when the cycle is interrupted by prolonged pressing (for 4 seconds) of the stop key.

Two manual working cycles are also available: a MANUAL REFRIGERATION cycle (equivalent to a conservation cycle but with an infinite duration and without the regulating steps), and a MANUAL HEATING cycle (equivalent to a proofing cycle but with an infinite duration and without the regulating steps).

To make it possible to regulate in these ways, the controller must manage the loads associated with cooling (compressor, evaporator fan, defrost, pump-down solenoid valve), with heating (heater or heat pump working), with humidification (steam generator, humidifier) and with dehumidification (dehumidification by extractor fan or by activating the refrigeration plant). The way each function is regulated is described in subsequent sections.

## **7.2 Other functions**

As well as managing automatic and manual cycles, the controller is able to manage such other functions as:

- pre-cooling
- engage/disengage "baking delay"
- cabinet light
- recipe book with 100 user recipes
- on-board USB port

## 8 MAIN FUNCTIONS

### 8.1 Manual cycle



This area grants access to manual REFRIGERATION or HEATING cycles.

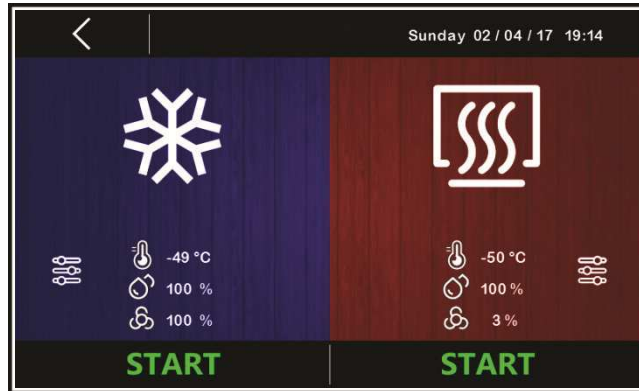

Before starting up the required cycle, press the screen inside the coloured area (blue for REFRIGERATION and red for HEATING) to access all the functions for changing the setpoints for the cycles in question.

Refrigeration setpoint

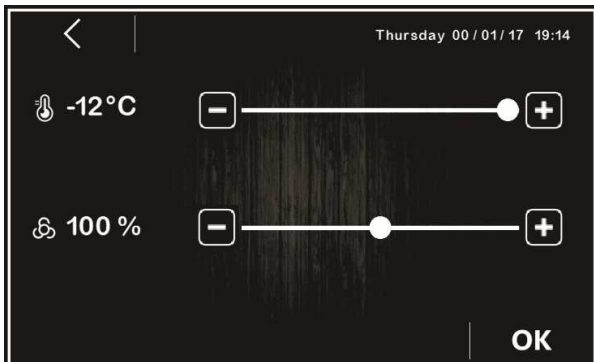

Heating setpoint

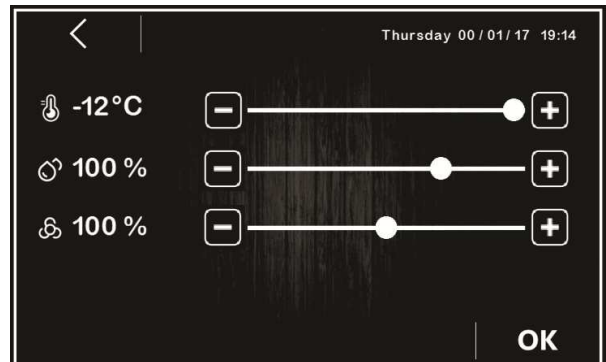

The required cycle is started by pressing the relevant **START** area. To interrupt the cycle hold down **STOP** for 3 seconds.

Refrigeration cycle



Heating cycle



**N.B.** Manual cycles do not allow a duration to be set, they can only be terminated manually by pressing the **STOP** key.



## 8.2 Automatic cycle



### 8.2.1 Start-up and interruption of an automatic cycle

This area grants access to the following screen displaying all the phases making up a RETARDING-PROOFING cycle: blocking, conservation, re-awakening, proofing and baking delay (see section 7 FUNCTIONS).

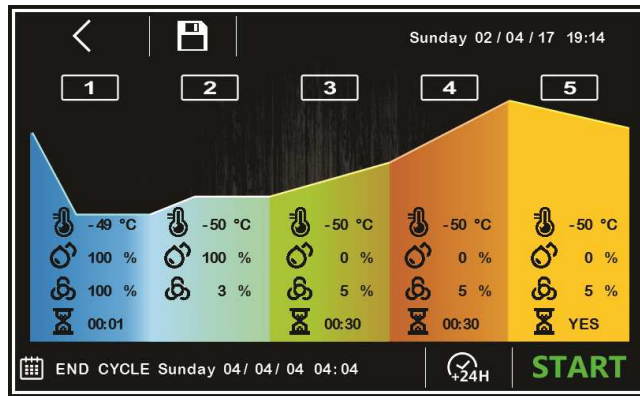

The automatic cycle starts up when the **START** area is pressed and it terminates automatically at the end of phase 4 and according to the time set for it to end, at which time a buzzer sounds.

If the end-time is later than the sum of all the timings for each phase, the controller will automatically increase the conservation time (phase 2) to fill the time gap.

The cycle can be interrupted manually during any phase by holding the **STOP** key down for 4 seconds.

**N.B.** Phase 5 (baking delay) is optional and does not require a duration to be set and therefore, if enabled, it can only be terminated manually by pressing the **STOP** key.



### 8.2.2 Making changes to an automatic cycle

Before starting up a cycle, the setpoint setting menu can be accessed for each of the retarding-proofing phases and pressing the corresponding coloured area will enable changes to be made to the phase in question.

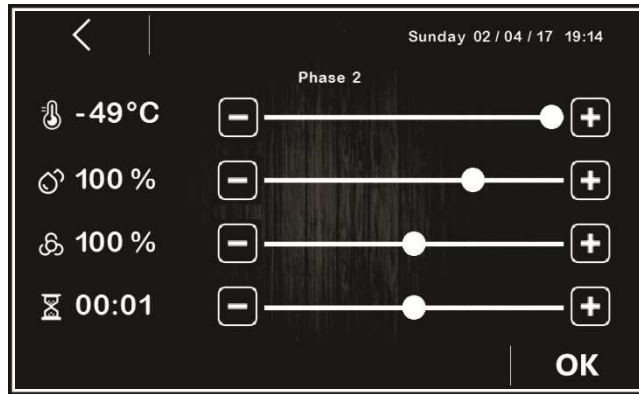

Once OK has been pressed each time to confirm the changes, these will be saved and used as the settings for the automatic cycle which is started up by pressing the **START** area.

The CYCLE END icon is displayed on the bottom left of the screen showing the time set by the user for the end of the cycle, while the date and day of the week are calculated automatically by the controller on the basis of the sum of times set for each individual phase (from phase 1 to phase 4).

Pressing the CYCLE END area makes it possible to change the time of the cycle end and, provided this is confirmed by pressing the REFRESH key, the cycle end date can be changed although this can only be later than the first appropriate date calculated by the controller.

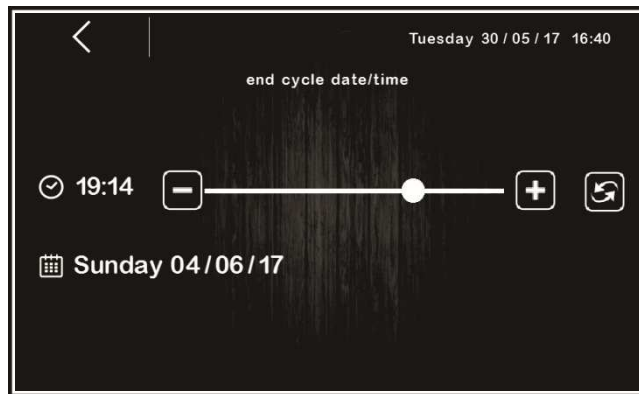

Alternatively, the cycle end date can be postponed using the quick key.

### 8.2.3 Saving an automatic cycle

To name and save the cycles set before their start-up, press the icon, top left and scroll through the pages of the recipe book with the list of recipes using the or keys and choose the desired position in which to save the recipe, giving it a new name or overwriting an existing recipe. When the operation has been completed, press the **OK** key to confirm.



### 8.3 Recipe book



This area grants access to the MY RECIPES screen listing the automatic retarding-proofing cycles saved with the name by the user, following the procedure described in the previous section 7.7.3. Users can save up to 100 recipes.



Press the name of the required recipe to gain direct access to the automatic cycle start-up page, from which it is possible to run a cycle or enter the various phases to change the settings and to create a new recipe from it, which can also overwrite an existing recipe or save it with a different name (see section 7.7.3).

**N.B.** It is not possible to use dashes in memory names and when such a recipe on the list is pressed there will be no effect.

### 8.4 Pre-cooling



This area makes it possible to activate pre-cooling of the cabinet in advance of selection of a retarding-proofing cycle. Pressing the pre-cooling area opens up a screen in which the cabinet temperature setpoint can be regulated, starting the function by pressing the **OK** key.

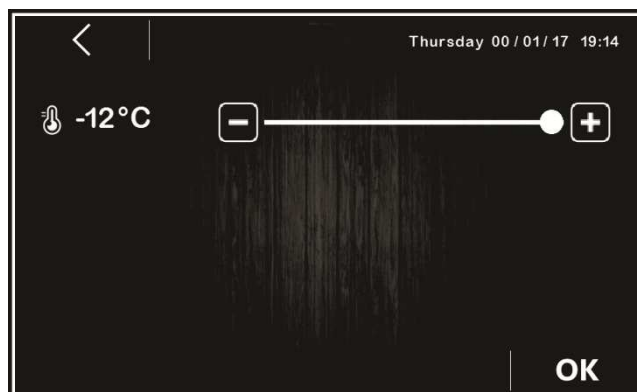

When the function is active, the corresponding area will be coloured blue and the temperature detected in the cabinet will be displayed. Once it first reaches the temperature setpoint, the controller will sound a buzzer. If the temperature in the cabinet is equal to or lower than the setpoint, the pre-cooling function cannot be activated.

The pre-cooling function is of infinite duration and it terminates as soon as a manual or automatic cycle is started up or when it is interrupted by pressing the **STOP** key.



## 9 REGULATIONS

### 9.1 Pre-cooling

The purpose of the pre-cooling cycle is to bring the cabinet to a certain temperature before selecting and running a retarding-proofing cycle.

During a pre-cooling cycle the compressor, condenser fans, pump-down solenoid valve (if enabled) and evaporator fan are working to reach the set temperature.

The pre-cooling setpoint can be changed during the cycle at any time and the new value set will be reused for the next cycle selected.

The pre-cooling cycle continues until the START/STOP key is pressed or until a manual or automatic cycle is started up by the user. Once the pre-cooling temperature has been reached, the buzzer sounds intermittently, indicating that the machine is ready to run the cycle. The buzzer is silenced when any key is pressed or after the time set by parameter E11.

**N.B.** The cycle cannot be run if there is a HIGH PRESSURE, HIGH EVAPORATOR TEMPERATURE, CABINET PROBE, CONDENSER PROBE, HUMIDITY PROBE or THERMAL SWITCH alarm.

### 9.2 Temperature regulation

Temperature regulation for all phases of the machine is in the neutral zone in which two relative values are set one above and one below the temperature setpoint, thus creating a zone inside which the loads for heating and cooling are not activated.

When the temperature rises above the neutral zone value beyond the threshold set by rC0 (cooling differential), the cooling loads are activated until the temperature returns to the neutral zone value.

Similarly, when the temperature falls below the neutral zone value beyond the threshold set by rH0 (heating differential), the heating loads are activated until the temperature returns to the neutral zone value.

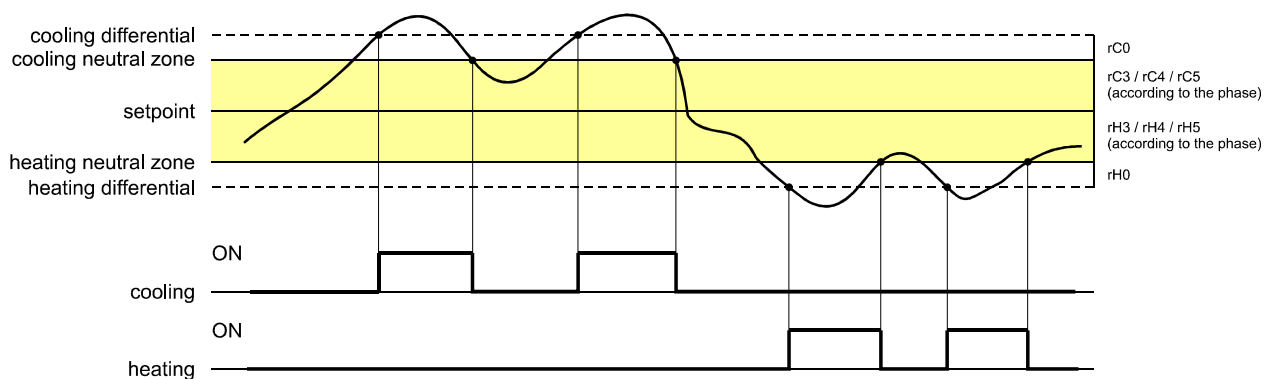

#### 9.2.1 Generating cooling

Cooling is generated by the refrigeration circuit installed in the machine.

When cooling is required the compressor output and the pump-down solenoid valve output (if enabled) are activated.

The evaporator fan operates continuously or in parallel with the compressor, according to how the parameters have been configured for each phase and on the basis of the speed set for the phase in progress.

#### 9.2.2 Generating heat

Heat is generated by a heater.

When heating is required the heater output is activated, with the possibility of running a duty switch on/off cycle (set by parameters rH6 and rH7), so as to limit the heating power if a very powerful heater is being used and thus avoid the cabinet overheating.

The evaporator fan operates continuously or in parallel with the heater output, on the basis of the speed set for the phase in progress.

### 9.3 Humidity regulation

In all phases where this is required, the humidity is regulated with a humidity transducer enabled in the neutral zone in which two values are set one above and one below the humidity setpoint, thus creating a zone inside which the loads for humidification and dehumidification are not activated.

When the humidity rises above the neutral zone value beyond the threshold set by rU5 (dehumidification differential), the dehumidifying loads are activated and they remain active until the humidity returns to the neutral zone value.

Similarly, when the humidity falls below the neutral zone value beyond the threshold set by rU8 (humidification differential), the humidifying loads are activated proportionally and they remain active until the humidity returns to the neutral zone value.

**N.B.** for managing humidity without a transducer, see section 10.7.

#### 9.3.1 Humidification management

Humidification is managed by two different loads: a humidity generator output and a humidifier output.

If parameter E12 is set at 0, the steam generator output remains active during the phases for which humidification management is required. The humidifier output on the other hand, is only activated when the humidity value inside the cabinet falls below the neutral zone value (set by parameter rU9) beyond the threshold set by parameter rU8 (humidification differential). The humidifier output activation time percentage is proportional to the humidity value compared to the proportional humidification band value set by parameter rU10. The activation/deactivation cycle time of the humidification output is set by parameter rU11, while the duration of activation is calculated on the basis of the time set by rU12.

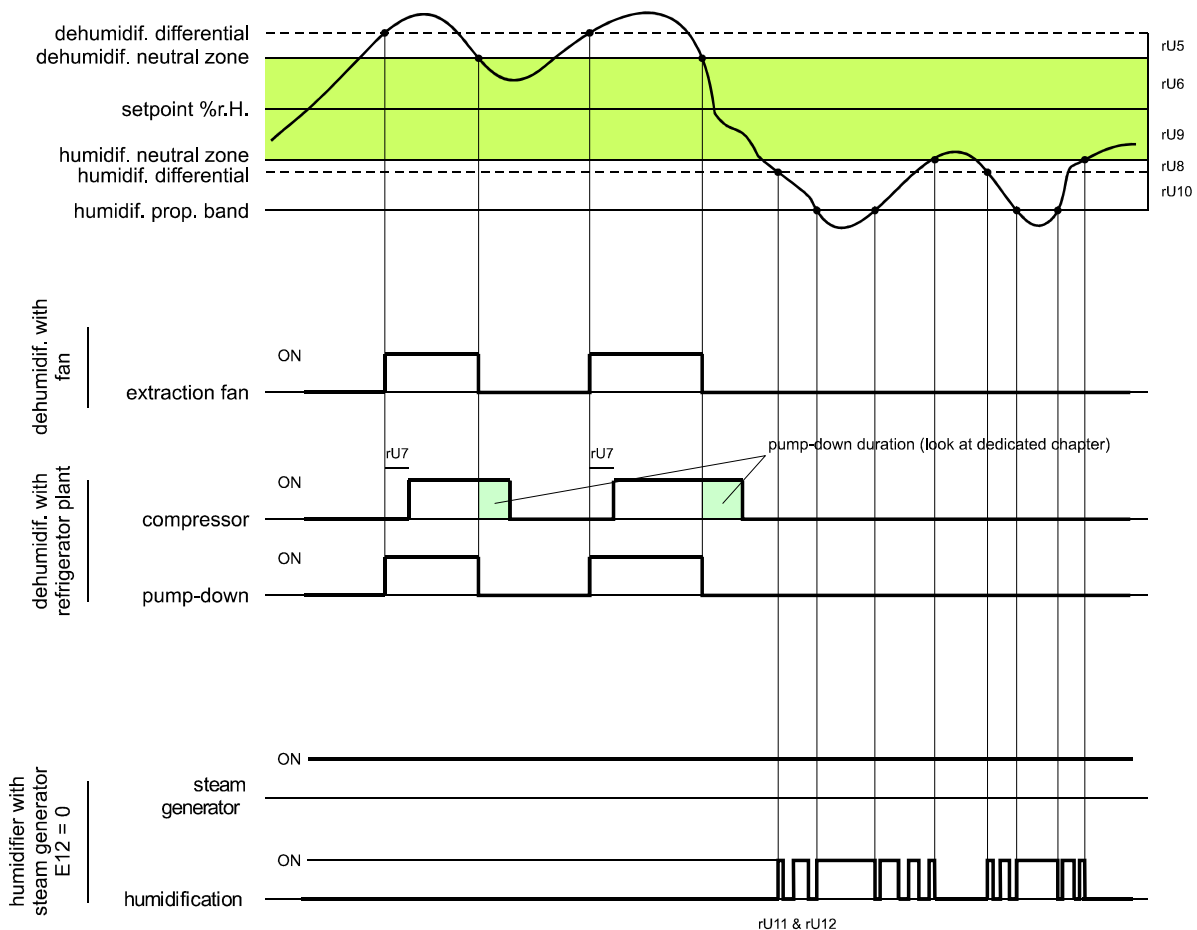

If parameter E12 is set at 1, the steam generator and humidifier outputs are not used because an independent external humidifier with serial control is being used.

If parameter E12 is set at 2, the generator output will only be active when the humidity falls below the neutral zone value (set by parameter rU9) beyond the threshold set by rU8 (humidification differential). However, the humidifier output is activated in on/off cycles when required, always starting at the off time, to allow the steam generator to be ready to generate humidity.

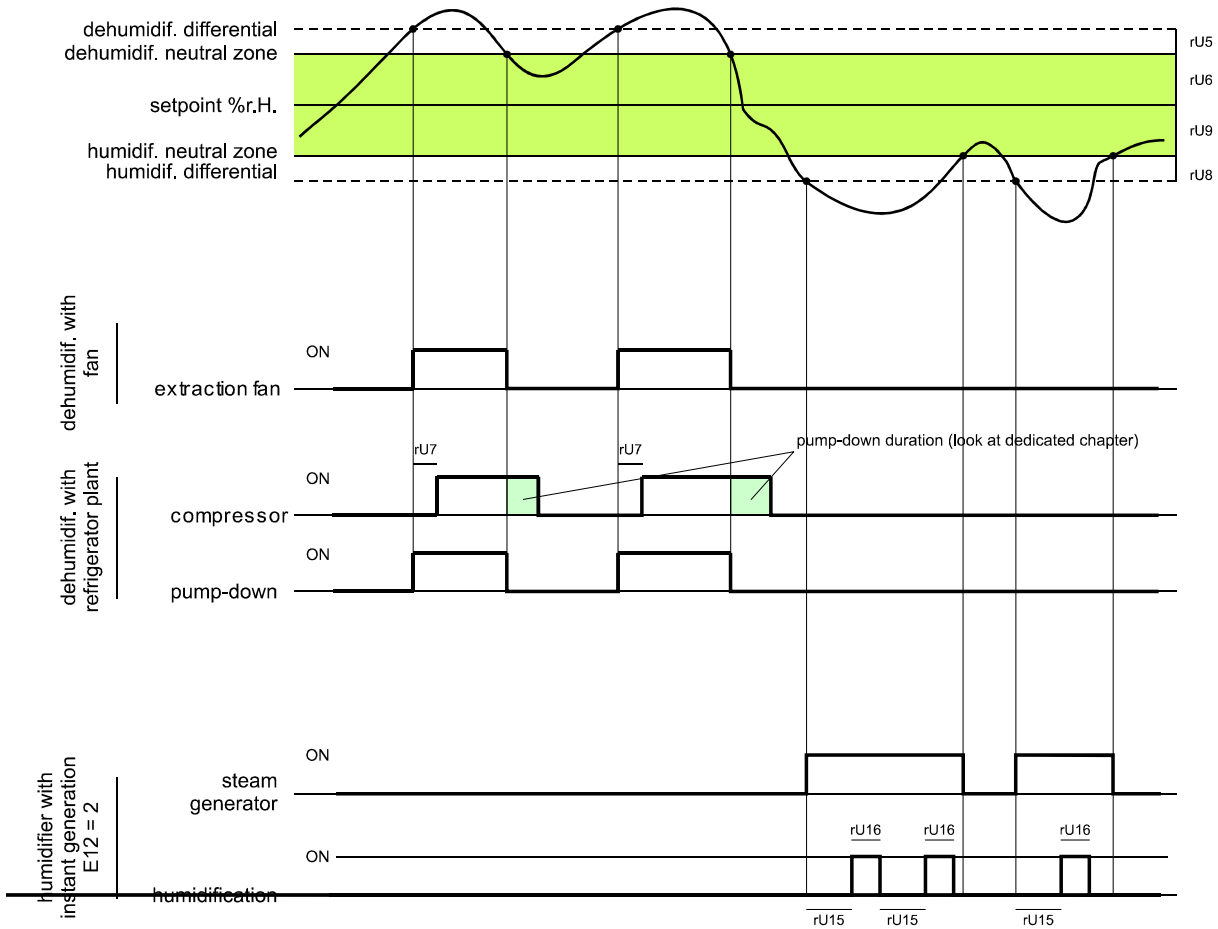

### 9.3.2 Dehumidification management

Dehumidification can be managed in two different ways: using an extractor fan/dehumidifier (u3=0) or by activating the refrigeration plant (u3=1).

When being managed by an extractor fan/dehumidifier, the output will be activated when the humidity rises above the dehumidification neutral zone value (parameter rU6) beyond the threshold set by parameter rU5 (dehumidification differential) and it is deactivated when the humidity returns to within the dehumidification neutral zone value.

The compressor works in the same way if pump-down solenoid valve management is not enabled (parameter u1=1 or 2).

If pump-down solenoid valve management is enabled (parameter u1=0), there will be a first attempt at dehumidification by activating the solenoid valve for a time set by parameter rU7, in an attempt to make use of the high pressure generated during pump-down when the compressor is switched off. Once this time has elapsed, the compressor output will also be activated if further dehumidification is required.

Once the humidity returns to within the dehumidification neutral zone value, the pump-down solenoid valve will be deactivated, after which the compressor will be deactivated by the pump-down algorithm.

## 10 LOAD MANAGEMENT

### 10.1 Compressor management

Activation of the compressor depends on the length of the delay between two switch-ons (parameter C1), on the minimum duration of the compressor-off time (parameter C2), on the delayed switch-on of the compressor from the device power-on (parameter C0) and on the minimum duration of the compressor-on time (parameter C3).

The compressor can also be active during a hot gas defrost (parameter d1 = 1). In this situation, in order for the defrost to start, the compressor must be active for at least the time set by parameter d15.

The compressor can also be used for dehumidification, for more detail see section 10.8.2.

The compressor switch-off is managed differently if management of the pump-down solenoid valve is required. For more detail see the next section.

### 10.2 Pump-down management

If output K8 is configured as a pump-down solenoid valve (parameter u1= 0), the controller will manage the interaction between the compressor output and the solenoid valve output as follows.

With timed pump-down (parameter u1 = 0 and i6 = 0 or 1):

When the compressor is activated the pump-down solenoid valve will be activated in parallel.

The deactivation of the compressor will be preceded by deactivation of the pump-down solenoid valve. After the time set by u2 the compressor output will also be deactivated.

With pump-down managed by digital input LP (parameter u1 = 0 and i6 = 2):

When the compressor is activated the pump-down solenoid valve will be activated in parallel.

The deactivation of the compressor will be preceded by deactivation of the pump-down solenoid valve. The compressor will then be switched off by the action of digital input LP.

If there is no action of the digital input LP within the maximum time set by u2, the compressor will be deactivated and the PUMP DOWN alarm will be activated. Any HIGH PRESSURE alarm will turn off the compressor apart from the pump-down management.

If pump-down is managed by digital input LP, each time the compressor and solenoid valve output are switched on a re-arm time will be loaded for digital input LP (parameter i9). When the compressor is switched off the status of digital input LP will not be affected.

### 10.3 Evaporator fan management

The evaporator fan is managed by the analogue output PWM (to be teamed with the phase cutting module EVDFAN1) or by the digital output K8 in On/Off mode if parameter u1 = 1.

The evaporator fan can be configured for each phase in the cycle to work continuously or in parallel with the regulation output, that being in parallel with the compressor, the heater, humidification and dehumidification. The way it behaves is set by parameters from F0 to F4.

It will also be possible to set a regulation output delay at the fan deactivation using parameter F13 and a duty-cycle with a cycle time and On time set by parameters F14 and F15 during deactivation of the main load. If parameters F14 and F15 are set to zero, there will be no activation.

During refrigeration phases (blocking, conservation and manual refrigeration) the fan will only be active when the evaporator temperature is below the value set by parameter F25.

If the evaporator fan is being managed by analogue output PWM, it will also be possible to set the fan speed for each phase.

When the fan is switched on the controller manages its speed (F21) and a start-up time (F22). When the start-up phase ends, the fan speed will keep to the speed set for the phase in progress, compensated between parameters F23 and F24 that set the minimum and maximum fan speed respectively.

During a defrost cycle the fan is in OFF mode. At the end of the defrost cycle the evaporator fan will remain off for the drip time set by parameter d7 and the subsequent evaporator fan-stop time set by parameter F12.



Evaporator fan calibration procedure managed by the TDF module.

To adapt the phase-cutting regulation to all types of 230 VAC single-phase motors, a manual evaporator fan calibration procedure is recommended.

1. Set F23 at 0% and F24 at 100%.
2. Carry out a manual cycle and vary the fan speed, check the minimum percentage below which the fan switches off and the maximum percentage above which the fan runs at maximum.
3. Set these values for F23 and F24 respectively.



## 10.4 Defrost management

Defrost is active during the automatic BLOCKING and CONSERVATION phases and during the MANUAL REFRIGERATION phase and it can be either automatic (time intervals) or manual. Manual defrost can be activated by accessing the relevant menu on the On/standby screen by pressing the  key or during a cycle, by the function key  on the lower part of the screen.

Depending on the value of parameter d1, the machine will perform either electric or hot gas defrost cycles.

If the evaporator probe is enabled (parameter P3=1), the defrost will end when it reaches the end-of-defrost temperature (parameter d2) within a maximum time interval set by parameter d3. If the evaporator probe is not enabled (P3=0) or if it is out of order, defrost will end at the time set by parameter d3.

At the end of a defrost cycle the controller will allocate a drip time (d7) during which all the regulation outputs will be switched off. When the dripping time finishes, the refrigeration plant will begin working again but activation of the evaporator fan will be further delayed by the time set by parameter F12.

If a hot gas defrost is being carried out, in order for the defrost to start, the compressor must be activated for at least the time set by parameter d15.

## 10.5 Heater management

When heat is required, the heater output will be activated, also making it possible to manage a switch-on and off duty-cycle being controlled by parameters rH6 and rH7.

### 10.5.1 Cabinet step heating management

The required setpoint in the re-awakening and proofing phases can be reached gradually, setting the number of steps for reaching the setpoint and the setpoint percentage increase for each step.

In the re-awakening phase, the number of steps is set by parameter rr0, while the setpoint percentage increases are set by parameters from rr1 to rr10.

In the proofing phase, the number of steps is set by parameter rL0, while the setpoint percentage increases are set by parameters from rL1 to rL10.

**N.B.** The user is required to check the consistency of the number of steps set and the correct number of setpoint percentage increases. e.g. if rr0 equals 4, only parameters from rr1 to rr4 are to be set.

**N.B.** If the setpoint is changed while the cycle is in progress, the steps are disabled.

## 10.6 Steam generator output management

Management of the steam generator load depends on the setting of parameter E12.

If E12=0: the steam generator output remains active during all the phases in which cabinet humidification is required.

If E12=1: the output is not managed

If E12=2: the steam generator output is active when the setting requires humidification

## 10.7 Humidifier output management

The humidifier load can be managed with or without the use of a humidity transducer (parameter rU0) and it varies according to the type of humidifier selected (parameter E12).

**N.B.** if E12 = 1, the output is not managed.

### 10.7.1 Managing the humidifier output without a transducer (rU0 = 1, E12 = 0 or 2)

In this situation, the humidifier output will remain active for a duty-cycle that varies according to the humidity setpoint for the phase in progress.

The output activation and deactivation duration is set by parameter rU2 (humidification cycle time) and the maximum humidification time needed to obtain 100% humidity within the cabinet (rU3).

The humidification switch-on/off times will be proportional on the basis of the humidity setpoint percentage according to parameter rU3, and they will be repeated for every cycle time set by rU2.

### **10.7.2 Managing the humidifier output with a transducer and a humidifier with a steamer (rU0 = 0, E12 = 0)**

The humidifier output is activated when the humidity value inside the cabinet falls below the neutral zone value (rU9) beyond the threshold set by the humidification differential (rU8).

The duration of the humidifier output activation is proportional to the humidity value compared to the proportional humidification band value set by parameter rU10.

Parameter rU11 sets the cycle time, while parameter rU12 represents the time base used to calculate the output activation duration.

### **10.7.3 Managing the humidifier output with a transducer and an instant generation humidifier (rU0 = 0, E12 = 2)**

The humidifier output is activated when the humidity value inside the cabinet falls below the neutral zone value (rU9) beyond the threshold set by the humidification differential (rU8) performing off/on cycles, the duration being set by parameters rU15 and rU16. The count always starts from the off time.

## **10.8 Dehumidification management**

Dehumidification management is only active when humidity is managed by a humidity transducer (rU0 = 0).

Dehumidification can be managed in two different ways: using an extractor fan (parameter u3 = 0, load associated with output K4) or by activating the refrigeration plant (compressor and pump-down solenoid valve, if present).

### **10.8.1 Management using an extractor fan/dehumidifier**

When managed by an extractor fan/dehumidifier, the output will be activated when the humidity rises above the dehumidification neutral zone value (rU6) plus the differential value (rU5) and it is deactivated when the humidity returns to within the dehumidification neutral zone value.

### **10.8.2 Management by activating the refrigeration plant**

The compressor works in the same way if pump-down solenoid valve management is not enabled.

If, however, pump-down solenoid valve management is enabled, there will be a first attempt at dehumidification by activating the pump-down solenoid valve (to make use of the high pressure generated when the compressor is switched off), for a time period set by rU7. After this time has elapsed, the compressor output will be activated.

Once the humidity returns to within the dehumidification neutral zone value, the pump-down solenoid valve will be deactivated, after which the compressor will be deactivated by the pump-down algorithm.

## **10.9 Condenser fan management**

If parameter u3 is set to 1, output K4 will take over condenser fan control.

If the condenser probe is enabled (parameter P4 = 1), the condenser fan will activate when the condenser temperature rises above the value of parameter F16 plus the differential value (F16 + 2.0 °C / 4 °F), regardless of compressor status, while it will always be on when the compressor is on.

The condenser fan will switch off when the condenser temperature falls below the value of parameter F16.

If the condenser probe is disabled (parameter P4 = 0), the condenser fan will activate in parallel with the compressor, while deactivation will be delayed for the time set by parameter F17.

During CONDENSER OVERHEAT or COMPRESSOR LOCKED alarm, the condenser fan will stay on.

During defrost the fans will be switched off.

## **10.10 Cabinet light management**

The cabinet light will switch-on/off by opening/closing the door or by pressing the  key while manual and/or automatic cycles are being performed.

## 11 MANAGING THE USB PORT

The USB port provides the following functions:

- download to a USB flash drive the data relating to the cycles performed (HACCP history)
- download to a USB flash drive the recipes saved in the controller
- download to a USB flash drive the parameters saved in the controller
- upload to the controller the recipes in the USB flash drive
- upload to the controller the parameters in the USB flash drive

Before inserting the flash drive into the USB port on the machine, switch to the On/standby screen and the menu shown below will appear.

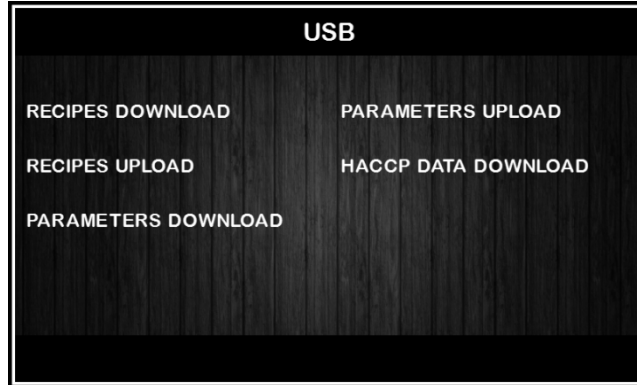

To download historical data select the date to begin downloading HACCP data.

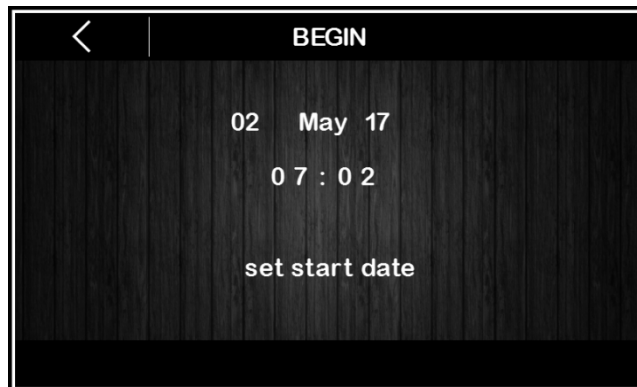

## 12 ALARMS

An alarm event is signalled by a prolonged buzzer sound and it can be seen when the  icon appears on the upper part of the screen. The type of alarm is shown in text on the lower part of the screen. The text does not appear on the settings page and if an alarm situation happens while the display is in screen-saver mode, the menu currently in use appears on the display.

To silence the buzzer, touch the screen at any point, while to remove the signal icon touch the screen over this and access the page listing the alarms on which those that are active are shown with the word ON alongside.

The table below lists the alarms that may be signalled.

Alarm	Description
<b>EVAPOR. HIGH TEMP.</b>	<p>Maximum evaporator temperature alarm</p> <p>To correct</p> <ul style="list-style-type: none"> <li>- Check the evaporator temperature</li> <li>- Check the value of parameters A1 and A2.</li> </ul> <p>Main results</p> <ul style="list-style-type: none"> <li>- All loads are deactivated</li> </ul>
<b>CABINET HIGH TEMP.</b>	<p>Maximum cabinet temperature alarm</p> <p>To correct</p> <ul style="list-style-type: none"> <li>- Check the cabinet temperature</li> <li>- Check the value of parameters A3 and A4.</li> </ul> <p>Main results</p> <ul style="list-style-type: none"> <li>- All loads are deactivated until alarm stops</li> <li>- The alarm indication will disappear only by touching the alarm area.</li> </ul>
<b>DOOR OPEN</b>	<p>Door open alarm.</p> <p>To correct</p> <ul style="list-style-type: none"> <li>- Check the door status.</li> <li>- Check the value of parameters i0, i1 and i2.</li> </ul> <p>Main results</p> <ul style="list-style-type: none"> <li>- The effect set by parameter i0.</li> </ul>
<b>HIGH PRESSURE</b>	<p>High pressure alarm.</p> <p>To correct</p> <ul style="list-style-type: none"> <li>- Check the state of the high pressure input.</li> <li>- Check the value of parameters i3, i4 and i5.</li> </ul> <p>Main results</p> <ul style="list-style-type: none"> <li>- The effect set by parameter i3.</li> </ul>
<b>LOW PRESSURE</b>	<p>Low pressure alarm.</p> <p>To correct</p> <ul style="list-style-type: none"> <li>- Check the state of the low pressure input.</li> <li>- Check the value of parameters i6, i7, i8 and i9.</li> </ul> <p>Main results</p> <ul style="list-style-type: none"> <li>- Compressor and condenser fan are switched off</li> </ul>
<b>COMP. THERMAL SWITCH</b>	<p>Compressor thermal switch alarm.</p> <p>To correct</p> <ul style="list-style-type: none"> <li>- Check the state of the compressor thermal switch input.</li> <li>- Check the value of parameters i16, i7 and i8.</li> </ul> <p>Main results</p> <ul style="list-style-type: none"> <li>- Compressor is switched off</li> </ul>
<b>THERMAL SWITCH</b>	<p>Compressor thermal switch alarm.</p> <p>To correct</p> <ul style="list-style-type: none"> <li>- Check the state of the thermal switch input.</li> <li>- Check the value of parameters i10 and i11.</li> </ul> <p>Main results</p>

	- All loads are deactivated
<b>POWER FAILURE</b>	Power failure during a cycle run alarm. To correct - Check the device-power supply connection.
<b>CONDENSER OVERHEAT</b>	Condenser overheat alarm. To correct - Check the condenser temperature - Check the value of parameter C6. Main results - The condenser fan will be switched on.
<b>COMPRESSOR LOCKED</b>	Compressor locked alarm. To correct - Check the condenser temperature - Check the value of parameters C7 and C8. - Disconnect the device from the power supply and clean the condenser. Main results - If the error happens during an operating cycle, the cycle will be interrupted.
<b>PUMP DOWN</b>	Pump down alarm To correct - Check the maximum pump-down time set by parameter u2 - The alarm will be re-armed when the compressor is next activated or by pressing the buzzer silencing key Main results - Compressor switched off
<b>CABINET PROBE</b>	Cabinet probe error. To correct - Check the parameter P0 value - Check probe integrity - Check the device-probe connection - Check the cabinet temperature. Main results - If the error happens during "stand-by", it will not be possible to start up an operating cycle. - If the error happens during a cycle, the cycle will be interrupted.
<b>EVAPORATOR PROBE</b>	Evaporator probe error. To correct - The same as for the cabinet probe error but with reference to the evaporator probe. Main results - If parameter P3 is set to 1, defrosting will last for the time set by parameter d3.
<b>CONDENSER PROBE</b>	Condenser probe error. To correct - The same as for the cabinet probe error but with reference to the condenser probe. Main results - The condenser fan will operate in parallel with the compressor. - The condenser overheat alarm will never be activated. - The compressor locked alarm will never be activated.
<b>HUMIDITY PROBE</b>	Humidity transducer error. To correct - Check transducer integrity

	<ul style="list-style-type: none"> <li>- Check the device-transducer connection.</li> <li>- Check cabinet relative humidity.</li> </ul> <p>Main consequences if parameter rU0 is set to 0:</p> <ul style="list-style-type: none"> <li>- If the error happens during "stand-by", it will not be possible to start up humidity management cycles.</li> <li>- If the error happens during a humidity control cycle, the cycle will be interrupted.</li> </ul>
<b>RTC</b>	<p>Clock error.</p> <p>To correct</p> <ul style="list-style-type: none"> <li>- Re-set the date and time.</li> </ul> <p>Main results</p> <ul style="list-style-type: none"> <li>- The device is unable to start up automatic cycles</li> <li>- Any automatic cycles in progress will be blocked.</li> </ul>
<b>POWER BOARD INCOMPATIBILITY</b>	<p>User interface-control module compatibility error.</p> <p>To correct</p> <ul style="list-style-type: none"> <li>- Check that the user interface and the control module are compatible.</li> </ul> <p>Main results</p> <ul style="list-style-type: none"> <li>- Cycle in progress interrupted.</li> </ul>
<b>NO COMMUNICATION</b>	<p>User interface-control module communication error.</p> <p>To correct</p> <ul style="list-style-type: none"> <li>- Check the user interface-control module connection.</li> </ul> <p>Main results</p> <ul style="list-style-type: none"> <li>- Cycle in progress interrupted.</li> </ul>
<b>ESP INCOMPATIBILITY</b>	<p>Humidifier user interface compatibility error with the EASYSTEAM serial control <b>(if E12 = 1)</b>.</p> <p>To correct</p> <ul style="list-style-type: none"> <li>- Check that the user interface and the humidification module are compatible.</li> </ul>
<b>NO ESP COMMUNICATION</b>	<p>Humidifier user interface with EASYSTEAM serial control communication error <b>(if E12 = 1)</b>.</p> <p>To correct</p> <ul style="list-style-type: none"> <li>- Check the user interface-humidification module connection.</li> </ul>
<b>H Exx</b>	<p>Errors arising from the humidifier with EASYSTEAM serial control <b>(if E12 = 1)</b>.</p> <p>To correct</p> <ul style="list-style-type: none"> <li>- Check the manual for the humidifier with EASYSTEAM serial control.</li> </ul>

### 13 EPOCA CLOUD PLATFORM

EPoCA is a remote monitoring system based on a cloud platform. All that is needed is a simple onsite Wi-Fi internet connection to enable the controller, using EVlink Wi-Fi module, to connect to the cloud system, making it possible to remotely manage equipment from a PC, tablet or smartphone.

The responsive design and the graphic interface conceived to provide a pleasant user experience make EPoCA a ready-to-use solution for easily accessible monitoring operations, even for entry-level users, while offering all the typical functions of professional platforms. With appropriate protection measures for access and data, the system makes it possible for one or more enabled users to operate remotely on the unit to configure its parameters, view HACCP data (also in graphic form) and to download records in the most popular formats, such as XLSX, CSV and PDF. The functions playing a key role include alarm warnings sent automatically by the system to selected e-mail addresses.

Schematic diagram:

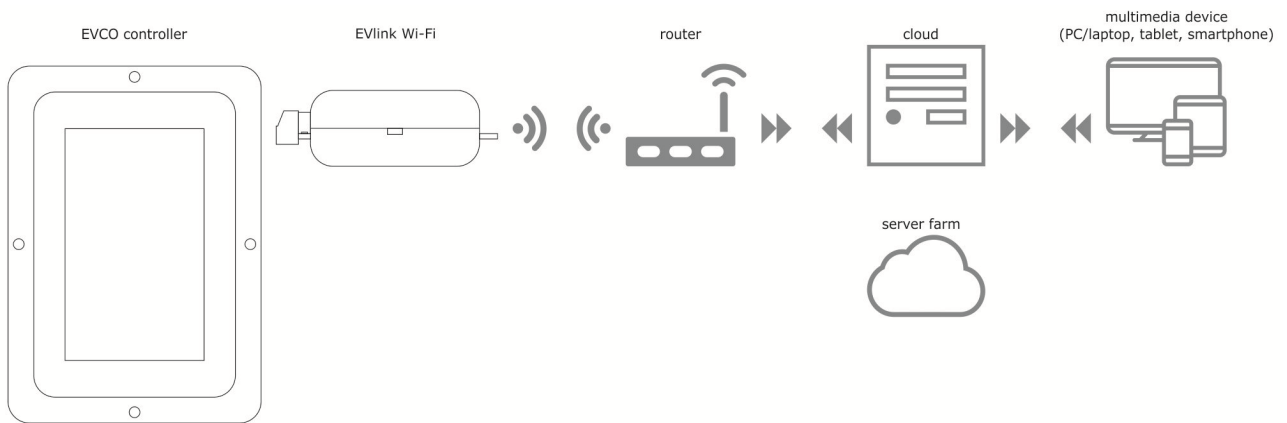

For more details on the EVlink Wi-Fi module and on the EPoCA cloud platform, please check out the "EPoCA" manual in our website [www.evco.it](http://www.evco.it).

## 14 PARAMETERS

The table below describes the configuration parameters of the device.

Par.	Min.	Max.	Unit	Default	Analogue inputs
CA1	-25	25	°C	0	Cabinet probe offset
CA2	-25	25	°C	0	Evaporator probe offset
CA3	-25	25	°C	0	Condenser probe offset
CA4	-25	25	% r.H.	0	Humidity probe offset
P0	0	1	----	1	Type of probe 0 = PTC 1 = NTC
P2	0	1	----	0	Temperature measurement unit 0 = °C 1 = °F
P3	0	1	----	1	Enable evaporator probe 0 = Disabled 1 = Enabled
P4	0	1	----	0	Enable condenser probe 0 = Disabled 1 = Enabled
P5	0	60	min	15	Duration of the power failure above which the cycle is interrupted
P6	----	----	----	----	Not used
P7	0	P8	% r.H.	0	Lower calibration limit of the humidity transducer (corresponding to 4 mA)
P8	P7	100	% r.H.	100	Upper calibration limit of the humidity transducer (corresponding to 20 mA)
Par.	Min.	Max.	Unit	Default	Cooling regulator
rC0	1	15	°C	2	Parameter rC3, rC4, rC5 differential
rC1	-99	rC2	°C	-20	Minimum possible setpoint for the blocking, conservation, refrigeration and manual pre-cooling
rC2	rC2	99	°C	20	Maximum possible setpoint for the blocking, conservation, refrigeration and manual pre-cooling
rC3	0	10	°C	1	Value of cooling neutral zone for the blocking, conservation and manual refrigeration phases
rC4	0	10	°C	1	Value of cooling neutral zone for the re-awakening, proofing and manual heating phases
rC5	0	10	°C	1	Value of cooling neutral zone for the baking delay phase
rC6	-99	99	°C	2	Pre-cooling setpoint
					<b><u>N.B. for parameters rC7 to rC10</u></b> The controller will not carry out an automatic adaptation of the percentages set. Check that the settings for the percentages and number of steps are consistent.
rC7	1	3	----	1	Number of regulation steps for the conservation phase
rC8	1	100	%	20	Percentage increase for the 1 <sup>st</sup> conservation step (out of a total of 100%)



rC9	1	100	%	50	Percentage increase for the 2 <sup>nd</sup> conservation step (out of a total of 100%)
rC10	1	100	%	100	Percentage increase for the 3 <sup>rd</sup> conservation step (out of a total of 100%)
<b>Par.</b>	<b>Min.</b>	<b>Max.</b>	<b>Unit</b>	<b>Default</b>	<b>Heating regulator</b>
rH0	1	15	°C	2	Parameter rH3, rH4, rH5 differential
rH1	-99	rH2	°C	0	Minimum possible setpoint for the re-awakening, proofing, baking delay and manual heating phases
rH2	rH2	99	°C	40	Maximum possible setpoint for the re-awakening, proofing, baking delay and manual heating phases
rH3	0	10	°C	1	Value of heating neutral zone for the blocking, conservation and manual refrigeration phases
rH4	0	10	°C	1	Value of heating neutral zone for the re-awakening, proofing and manual heating phases
rH5	0	10	°C	1	Value of heating neutral zone for the baking delay phase
rH6	1	600	s	60	Cycle time for heater switch-on if heating is required (see also rH7)
rH7	1	600	s	45	Heater switch-on time within the rH6 cycle time
					<b><u>N.B. for parameters rr0 to rL10</u></b> <u>The controller will not carry out an automatic adaptation of the percentages set. Check that the settings for the percentages and number of steps are consistent.</u>
rr0	1	10	- - - -	4	Number of regulation steps for the re-awakening phase
rr1	1	100	%	25	Percentage increase for the 1 <sup>st</sup> re-awakening step (out of a total of 100%)
rr2	1	100	%	50	Percentage increase for the 2 <sup>nd</sup> re-awakening step (out of a total of 100%)
rr3	1	100	%	75	Percentage increase for the 3 <sup>rd</sup> re-awakening step (out of a total of 100%)
rr4	1	100	%	100	Percentage increase for the 4 <sup>th</sup> re-awakening step (out of a total of 100%)
rr5	1	100	%	- - - -	Percentage increase for the 5 <sup>th</sup> re-awakening step (out of a total of 100%)
rr6	1	100	%	- - - -	Percentage increase for the 6 <sup>th</sup> re-awakening step (out of a total of 100%)
rr7	1	100	%	- - - -	Percentage increase for the 7 <sup>th</sup> re-awakening step (out of a total of 100%)
rr8	1	100	%	- - - -	Percentage increase for the 8 <sup>th</sup> re-awakening step (out of a total of 100%)
rr9	1	100	%	- - - -	Percentage increase for the 9 <sup>th</sup> re-awakening step (out of a total of 100%)
rr10	1	100	%	- - - -	Percentage increase for the 10 <sup>th</sup> re-awakening step (out of a total of 100%)
rL0	1	10	- - - -	4	Number of steps for heater regulation for the proofing phase
rL1	1	100	%	25	Percentage increase for the 1 <sup>st</sup> proofing step (out of a total of 100%)

rL2	1	100	%	50	Percentage increase for the 2 <sup>nd</sup> proofing step (out of a total of 100%)
rL3	1	100	%	75	Percentage increase for the 3 <sup>rd</sup> proofing step (out of a total of 100%)
rL4	1	100	%	100	Percentage increase for the 4 <sup>th</sup> proofing step (out of a total of 100%)
rL5	1	100	%	- - - -	Percentage increase for the 5 <sup>th</sup> proofing step (out of a total of 100%)
rL6	1	100	%	- - - -	Percentage increase for the 6 <sup>th</sup> proofing step (out of a total of 100%)
rL7	1	100	%	- - - -	Percentage increase for the 7 <sup>th</sup> proofing step (out of a total of 100%)
rL8	1	100	%	- - - -	Percentage increase for the 8 <sup>th</sup> proofing step (out of a total of 100%)
rL9	1	100	%	- - - -	Percentage increase for the 9 <sup>th</sup> proofing step (out of a total of 100%)
rL10	1	100	%	- - - -	Percentage increase for the 10 <sup>th</sup> proofing step (out of a total of 100%)
<b>Par.</b>	<b>Min.</b>	<b>Max.</b>	<b>Unit</b>	<b>Default</b>	<b>Humidity regulator</b>
rU0	0	1	- - - -	0	Humidity management mode: 0 = with humidity probe 1 = without the humidity probe, time intervals based on the percentage set
rU1	-99	99	°C	0	Minimum cabinet temperature for inhibiting humidification control
rU2	1	600	s	60	Cycle time for humidifier switch-on (only for rU0 = 1, see also rU3)
rU3	1	600	s	30	Humidifier switch-on time within rU2 cycle time to generate 100% humidity in cabinet (only for rU0 = 1, see also rU2)
rU4	0	2	- - - -	0	Enable humidification/dehumidification control during the blocking, conservation and manual refrigeration phases 0 = the humidification/dehumidification control is disabled but the humidity probe reading is shown 1 = the humidification/dehumidification control is enabled 2 = the humidification/dehumidification control is disabled and the humidity probe reading is not shown (the device shown the indication "- - -")
rU5	1	100	%r.H.	5	Dehumidification differential
rU6	0	100	%r.H.	2	Dehumidification neutral zone value
rU7	0	255	s	10	Duration of dehumidification attempt with pump-down solenoid valve
rU8	1	100	%r.H.	5	Humidification differential
rU9	0	100	%r.H.	2	Humidification neutral zone value
rU10	0	50	%r.H.	10	Humidification proportional band value (only for E12=0)
rU11	0	255	s	30	Cycle time for humidification proportional regulation (only for E12=0)
rU12	0	1	- - - -	0	Time base for humidification proportional regulation cycle time (only for E12=0): 0 = seconds 1 = minutes
rU13	0	100	%	80	Maximum humidity set point that can be set
rU14	-99	99	°C	0	Minimum cabinet temperature for inhibiting dehumidification control
rU15	0	300	s	60	Humidifier pause time (only if E12=2)
rU16	0	60	s	3	Humidifier activation time (only if E12=2)
<b>Par.</b>	<b>Min.</b>	<b>Max.</b>	<b>Unit</b>	<b>Default</b>	<b>Compressor protection</b>
C0	0	240	min	0	Compressor switch-on delay from device switch-on

C1	0	240	min	2	Delay between two compressor switch-ons
C2	0	240	min	0	Minimum compressor-off duration
C3	0	240	s	0	Minimum compressor-on duration
C4	0	240	min	0	Forced compressor-on time at the beginning of the re-awakening, proofing and baking delay phases
C6	0	199	°C	70	Condensation temperature above which the condenser overheat alarm sounds
C7	0	199	°C	80	Condensation temperature above which the compressor locked alarm sounds
C8	0	15	min	1	Compressor locked alarm delay
Par.	Min.	Max.	Unit	Default	Defrost
d0	0	99	h	6	Automatic defrost interval 0 = defrost at intervals is never activated.
d1	0	1	----	0	Type of defrost 0 = electrical (during defrosting the compressor is switched off, the defrost output is activated and the evaporator fan switched off). 1 = hot gas (during defrosting the compressor is switched on, the defrost output is activated and the evaporator fan is switched off).
d2	-99	99	°C	8	Defrost end threshold (evaporator temperature); see also parameter d3
d3	0	99	min	30	If parameter P3 is set at 0, defrost duration If parameter P3 is set to 1, maximum defrost duration; see also parameter d2 0 = defrost is never activated.
d5	0	99	min	30	Defrost delay from the beginning of conservation/manual refrigeration 0 = defrost will be activated once the time set by d0 has elapsed.
d7	0	15	min	2	Drip time (during dripping the compressor and evaporator fan will remain off and the defrost output will be deactivated)
d15	0	99	min	0	Minimum consecutive compressor-on duration for starting hot gas defrost when defrost interval elapses (only if parameter d1 is set at 1)
Par.	Min.	Max.	Unit	Default	Temperature alarms
A1	0	99	°C	70	Evaporator temperature above which the evaporator high temperature alarm is activated; see also parameter A2
A2	-1	240	min	1	Evaporator high temperature alarm delay 1 = yes -1 = alarm disabled
A3	0	99	°C	70	Cabinet temperature above which the cabinet high temperature alarm is activated; see also parameter A4
A4	-1	240	min	1	Cabinet high temperature alarm delay 1 = yes -1 = alarm disabled
Par.	Min.	Max.	Unit	Default	Evaporator and condenser fan
F0	0	1	----	0	Evaporator fan activity during the blocking phase 0 = parallel function with the compressor

					1 = continuous function
F1	0	1	----	0	Evaporator fan activity during the conservation, refrigeration and precooling phases 0 = parallel function with the compressor 1 = continuous function
F2	0	1	----	0	Evaporator fan activity during the re-awakening phase 0 = parallel function with the main loads 1 = continuous function
F3	0	1	----	0	Evaporator fan activity during the proofing phase 0 = parallel function with the main loads 1 = continuous function
F4	0	1	----	0	Evaporator fan activity during the baking delay phase 0 = parallel function with the main loads 1 = continuous function
F5	0	1	----	0	Evaporator fan activity during the heating phase 0 = parallel function with the main loads 1 = continuous function
F10	0	100	%	100	Fan speed during the precooling phase
F11	0	100	%	100	Fan speed during the dehumidification phase
F12	0	15	min	2	Fan stop after the drip phase
F13	0	250	s	0	Evaporator fan switch-off delay from main load switch-off
F14	1	600	s	0	Evaporator fan cycle time, if set at 0, cyclical fan switch-on will be deactivated
F15	1	600	s	0	Evaporator fan switch-on time within the F14 cycle time
F16	0	99	°C	20	Condenser temperature above which the condenser fan is switched on, also with the compressor off
F17	0	240	s	5	Condenser fan switch-off delay from compressor switch-off (only applies if the condenser probe is disabled)
F18	0	240	s	15	Evaporator fan switch-on delay from when the door is closed, or the door switch input is deactivated.
F19	0	100	%	20	Minimum evaporator fan speed that can be set
F20	0	100	%	100	Maximum evaporator fan speed that can be set
F21	0	100	%	75	Evaporator fan start-up speed
F22	1	10	s	5	Start-up time when the evaporator fan is switched on
F23	0	100	%	35	Evaporator fan min. speed calibration value
F24	0	100	%	65	Evaporator fan max. speed calibration value
F25	-50	99	°C	1	Evaporator temperature below which the evaporator fan is activated for the blocking, conservation and manual refrigeration phases
<b>Par.</b>	<b>Min.</b>	<b>Max.</b>	<b>Unit</b>	<b>Default</b>	<b>Digital inputs</b>
i0	0	2	----	2	Effect caused by the door opening, or when the door switch input is activated. 0 = no effect 1 = The compressor, evaporator fan and heaters are switched off, the cabinet light is switched on 2 = The evaporator fan and heaters are switched off, the cabinet

					light is switched on
i1	0	1	----	1	Door switch input contact type 0 = normally open (input active with contact closed) 1 = normally closed (input active with contact open)
i2	-1	120	min	5	Door open alarm signal delay -1 = alarm not signalled
i3	0	1	----	1	Effect caused by activation of the high pressure input 0 = no effect 1 = The compressor and evaporator fan are switched off, the condenser fan is switched on
i4	0	1	----	0	High pressure input contact type 0 = normally open (input active with contact closed) 1 = normally closed (input active with contact open)
i5	-1	240	s	5	High pressure alarm signal delay -1 = alarm not signalled
i6	0	3	----	2	Effect caused by activation of the low pressure input 0 = no effect 1 = <u>ALARM</u> The compressor and evaporator fan are switched off 2 = <u>PUMP-DOWN AND ALARM MANAGEMENT</u> While the compressor is being switched off the digital input will act to switch off the compressor output to end the pump-down phase. During the activation phases of the refrigeration plant the digital input will act to switch off the compressor and evaporator fan. 3 = <u>COMPRESSOR THERMAL SWITCH ALARM</u> Compressor is switched off
i7	0	1	----	0	Low pressure input contact type 0 = normally open (input active with contact closed) 1 = normally closed (input active with contact open)
i8	-1	240	s	10	Low pressure alarm signal delay -1 = alarm not signalled
i9	0	240	s	40	Re-arm time for the low pressure switch when the compressor is switched on (only if i6 = 2)
i10	0	1	----	1	Thermal switch input contact type 0 = normally open (input active with contact closed) 1 = normally closed (input active with contact open)
i11	-1	240	s	5	Thermal switch alarm signal delay -1 = alarm not signalled
<b>Par.</b>	<b>Min.</b>	<b>Max.</b>	<b>Unit</b>	<b>Default</b>	<b>Digital outputs</b>
u1	0	2	----	0	Load managed by output K8 0 = Pump down valve (with this setting parameter u2 is relevant) 1 = Evaporator fan (in which case the output will repeat in ON/OFF mode the status of the PWM output for the evaporator fan) 2 = dehumidifier/extractor fan (with this setting parameters rU5 and rU6 are relevant)
u2	0	240	s	90	If i6 = 0 or 1: Compressor deactivation delay from pump-down valve switch-off (pump down being switched off, only for u1 = 0) If i6 = 2:

					Maximum pump-down duration in compressor switch-off mode without activating the low pressure input, causing the compressor to switch off and the pump-down alarm to sound 0 = No alarm signal
u3	0	1	----	0	Load managed by output K4 0 = dehumidifier/extractor fan (with this setting parameters rU5 and rU6 are relevant) 1 = Condenser fan (with this setting parameters F16 and F17 are relevant) With u3 = 1 dehumidification will be managed automatically by activation of the refrigeration plant
<b>Par.</b>	<b>Min.</b>	<b>Max.</b>	<b>Unit</b>	<b>Default</b>	<b>Serial communication (serial port type RS-485 with MODBUS communication protocol)</b>
L1	1	240	min	5	Internal data sampling time
LA	1	247	----	247	Device address
Lb	0	3	----	2	Baud rate 0 = 2,400 baud 1 = 4,800 baud 2 = 9,600 baud 3 = 19,200 baud
LP	0	2	----	2	Parity 0 = none 1 = odd 2 = even
PA1	426	-99	999	----	EPoCA level 1 password
PA2	824	-99	999	----	EPoCA level 2 password
bLE	1	0	99	----	Serial port connectivity configuration 0 = free 1 = forced for EPoCA 2-99 = EPoCA local network address
<b>Par.</b>	<b>Min.</b>	<b>Max.</b>	<b>Unit</b>	<b>Default</b>	<b>Other</b>
E8	0	240	min	1	Inactivity period for enabling screen-saver 0 = not enabled
E9	0	1	----	1	Display EVCO splash screen at power-on 0 = Neutral screen 1 = EVCO splash screen
E11	0	120	s	10	Duration of buzzer at cycle end and on reaching the precooling setpoint
E12	0	2	----	0	Type of humidifier 0 = humidifier with steamer 1 = humidifier with serial control (EASYSYSTEM) 2 = humidifier with instant generation
E13	0	240	min		Duration of "cycle completed" display 0 = not enabled
E14	----	----	----	----	unused
E15	0	1	----	0	Cookbook lock

---

					0 = disabled
					1 = enabled

## 15 ACCESSORIES

### 15.1 Safety transformer (ECTSFD004)

The transformer can power the Vcolor 618 L user interface.



### 15.2 Non-optoisolated RS-485/USB serial interface (EVIF20SUXI)

Makes it possible to connect to the Parameters Manager setup software system.



### 15.3 USB plug for panel installation (081200002)

This plug grants access to the controller's USB communications port. To connect the port to the plug, connecting cable 0810500018 or 0810500020 must be used (to be ordered separately).



### 15.4 Connecting cables (0810500018/0810500020)

Make it possible to connect via a USB to a personal computer or other device with a USB port. Length: 2 m (6.56 ft) for 0810500018, 0.5 m (1.64 ft) for 0810500020.



### 15.5 Phase cutting speed regulator (EVDFAN1)

Makes it possible to regulate a single-phase fan speed with a PWM command signal. The maximum operating current is 5 A.





### 15.6 USB flash drive (EVUSB4096M)

Makes possible configuration upload and download. 4GB of memory.



### 15.7 Graphic synoptic device (EVC25T00X7XXX04)

The graphic synoptic device displays the process status instantly and intuitively.



### 15.8 Polyester overlay (0041600281)

Use of the polyester overlay makes it possible to wash down the front of the unit where the graphic synoptic device is installed.

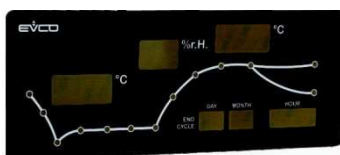

### 15.9 EVlink Wi-Fi RS-485 module (EVIF25SWX)

Through the RS-485 communications port, the module provides the controller with Wi-Fi connectivity which enables remote management and monitoring from the Internet using the EPoCA cloud system.



## 16 TECHNICAL SPECIFICATIONS

### 16.1 Technical specifications

<b>Purpose of the control device</b>	Function controller		
<b>Construction of the control device</b>	Built-in electronic device		
<b>Container</b>	user interface		control module
	Open frame board behind glass.		Open frame board
<b>Category of heat and fire resistance</b>	D		
<b>Measurements</b>	user interface M	user interface L	control module
	Flush installation: 118,0 x 166,0 x 35,0 mm (4,645 x 6,535 x 1,377 in; L x H x D).  Semi-recessed installation: 97,1 x 145,1 x 32,0 mm (3.822 x 5.712 x 1.259 in; L x H x D).	Flush installation: 156,0 x 216,0 x 50,0 mm (6,141 x 8,503 x 1,968 in; L x H x D).  Semi-recessed installation: 131,9 x 192,9 x 47,0 mm (5.192 x 7.594 x 1.850 in; L x H x D).	166.0 x 116.0 x 44.0 mm (6.535 x 4.566 x 1.732 in; L x H x D).
<b>Mounting methods for the control device</b>	user interface		control module
	flush with the panel from behind with threaded studs (not provided) to hold it in place or semi-recessed from the front of the panel using the spring clips		On a flat surface with spacers.
<b>Degree of protection</b>	user interface		control module
	IP65 (front)		IP00
<b>Connection method</b>	user interface		control module
	Plug-in screw terminal blocks for wires up to 1.5 mm <sup>2</sup> , type A female USB connector (USB port).		Plug-in screw terminal blocks for wires up to 2.5 mm <sup>2</sup>
<b>Connection method</b>	Maximum permitted length for connection cables		
	<ul style="list-style-type: none"> <li>- User interface-control module connection: 10 m (32.8 ft)</li> <li>- Power supply: 10 m (32.8 ft)</li> <li>- Analogue inputs: 10 m (32.8 ft)</li> <li>- Digital inputs: 10 m (32.8 ft)</li> <li>- Analogue outputs: 10 m (32.8 ft)</li> <li>- Digital outputs: 100 m (328 ft)</li> <li>- RS-485 MODBUS port: 1,000 m (3,280 ft)</li> <li>- USB port: 1 m (3.28 ft).</li> </ul>		
<b>Operating temperature</b>	From 0 to 55 °C (from 32 to 131 °F)		
<b>Storage temperature</b>	From -10 to 70 °C (from 14 to 158 °F).		

<b>Operating humidity</b>	Relative humidity without condensate from 10 to 90%	
<b>Pollution status of the control device</b>	2.	
<b>Environmental standards</b>	<ul style="list-style-type: none"> <li>- RoHS 2011/65/EC</li> <li>- WEEE 2012/19/EU</li> <li>- REACH (EC) Regulation 1907/2006.</li> </ul>	
<b>EMC standards</b>	<ul style="list-style-type: none"> <li>- EN 60730-1</li> <li>- IEC 60730-1.</li> </ul>	
<b>Power supply</b>	user interface	control module
	Vcolor 618 M: powered by the control module. Vcolor 618 L: 12 VAC 20 VA.	115... 230 VAC ( $\pm 15\%$ ), 50 / 60 Hz ( $\pm 3$ Hz), 10 VA max.
<b>Rated impulse-withstand voltage</b>	4 KV	
<b>Over-voltage category</b>	III.	
<b>Software class and structure</b>	A.	
<b>Clock</b>	Built-in (with secondary lithium battery).	
	Clock drift: $\leq 60$ s/month at 25 °C (77 °F)	
	Clock battery autonomy in the absence of a power supply: > 6 months at 25 °C (77 °F)	
	Clock battery charging time: 24 h (the battery is charged by the power supply of the device).	
<b>Analogue inputs</b>	4 inputs, 3 of which PTC/NTC inputs (cabinet probe, evaporator probe and condenser probe) and 1 4-20 mA input (humidity probe).	
	<i>PTC type analogue inputs</i>	
	Sensor type:	KTY 81-121 (990 Ohm @ 25 °C, 77 °F).
	Measurement field:	from -50 to 150 °C (from -58 to 302 °F).
Resolution:	1 °C (1 °F).	
Protection:	none.	
<i>NTC type analogue inputs</i>		
Sensor type:	B3435 (10 K $\Omega$ Ohm @ 25 °C, 77 °F).	
Measurement field:	from -40 to 105 °C (from -40 to 221 °F)	
Resolution:	1 °C (1 °F).	
Protection:	none.	
<i>4-20 mA type analogue inputs</i>		
Measurement field:	can be configured	
Protection:	none.	
<b>Digital inputs</b>	4, dry contact (door switch, compressor thermal switch, low and high pressure switch).	

	<p><i>Dry contact</i></p> <p>Contact type: 5 VDC, 2 mA.</p> <p>Power supply: none</p>
<b>Analogue outputs</b>	1 for PWM signal (for phase cutting speed regulator for single-phase EVDFAN1 fans).
<b>Digital outputs</b>	<p>8 outputs (electro-mechanical relays):</p> <ul style="list-style-type: none"> <li>- 1 16 A res. @ 250 VAC type SPST (K1) output for managing the compressor</li> <li>- 1 8 A res. @ 250 VAC type SPDT (K5) output for managing defrost</li> <li>- 1 8 A res. @ 250 VAC type SPST (K3) output for managing the humidifier</li> <li>- 1 16 A res. @ 250 VAC type SPDT (K6) output for managing the heaters</li> <li>- 1 8 A res. @ 250 VAC type SPST (K7) output for managing the steam generator</li> <li>- 1 8 A res. @ 250 VAC type SPST (K2) output for managing the cabinet light*</li> <li>- 1 8 A res. @ 250 VAC type SPST (K4) output that can be configured for managing the dehumidifier (default) or the condenser fan</li> <li>- 1 8 A res. @ 250 VAC type SPST (K8) output that can be configured for managing the pump down valve (default) or the evaporator fan</li> </ul> <p>* The relays do not manage LED and fluorescent lamps</p>
<b>Displays</b>	5 or 7-inch TFT touch-screen graphic display, 16K colours, 800 x 480 pixel resolution. The presence of point defects on the display falls within the tolerance limits as provided by applicable standards.
<b>Type 1 or Type 2 Actions</b>	Type 1.
<b>Additional features of Type 1 or Type 2 actions</b>	C.
<b>Communications ports</b>	<p>2 ports:</p> <ul style="list-style-type: none"> <li>- 1 RS-485 MODBUS port</li> <li>- 1 USB port</li> </ul>
<b>Warning and alarm buzzer</b>	Built-in

**Vcolor 618**

Controller for retarding-proofing cabinets and rooms, with 5 or 7-inch colour TFT touch-screen graphic display, in split version

Installer manual ver. 4.0

PB - 19/21

Code 144VC618E404

This document and the solutions contained therein are the intellectual property of EVCO and thus protected by the Italian Intellectual Property Rights Code (CPI). EVCO imposes an absolute ban on the full or partial reproduction and disclosure of the content other than with the express approval of EVCO. The customer (manufacturer, installer or end-user) assumes all responsibility for the configuration of the device. EVCO accepts no liability for any possible errors in this document and reserves the right to make any changes, at any time without prejudice to the essential functional and safety features of the equipment.



EVCO S.p.A.  
Via Feltre 81, 32036 Sedico Belluno ITALY  
Tel. 0437/8422 | Fax 0437/83648  
info@evco.it | www.evco.it