

# **NV2195CK COMPRESSOR**

---

## **TECHNICAL SPECIFICATION**



**HUANGSHI DONPER COMPRESSOR CO., LTD.**

**2026.04**

# INDEX

	<b>Page</b>
1. Compressor Type .....	2
2. Performance Data .....	2
3. Running Condition .....	2
4. Compressor Mechanical Information .....	3
5. Compressor Shape .....	3
6. Wiring Diagram .....	4
7. Starting relay and overload protector .....	5
8. Capacitor .....	6
9. Delivery State .....	6
10. Package、Storage and Transportation .....	7
11. Technical Items .....	7

### 1. Compressor Type

Compressor model	NV2195CK
Rated voltage/frequency	220-240V~50Hz
Refrigerant	R404A
Application	Low/Middle back pressure (L/MBP)
Cooling method	Fan Cooling
Start torque	High starting torque (HST)
Control device	Capillary tube
Motor type	CSR
Running capacitor	25 μ F
Starting capacitor	100 μ F

### 2. Performance Data

Displacement	Net Wt.	Oil Charge	Cooling Capacity(≥95%)										COP(≥95%)		
			ASHRAE										CECOM AF	ASHR AE	CECO MAF
			-35	-30	-25	-23.3	-20	-15	-10	-5	0	-25	-23.3	-25	
cm <sup>3</sup>	kg	ml	w	w	w	w	w	w	w	w	w	w	w/w	w/w	
27.8	18.5±0.4	450±10	525	729	968	1100	1324	1732	2127	2641	3211	788	1.25	0.97	

Note: These datas come from the test without a PTC relay

#### Testing condition:

Test conditions	LBP	
	ASHRAE	CECOMAF
Evaporating Temp.	-23.3°C	-25°C
Ambient Temp.	+32.2°C	+32°C
Condensing Temp.	+54.4°C	+55°C
Suction Temp.	+32.2°C	+32°C
Subcooling Temp.	+32.2°C	+55°C

### 3. Running Condition

Ambient temp.	0~43°C
Evaporating temp.	-35~-15°C
Voltage range	187~254V
Max. condensing temp.	65°C
Max. winding temp.	130°C
Max. shell temp.	110°C
Max. discharge temp.	130°C
Start voltage	187V [1.1/1.1MPa(abs)]
Shell min. resistance to pressure	35bar

### 4. Compressor Mechanical Information

Oil type	POE oil
Viscosity	28.8~35.2 mm <sup>2</sup> /s(40°C)
Oil charged	450±10ml
Diameter of suction tube (I.D.)	Φ 9.6±0.1mm
Diameter of discharge tube(I.D.)	Φ 6.2±0.1mm
Diameter of process tube (I.D.)	Φ 9.6±0.1mm
Material of suction tube, process tube and discharge tube	Copper tube
Compressor noise	≤66dB(A)
Vibration	≤6.0m/s <sup>2</sup>
Protecting gas	Dry com. air (Dew point-60°C)

### 5. Compressor Shape

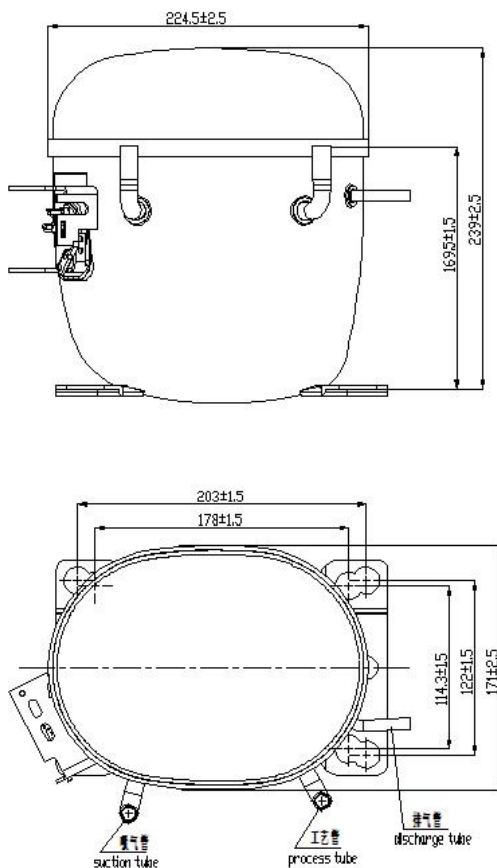

Caution : Suction tube and process tube can be exchanged.

Unmarked tolerance: ± 5mm

Unmarked Angle: ± 10°

## 6. Wiring Diagram

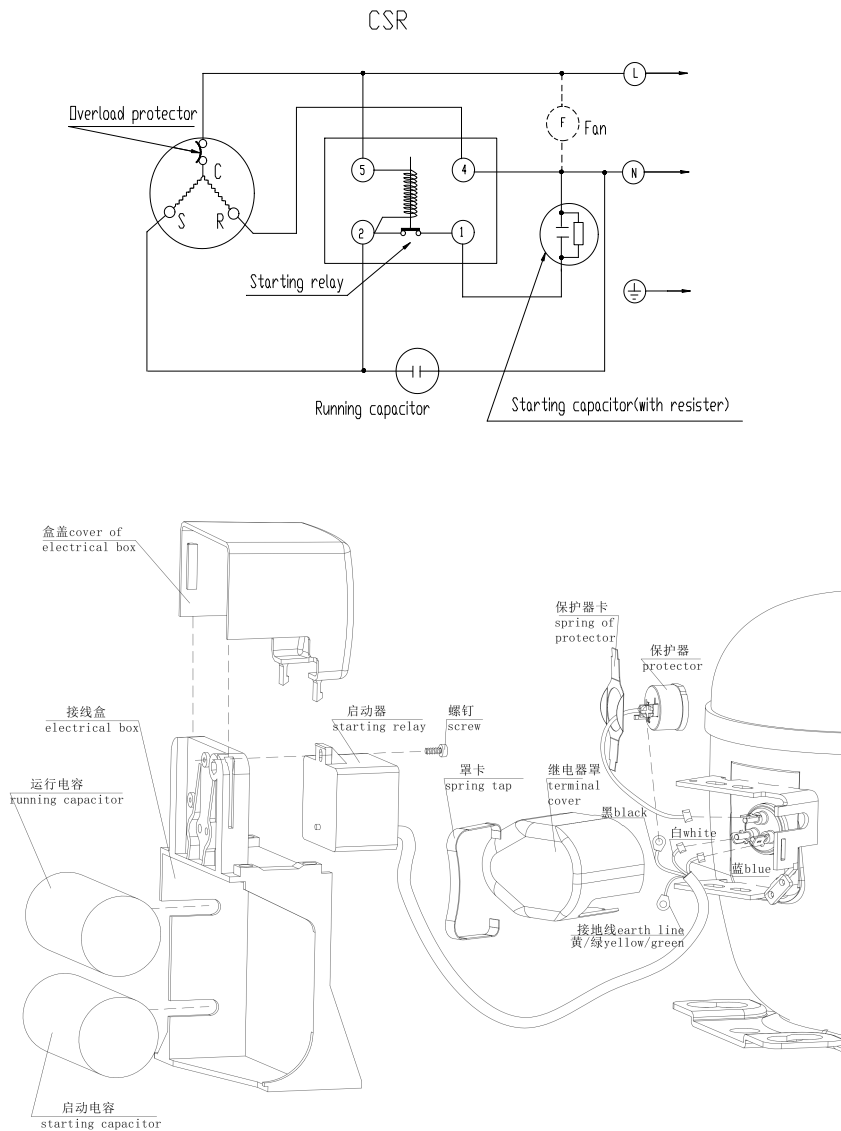

Note: Each of the starting relay、the overload protector、 the capacitor 、the spring for overload protector and the cover is separately provided by our company.

**7. Starting relay and overload protector**

**7.1 Starting relay**

Model	RVA 4I3C	DYS 4I3C
Supplier	ELSING (SUZHOU) ELECTRICAL CONTROLS CO.,LTD.	Lanxi City Yueqiang Electric Co., Ltd.
Max pull-in voltage V	242~272	
Min release voltage V	60~121	

Flammability: Anti-flammability

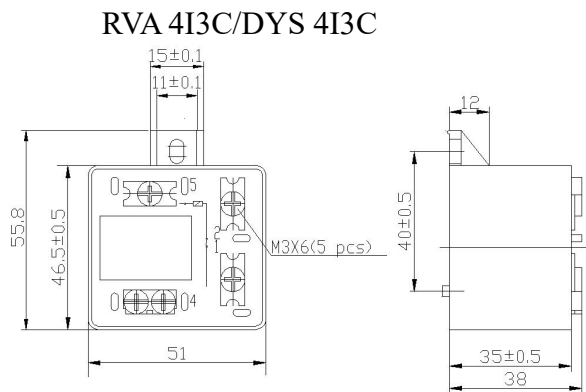

Unmarked tolerance: ± 1mm

**7.2 Overload protector**

Model	T1130	DRB-B265-120
Supplier	ELSING (SUZHOU) ELECTRICAL CONTROLS CO.,LTD	Hangzhou Star shuaier Electric Appliance Co.,LTD
Max.T.C Amp.(25°C) A	26.5	
Trip time S	6~16	
Reset time S	10~80	
Open temp. ±5°C	120	
Close temp. ±9°C	61	

Flammability: Anti-flammability

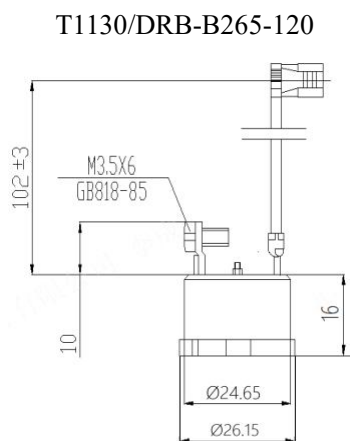

Unmarked tolerance: ± 1mm

**8. Capacitor**

Type	Starting capacitor	Running capacitor
Model            μF	100	25
Rated voltage    V.AC	330	450
Supplier and model	Huangshan Zhenzhou Electronic Technology Co., Ltd.	Anhui Feida Electrical Technology Co., Ltd.
	FUXIN JIEKEDA ELECTRONIC CO.LTD	Anhui Tongfeng Electronics Co.,Ltd.

**9. Delivery State**

No.	Name	Model	Quantity	CODE
1	Compressor	NV2195CK	1pcs	
2	Rubber plug	Φ8.2	1pcs	Installed on the compressor
		Φ11.5	2pcs	Installed on the compressor
3	Rubber grommet	Q79E-03	4pcs	
4	Starting relay	RVA 4I3C	1pcs	ELSING (SUZHOU) ELECTRICAL CONTROLS CO.,LTD.
		DYS 4I3C		Lanxi City Yueqiang ElectricCo., Ltd.
5	Overload protector	DRB-B265-120	1pcs	Hangzhou Star shuaier Electric Appliance Co.,LTD
		T1130		ELSING (SUZHOU) ELECTRICAL CONTROLS CO.,LTD.
6	Starting capacitor	100 μ F	1pcs	Huangshan Zhenzhou Electronic Technology Co., Ltd
				Fuxin Jiekeda Electronic Co.Ltd
7	Running capacitor	25 μ F	1pcs	Anhui Feida Electrical Technology Co., Ltd.
				Anhui Tongfeng Electronics Co.,Ltd.
8	Relaying cover	Q79E-09	1pcs	
9	Earth bolt	QET.1-24C	1pcs	
10	Sleeve	Φ 11.1×23	4pcs	
11	Spring cover holder	Q79E-08	1pcs	
12	Spring for overload protector	Q79E-11	1pcs	
13	Anchor bolt assembly	M6×30	4pcs	
14	Nut	M6	4pcs	

Notes:1. Except for special remakes, all electrical parts and equipment assembly are supplied separately, not installed on the compressor.

2.All electrical parts and equipment assembly according to “Delivery state” are all provided by our company.

**10. Package、 Storage and Transportation**

Package type	Unrecyclable
Quantity	45pcs/box
Transportation	By sea
Storage	Max. 2 layers
Cross Weight	Kg 863±18
Net Weight	Kg 833±18
Volume	m <sup>3</sup> 1.02
Dimension: length×width×height	cm 104×102×96
Main components	Wooden supporter、 upper wooden cover、 foam divider、 plastic sheet、 cardboard cover、 wrapping
Movement	Keep the compressor in normal or vertical position
Trans. test requirement	No allowable compressor’s damage and performance loss.

**11. Technical Items**

- (1)、 Don’t take off the rubber plugs before using and installing compressor to prevent dust and moisture.
- (2)、 Don’t turn down or incline the compressor during storage, transportation or installation and avoid vibration and shock.
- (3)、 The compressor must be kept horizontally during running, the inclination angle must be less than 5°.
- (4)、 A special polyester oil is charged in the R404A compressor and the charging volume has been optimized by DONPER. Don’t pour out or add any refrigerant oil.
- (5)、 The interval of compressor operation must be more than 4 minutes in order to obtain a pressure balance in the systems.
- (6)、 Don’t start or run in the case of vacuum or charge high voltage in the compressor. The compressor cannot be used to vacuumize the refrigeration system.
- (7)、 The design of refrigeration system must be suitable to insure the oil could flow back to compressor.
- (8)、 The maximum ambient temperature of the compressor operation is 43°C. When continuously operating under the maximum ambient temperature 43°C, the condensing pressure and the peak pressure should not exceed as showing in the following table.

Refrigerant	R404A
Max. condensing pressure	2.68MPa
Peak	3.0 MPa

- (9)、 Widen the evaporating Temp. range of the compressor should be approved by DONPER.

- (10)、 Compressor should be stored in a dry place.
- (11)、 Compressor accessories (eg: starting relay, overload protector etc.) are put in the accessories box instead of fixing on the compressor.
- (12)、 The stocking period must be less than 6 months after the date of production. If longer, you have to check whether the filled gas is sufficient. Replenishment must be done if necessary.
- (13)、 It's necessary to keep the compressor without rubber plug as short time as possible (max time 10 min).
- (14)、 R404A systems require a filter with drying agent which suitable for R404A refrigerant
- (15)、 The vacuum pump and the charging system must only be dedicated to R404A.
- (16)、 The refrigeration system should minimize the content of chlorine and moisture, and must be free of paraffin and silicon oil.
- (17)、 The organic substance non-compatible with R404A cannot be used in the refrigeration system.